

# Overrunning, Indexing, Backstopping Clutches



 **Formsprag**<sup>®</sup>  
Clutch

*An Altra Industrial Motion Company*



## Formsprag Clutch

For over 50 years, Formsprag Clutch has been the recognized leader in designing, manufacturing, and delivering dependable long-lived overrunning clutches for a wide spectrum of industrial applications including mining, aerospace & defense, packaging, food processing, and material handling.

By offering the broadest range of both sprag and ramp & roller type overrunning clutches and backstops available globally, Formsprag Clutch, together with our sister company Stieber Clutch in Germany, is the world's leading authority for solving application challenges requiring overrunning clutches.



[www.formsprag.com](http://www.formsprag.com)

Check out the Formsprag eCatalog, an online product configurator at [www.formsprag.com](http://www.formsprag.com). Just input your application's requirements using the drop down menus to identify performance criteria.

The right product will power its way up to the top.

- Download 2D and 3D CAD formats and dimensional line drawings.
- Submit an online RFQ to the local distributor of your choice.

## Altra Industrial Motion

Altra is a leading multinational designer, producer and marketer of a wide range of mechanical power transmission products. We sell our products in over 70 countries throughout the world.

Our products are frequently used in critical applications, such as fail-safe brakes for elevators, wheelchairs and forklifts as well as in a wide range of high-volume manufacturing processes, where reliability and accuracy are important for both avoiding costly downtime and enhancing the overall efficiency of manufacturing operations.

Altra products are marketed under a variety of well recognized and established manufacturing brand names including Warner Electric, Boston Gear, TB Wood's, and Formsprag Clutch.

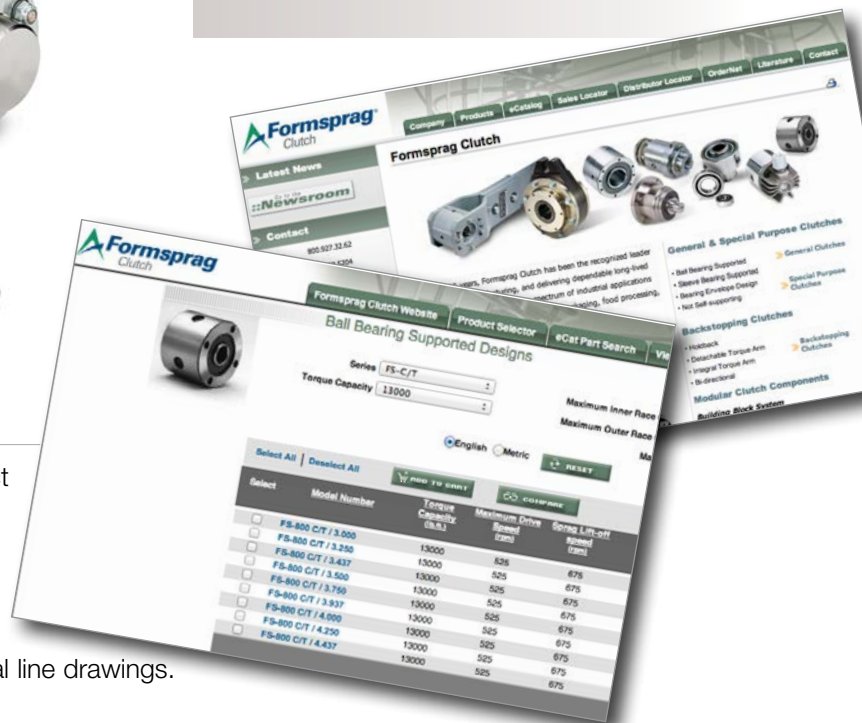

Formsprag's Quality Management System is certified to ISO 9001:2008 and AS 9100 Rev.C.



**A wide range of styles and sizes to choose from...**

## General & Special Purpose Clutches



- Ball Bearing Supported
- Sleeve Bearing Supported
- Bearing Envelope Design
- Not Self-supporting

## Backstopping Clutches



- Holdback
- Detachable Torque Arm
- Integral Torque Arm
- Bi-directional

## Modular Clutch Components



- Building Block System**
- Clutches
  - Flanges
  - Covers

## Clutch Couplings



- Overrunning Clutches
- Couplings

While the wide range of sizes and capabilities covered by this catalog will cover substantially all industrial needs, it is sometimes necessary to design and manufacture clutches to meet specialized requirements.

Formsprag's and Stieber's years of research and development in this specialized field are at your service to help solve all special overrunning clutch applications. In many cases a standard clutch can be adapted to a special use. You can be sure of a clutch that will meet your exact requirements simply by supplying complete application data to your local Altra Industrial Motion sales representative.

Clutch Functions and Applications .....	2
Overrunning Clutch Designs .....	4
Principles of Operation .....	6
Selection .....	8
Models: .....	14
AL/ALM .....	92
AL..F2D2, AL..F4D2; ALM..F2D2, ALM..F4D2 .....	94
ALP..F7D7, ALPM..F7D7 .....	96
AL..KEED2, ALM..KEED2 .....	110
AS .....	34
ASK .....	30
ASNU .....	36
Building Block System .....	90
CDU .....	54
CSK, CSK..2RS .....	26
CSK..P, CSK..PP .....	28
DC .....	40
FHB .....	84
FRB .....	18
FS 02, 04, 05 .....	22
FS 20 and 50 .....	38
FS 100, 200 and 300 .....	46
FS/FSO/HPI .....	16
FSA .....	20
FSD/HBG .....	52
FSO/HPI .....	14
FSR .....	24
FW/FWW .....	114
GFK .....	32
GFR/GFRN .....	98
GFR..F1F2, GFR..F2F7, GFRN..F5F6 .....	100
GFR..F2F3, GFR..F3F4 .....	102
HFB/VFB .....	88
HPO .....	48
HSB .....	64
LCB .....	86
LLH .....	68, 74
RIZ/RINZ .....	104
RIZ, RINZ..G1G2, G2G7, G5G5 .....	106
RIZ..ELG2 .....	112
RIZ..G2G3, G3G4 .....	108
RL .....	58
RSCI .....	42
RSBW .....	62
SB/SBI .....	50
Accessories .....	122
Stieber Interchange Chart .....	127
Cross-Reference Part Numbers .....	127
Engineering Data .....	128
Application Data Form .....	135
Conversion Factors .....	136
Rebuild and Overhaul Service .....	137



# Clutch Functions and Applications

All Formsprag/Stieber clutches described in this catalog are “overrunning” clutches, i.e., they will drive in one direction but overrun (freewheel) in the other direction. The preparation of a catalog such as this can be undertaken only by a company having very broad experience in all aspects of the use and application of overrunning clutches.

Formsprag/Stieber is such a company, and the information given in this catalog

is based on the accumulation of many years of experience in the design, construction and application of overrunning clutches. In physical appearance, the Formsprag/Stieber catalog overrunning clutches are all very much alike. However, different types of applications will involve differing load characteristics and will call for variations in the technical details of clutch construction. For this reason the clutches

are divided into three basic types of applications for which they are intended.

The three basic applications are:

- **Overrunning**
- **Indexing**
- **Holdbacks or Backstops**

These three categories are described in greater detail under those headings in this catalog.

## Overrunning clutch

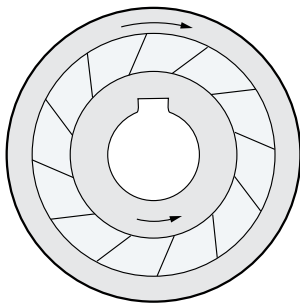

This class of applications is typified by standby and compound drives. For example, a steam turbine and a standby electric motor may be connected to a single driven shaft through overrunning clutches. The shaft can then be driven by either the turbine or the motor or both with no further modification of the installation. The turbine drive clutch automatically engages when the turbine starts to drive, but automatically overruns when the load is transferred to the electric motor.

### Considerations

- Type of motor
- Max starting torque
- Internal combustion engines, please consult Formsprag
- Nominal driving torque
- Range of driving speed
- Inertia ( $WR^2$ ) of the driven masses
- Range of overrunning speed
- Number of starts during service life
- Shaft diameter

### Applications

- Dual motor/engine drives
- Conveyor belts
- Creep and starter drives
- Disengagement of centrifugal masses

## Indexing clutch

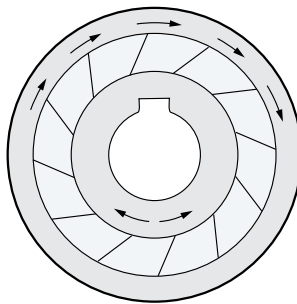

In this type of application, reciprocating motion applied to the driving race is transformed into intermittent motion in only one direction at the driven race. For example, if a pinion is connected to the driving race, a rack meshing with the pinion can give reciprocating motion to the driving race. The clutch will then advance or “index” the work (driven race) on each forward stroke of the rack, but will not return or back-up on the return stroke of the rack.

### Considerations

- Number of cycles/min
- Index angle
- Nominal torque
- Inertia ( $WR^2$ ) of the driven masses
- Accelerations of the driving member
- Number of indexes during service life
- Shaft diameter

### Applications

- Metal stamping
- Pressworking
- Packing machines
- Indexing tables
- Assembling machines
- Printing machines

## Backstopping clutch

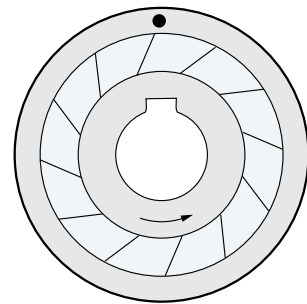

In backstopping or holdback\* applications, one race is always fixed to a stationary ground member. The function of the clutch is to permit rotation of the mechanism, connected to the other race, in one direction only, and to prevent any rotation in the reverse direction at all times. Although the clutch normally overruns most of the time, it is referred to as a holdback or backstop in conveyors, gear reducers and similar equipment because its function is to prevent reverse rotation.

*\*“Holdback” is a name given to a backstop clutch when mounted on an inclined conveyor head shaft.*

### Considerations

- Motor breakdown torque
- Maximum dynamic reverse torque due to elasticity of the locked parts: elastic belts, shafts of more than 9 feet (3 meters) long
- Range of overrunning speed
- Number of torque applications during service life
- Shaft diameter

### Applications

- Inclined conveyors
- Escalators
- Pumps
- Gear drives
- Fans

# Clutch Functions and Applications

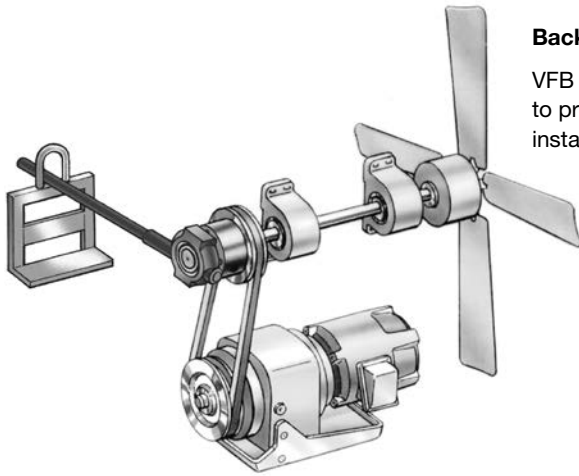

## Backstopping

VFB & HFB models provide automatic backstopping for fans to prevent wind milling when the fan is turned off, actuates instantaneously to prevent any reverse rotation.

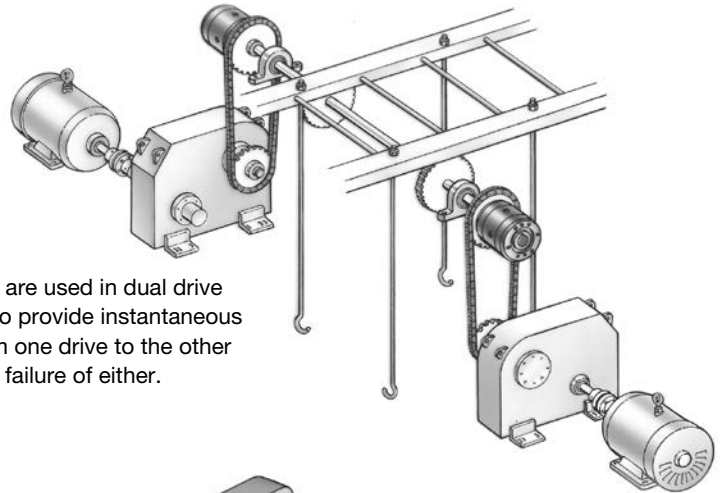

## Dual Drive

FSO clutches are used in dual drive applications to provide instantaneous clutching from one drive to the other in case of the failure of either.

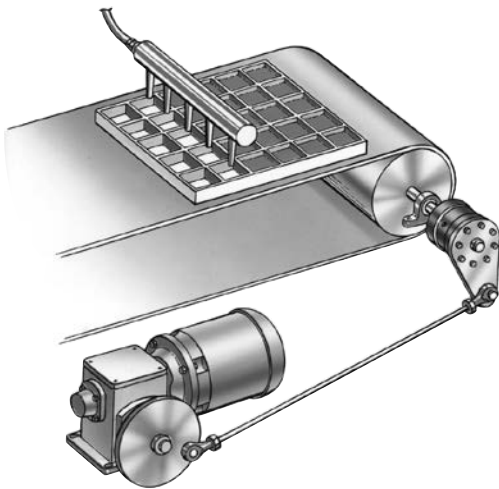

## Indexing

Indexing clutches are used to convert reciprocating linear motion to incremental rotary motion for conveyor or material feed applications.

**Clutch Models:** HPI, AL

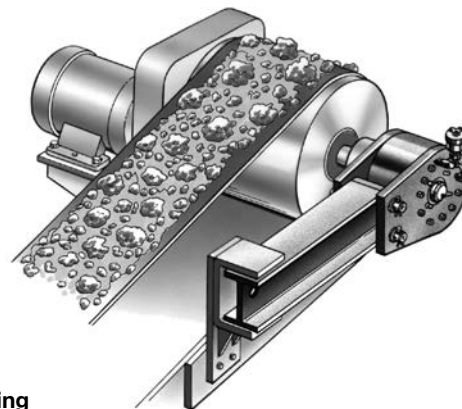

## Backstopping

The LLH Holdback clutch is used to backstop (prevent reverse rotation) the incline conveyor in a material handling application.

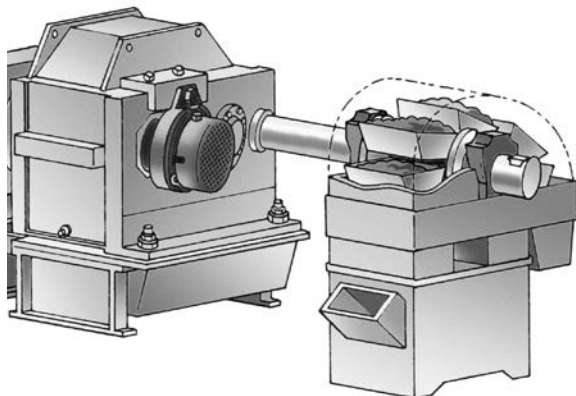

## Backstopping

FHB backstops are mounted on the double extended input shaft of gear reducers and provide instantaneous automatic backstopping to the drive system for typically inclined conveyors and bucket elevator applications.

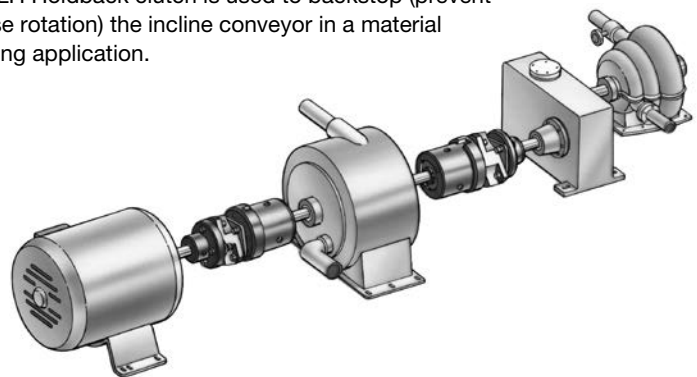

## Clutch-Couplings

Clutch Couplings are used for dual drive of a pump or fan, and when there is a need to connect inline shafts. The clutch coupling prevents backdriving of the other drive source when operating at motor speeds. Clutch couplings allow for the transition from one drive source to another without controls.

**Clutch Models:** FW, FWW, ALKMS, RIZEL,AL..KMSD2, RIZ..ELG2

# Overrunning Clutch Designs

## Ramp & Roller Overrunning Clutches

### Two Design Styles

Stieber overrunning clutches are available in two basic designs:

- Ramp & Roller
- Sprag

Overrunning clutch speed is a major determining factor in selecting the design best suited for each application. Ramp & roller clutches are used for applications with low-to-medium overrunning speeds and for indexing. Sprag clutches are the choice for applications with high overrunning speeds and for backstopping.

With each basic design there are several variations to choose from to meet specific application requirements. These variations include clutches with or without internal bearings, as well as a range of mounting flanges, covers and couplings.

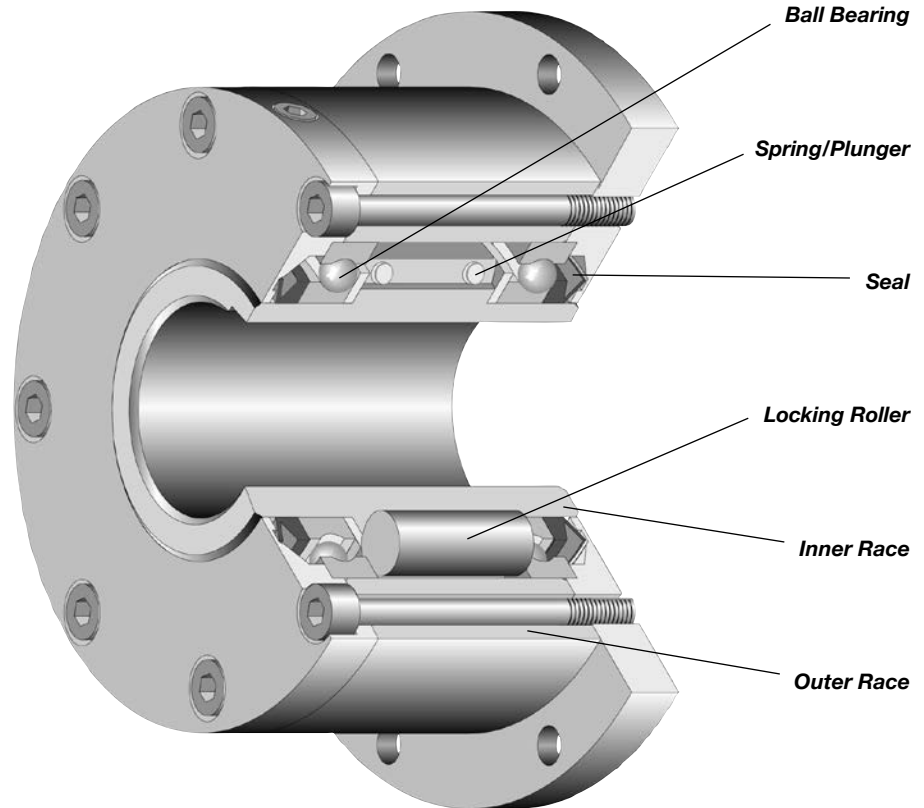

### Ramp & Roller Design

These rugged, reliable clutches consist of a cylindrical outer race and an inner race incorporating the ramps on which the rollers ride. The rollers are individually spring loaded to provide constant force between the rollers and both races.

This force ensures instantaneous lock-ups when switching from the overrunning mode to the driving mode.

This design is also quite versatile, as the clutch can be operated in all three modes: overrunning, indexing and backstopping. The outer race has greater overrunning speed capability than the inner race, making the unit ideal for use as an indexing clutch, with the outer race acting as the reciprocating member.

For increased accuracy in indexing applications, specify "V" type, with stronger energizing springs.

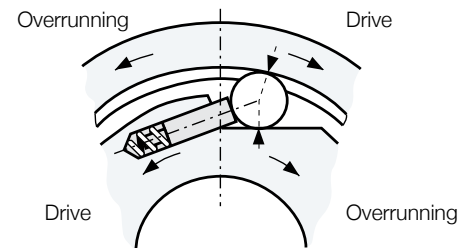
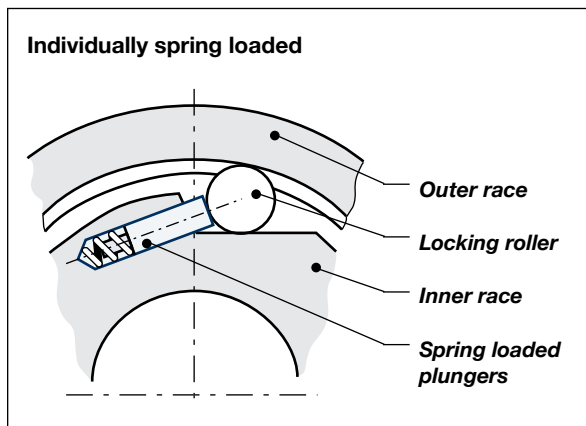

When the outer race is the driving member, this is the resultant race activity.

# Overrunning Clutch Designs

## Sprag Overrunning Clutches

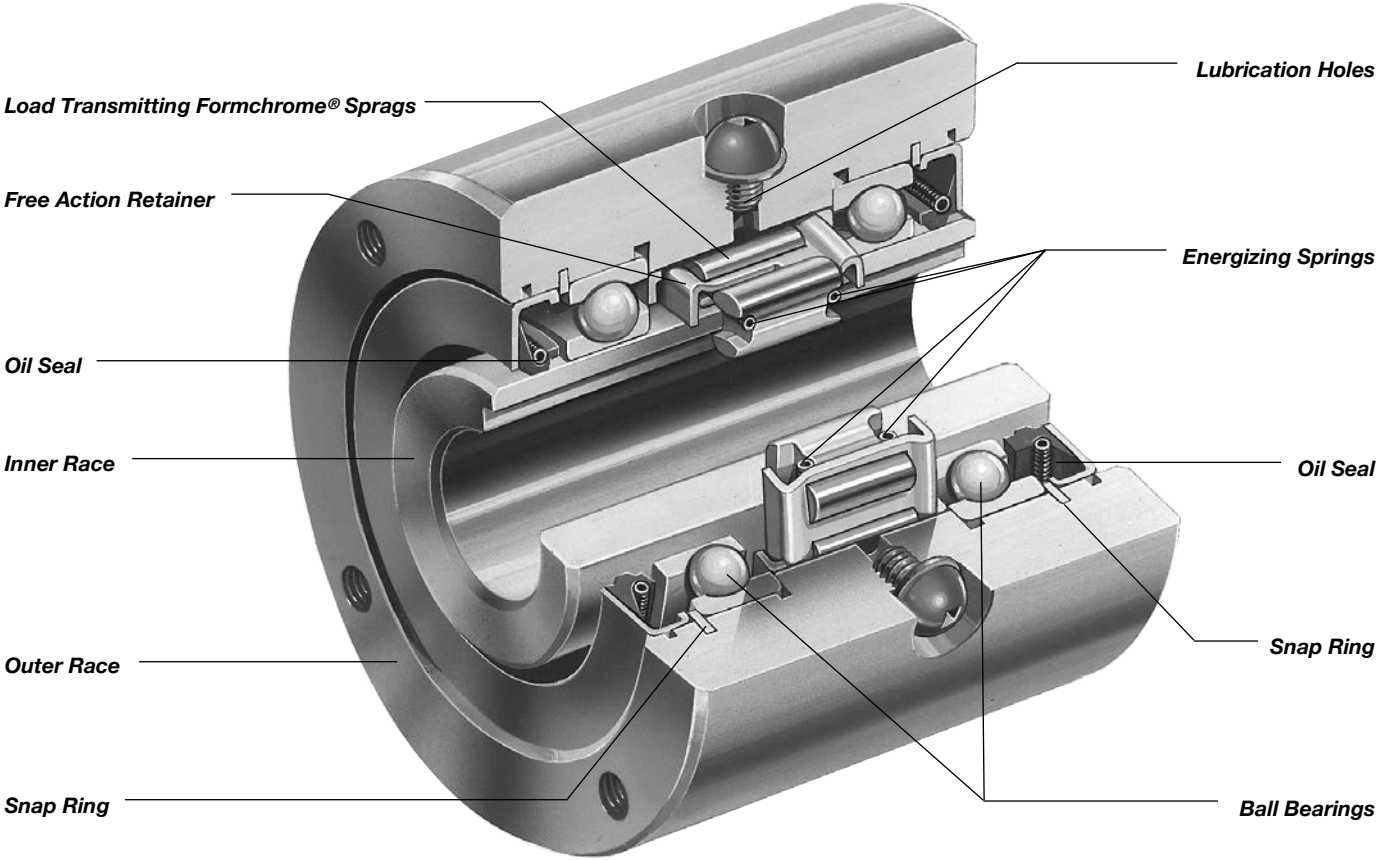

### Sprag Design

A sprag overrunning clutch consists of a cylindrical inner race and a cylindrical outer race surrounding it, with an annular space between the two races. A full complement of accurately formed sprags fills this annular space. Each sprag is essentially a strut placed between the races in such a way that it transmits power from one race to the other by a wedging action when either race is rotated in the driving direction. Rotation in the

other direction disengages the sprags and the clutch is free, or overruns. Either race may be the driven member or driving member.

If one race of the overrunning clutch is securely fixed to a grounded member, so that it cannot rotate, and the other race is free to turn, the free race will turn freely in one direction of rotation, but will be locked to the ground in the opposite direction.

In an overrunning clutch, the specific sprag shapes have been developed to meet most conceivable types of clutch applications. Since different types of overrunning applications involve different loading characteristics, different sprag shapes are used to provide the greatest possible life, torque capacity, and functional characteristics for the three basic types of overrunning clutch applications: overrunning, indexing, and backstopping.

### Various Sprag Designs

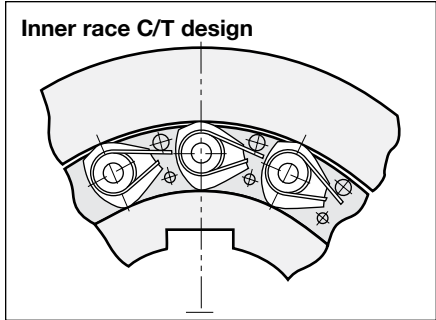
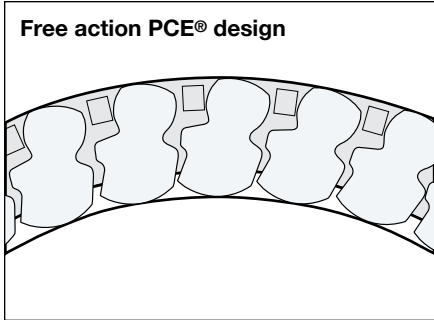
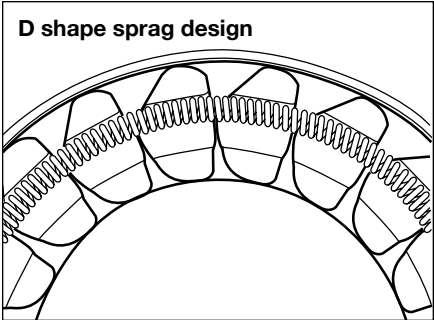

# Principles of Operation

## Ramp & Roller Design

Ramp & roller clutches consist essentially of an outer race with a cylindrical inside diameter, an inner race with ramps, and a set of rollers which are individually spring loaded to provide constant contact between the rollers and both races. This arrangement assures instant action at all running speeds and guarantees immediate driving capability whenever one of the two races rotates with respect to the other in the drive direction.

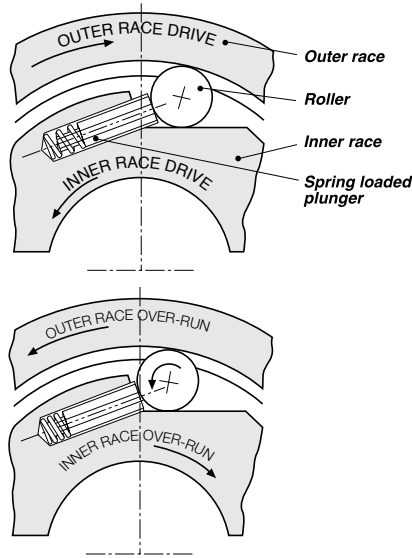

## Application

Clutches of this type can be used in all types of overrunning, backstopping and indexing applications.

**When used as an overrunning clutch** the ramp & roller clutch should be mounted in such a way that the outer race is the overrunning member. This is especially important with higher overrunning speeds. In applications where the inner race overruns, the centrifugal force on the rollers results in lower overrunning speed limits.

**When used as a backstop** a ramp & roller clutch with rotating inner race is especially suited at lower speeds. If the RPM is higher than the RPM recommended in the tables, we suggest using a sprag type clutch.

**When used as an indexing clutch** the outer race should always be the oscillating member and the inner race should be the driven member. Otherwise, the inertia of the rollers and springs will lead to inaccuracies, especially at high index

frequencies. The use of thinner lubricating oil and stronger springs will provide higher indexing accuracy and can be supplied upon request.

## Sprag Design

This sprag-type design overrunning clutch generally consists of an inner race, an outer race, a set of sprags, a sprag retainer, energizing springs, and bearings.

The wedging of the sprags between the races transmits power from one race to the other. The sprags have a greater diagonal dimension across one set of corners than across the other (see Figure 1). The wedging action occurs when the relative rotation of the inner and outer races tends to force the sprag to a more upright position where the cross-section is greater.

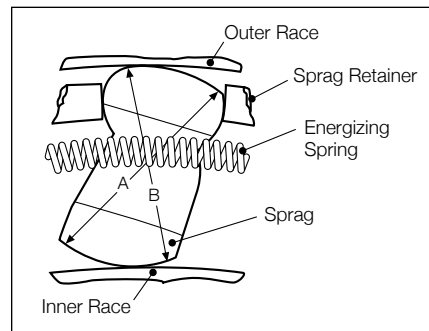
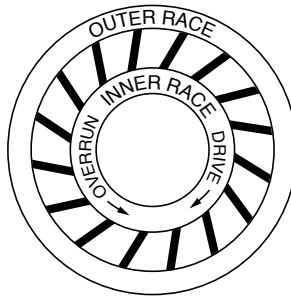
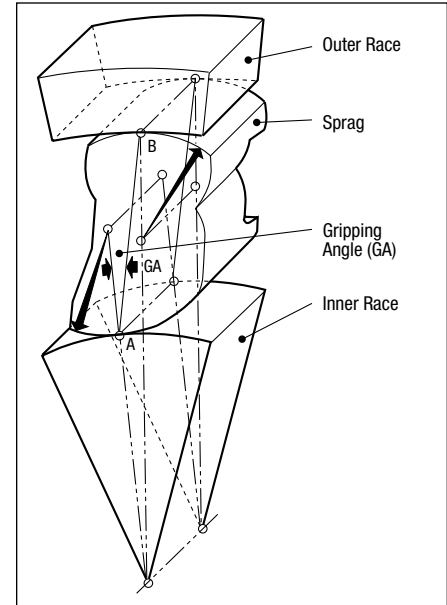

**Figure 1**  
Detail of sprag. Dimension "A" is greater than dimension "B."

## Gripping Angle

Wedging action depends upon the wedging, or gripping angle of the sprags between the races. The fundamental concept of sprag clutches requires that the coefficient of friction of the sprag, with respect to the inner race at the instant torque is applied in the drive direction, must be greater than the tangent of the gripping angle, GA. If the condition is not satisfied, wedging will not occur.

The gripping angle is determined by the construction of Figure 2, where points A and B are the points of contact of the sprag with the inner and outer races, respectively.



**Figure 2**  
Geometry of sprag, showing gripping angle "GA."

Sprags are designed to have a low initial gripping angle to insure positive initial engagement. As torque increases, the sprags produce radial forces which cause race deflections, which make the sprags roll to new positions. Sprags are usually designed to have an increasing gripping angle as they roll from overrunning position to maximum load-carrying position.

A higher gripping angle reduces the radial load imposed by the sprag, thus permitting higher torques to be transmitted within the limits of race stretch and brinelling.

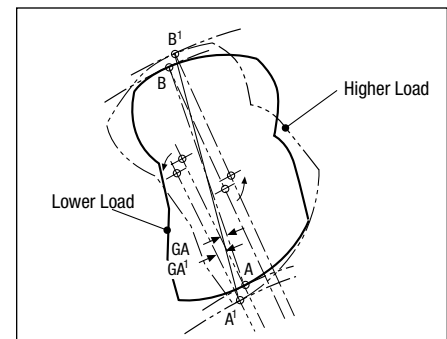

**Figure 3**  
Gripping angle increases as load increases and annular space increases.





Formsprag and Stieber manufacture a wide variety of sprag sizes and shapes to meet the market requirements.

## Free action

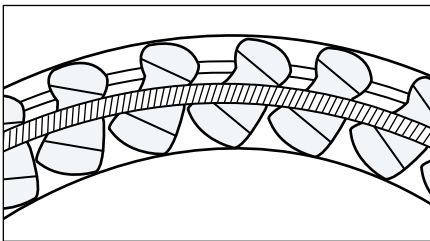

In the Formsprag “free action” retainer all sprags are permitted to have free and independent action. During overrunning this allows each sprag independently to adapt itself to any variations in annular space caused by runout or by foreign matter which may inadvertently get inside the clutch. Since each sprag operates independently, it cannot transfer the effects of variations from one sprag to the next. With all sprags in uniform engagement at all times, the load is evenly distributed. The free action principle also distributes wear evenly for a minimum of wear on all components.

## PCE® sprag

PCE sprags are designed to overcome the effects of severe torsional and linear vibrations as well as high transient torque overloads. It is a Formsprag exclusive. This design, which provides built in protection from otherwise damaging overloads, is now standard in model sizes 300 through 700.

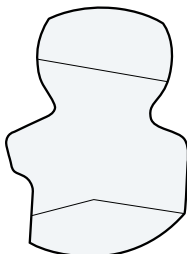

## Sprag Energizing

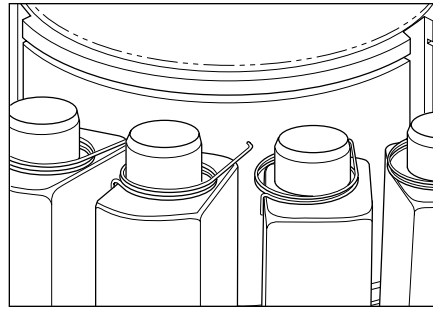

The sprags are energized by springs that act upon each end of each sprag. Formsprag has developed several different types of energizing springs, such as contracting springs, expanding springs and a torsional type spring. In each overrunning clutch the type of energizing spring used will reflect Formsprag’s broad experience in the design and application of overrunning clutches in the choice of a method of energizing best suited for the particular design of clutch.

In all cases, whether the spring is an expanding spring, a contracting spring, or a torsional spring, the spring design energizes each sprag individually without transfer of motion or effect from one sprag to the next.

## The C/T Sprag Principle

Centrifugal Throw-out, or C/T, retainer assemblies are designed for high speed inner or outer race overrunning, and lower speed drive conditions. C/T sprags are available in a variety of models. Model FSO sizes 300 through 700 are available with PCE or C/T sprag option with outer race overrunning.

## Outer Race C/T

In the outer race centrifugally disengaging sprag design, the mass of the sprag is located so that when the outer race is overrunning, the centrifugal force of the sprags overcomes the force of the energizing spring causing the sprags to completely “lift-off” of the inner race.

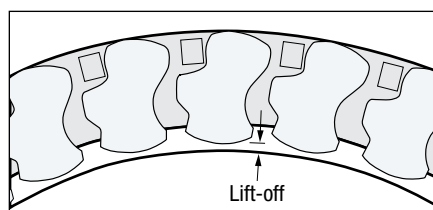

## Inner Race C/T

Model RSBI & RIZ sizes 20 through 240 are available with the inner race C/T feature.

In the inner race centrifugally disengaging sprag design, the mass of the sprag is located so that when the inner race is overrunning the centrifugal force of the sprags overcomes the force of the energizing spring causing the sprags to completely “pull away” from the outer race.

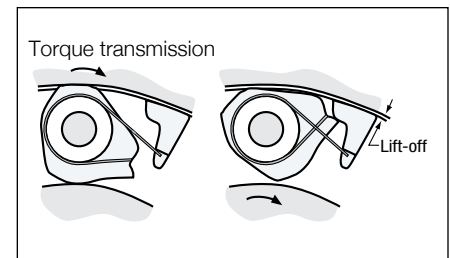

The point at which the sprags lift-off of the inner or outer race is listed as the “lift-off speed.” The maximum drive speed is always less than the lift-off speed to insure positive sprag energizing.

The primary advantage of the centrifugal throw-out sprag retainer is that when the sprags lift-off the inner or outer race there is no rubbing contact in the clutch. Therefore, the life of the clutch is determined by the life of the bearings.

**Note:** In centrifugal throw-out designs, the sprags lift-off the inner or outer race during overrunning. Therefore, for drive conditions, C/T designs require that the driving speed be lower than the lift-off speed.

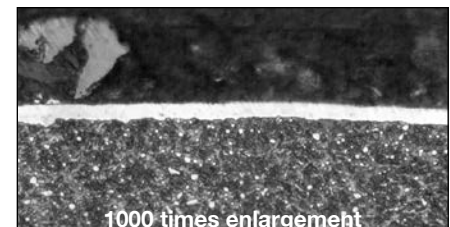

## Formchrome® extends sprag life

Ultra-hard Formchrome sprags provide extra-long life, maximum wear resistance and lower maintenance costs. Formchrome sprags — exclusive with Formsprag — are made by diffusing chromium into the surface of hardened high carbon alloy steel to form a chromium-carbide alloy.

Formsprag and Stieber facilities design and manufacture the largest variety of overrunning, indexing and backstopping clutches in the world. To select the model that would best meet your application requirements, you will need to determine the following:

- Function — Overrunning, Indexing, Backstopping
- Torque Required
- Shaft Size or Required Clutch Bore
- Maximum Inner Race Overrunning Speed
- Maximum Outer Race Overrunning Speed
- Lubrication Preferences or Limitations

With this information use the chart on the adjacent page to select models that meet your requirements. The models are grouped by type of bearing support and mounting requirements. To make the final selection, use the Selection Procedure listed on page 10.

---

## General Purpose Clutches

- **Ball Bearing Supported**
  - FSO
  - HPI
  - FRB
  - FSA
- **Sleeve Bearing Supported**
  - FS-02
  - FSR
- **Bearing Envelope Design**
  - CSK
  - CSK..P
  - CSK..PP
  - ASK
  - GFK
- **Not Self-supporting**
  - ASNU
  - FS-20 and 50
  - DC
  - RSCI
  - AS

---

## Special Purpose Clutches

FS-100, FS-200, FS-300  
HPO  
SB/SBI  
FSD/HBG  
CDU  
RL

---

## Backstopping Clutches

RSBW  
HSB  
LLH  
LCB  
FHB  
HFB/VFB

---

## Modular “Building Block” Clutches

AL  
GFR  
RIZ

---

## Clutch Couplings

AL/ALM..KEED2  
FW, FW (C/T)  
FWW, FWW (C/T)  
RIZ/RAZ..ELG2

---

## Accessories

---

Application						Overrunning Speed (RPM)		Lubrication	
Model	Overrunning	Indexing	Backstopping	Torque Range (lb. ft.)	Bore Range (in.)	Inner Race	Outer Race	Oil/Grease	Page
FSO C/T	X		X	275 – 27,000	0.5 – 7.0	3,000 – 500	6,000 – 1,100	Oil	14
FSO	X	X	X	275 – 27,000	0.4 – 7.0	3,600 – 1,100	900 – 375	Oil/Grease	14
HPI		X		275 – 27,000	0.5 – 7.0	N/A	N/A	Oil	14
FRB	X		X	89 – 11,800	0.4 – 4.4	5,000 – 1,800	340 – 145	Grease	18
FSA	X	X	X	38,000 – 500,000	4.93 – 20.0	400 – 75	50 – 20	Oil/Grease	20
FS-02,04,05	X	X	X	4.5 – 30	0.25 – 0.63	3,450 – 1,800	2,400 – 900	Grease	22
FSR	X	X	X	40 – 1,800	0.37 – 2.19	1,950 – 950	900 – 250	Oil/Grease	24
CSK*	X	X	X	3 – 284	0.3 – 1.57	15,000 – 3,000	15,000 – 3,000	Grease	26
ASK*	X	X	X	53 – 185	1.57 – 2.36	3,500 – 2,500	3,500 – 2,500	Grease	30
GFK*	X	X	X	38 – 339	0.7 – 1.96	5,500 – 3,400	4,000 – 2,200	Grease	32
AS*	X	X	X	1.5 – 784	0.2 – 3.14	5,000 – 600	7,500 – 900	Oil	34
ASNU*	X	X	X	9 – 32,841	0.3 – 7.87	3,300 – 230	5,000 – 350	Oil	36
FS-20 and 50		X	X	39 – 1,250	N/A	2,500 – 1,750	N/A	Oil	38
DC	X	X	X	46 – 3,598	—	—	—	Oil	40
RSCI*	X		X	156 – 70,849	0.7 – 9.4	14,500 – 3,100	0 – 0	Oil	42
FS-100, 200	X	X	X	70 – 440	0.5 – 2.0	1,800 – 1,200	450 – 300	Oil	46
HPO	X		X	3,200 – 18,000	1.9 – 7.0	600 – 300	3,000 – 1,500	Grease	48
SB/SBI	X	X	X	875 – 22,300	0.75 – 7.00	2,500 – 500	800 – 375	Oil/Grease	50
FSD/HBG	X			27,000 – 300,000	6.0 – 8.98	N/A	N/A	Oil	52
CDU	X			1,175 – 45,000	N/A	3,600 – 1,100	3,600 – 1,100	Oil	54
RL				8 – 2,208	0.49 – 2.49	1,800 – 900	N/A	Oil/Grease	58
RSBW*			X	277 – 3,598	1.0 – 3.5	400 – 200	0 – 0	Grease	62
HSB			X	275 – 27,000	0.5 – 7.0	2,900 – 1,050	0 – 0	Oil	64
LLH			X	4,000 – 700,000	1.87 – 20.0	400 – 75	N/A	Oil/Grease	68
FHB			X	1,734 – 4,130	1.1 – 3.7	2,400 – 400	0	Grease	84
HFB/VFB			X	284 – 483	1.0 – 6.0	2,000 – 1,800	0	Grease	88
LCB			X	150 – 850	1.85 – 5.00	0	1800-3600	Grease	86
AL*	X	X	X	41 – 212,175	0.47 – 9.84	2,500 – 100	7,200 – 620	Oil	92
GFR*	X	X	X	41 – 51,660	0.47 – 5.9	4,000 – 200	5,600 – 800	Oil	98
RIZ*	X		X	231 – 12,546	1.1 – 5.1	9,000 – 2,400	0 – 0	Grease	104
AL..KEED2*	X			41 – 184,500	0.47 – 9.8	2,500 – 100	6,000 – 620	Oil	110
FW	X			107 – 27,000	0.37 – 6.5	2,800 – 500	850 – 375	Oil/Grease	114
FW (C/T)	X			107 – 27,000	0.37 – 6.5	2,800 – 500	5,000 – 1,100	Oil	114
FWW	X			276 – 7,000	0.37 – 5.75	2,800 – 1,000	850 – 650	Oil/Grease	114
FWW (C/T)	X			276 – 7,000	0.37 – 5.75	2,800 – 1,000	5,000 – 1,800	Oil	114
RIZ..ELG2*	X			231 – 12,454	1.1 – 5.1	9,000 – 2,400	—	Grease	112

\* Stieber Metric Designs

# Selection Guide

## Selection Procedure

When a clutch is to be selected on the basis of torque calculation, follow the eleven steps below:

1. Calculate **load torque** to be transmitted by the clutch.  
$$\text{Torque (lb.ft.)} = \frac{5250 \times \text{HP}}{\text{RPM}}$$
or  
$$\text{Torque (Nm)} = \text{lb.ft.} \times 1.356$$
2. Select the proper service factor from the appropriate table on page 13.
3. Determine the **design torque** by multiplying the load torque by the service factor.
4. Check the key and shaft stress before making a final clutch selection since this may determine the maximum allowable drive torque capacity.
5. Determine the overrunning and drive speed along with which race will overrun.
6. Select a clutch **MODEL** and **SIZE** from the catalog based on design torque, bore size, overrunning speed and dimensions for proper fit into the available space.
7. If the **outer race** is the overrunning member, then determine if the C/T option can be used for the clutch model selected.
  - a. A Centrifugal Throwout (C/T) model clutch may be used if the drive speed is less than the maximum C/T drive speed and the overrunning speed is higher than the lift-off speed.
  - b. A C/T model clutch may not be used when the drive speed is higher than the maximum C/T drive speed.
  - c. For overrunning speeds other than listed, contact the factory.
8. When higher speeds are required select the LABYRINTH GREASE SEAL option listed in the Specification chart for each clutch model or contact Formsprag Application Engineering Department.

9. Determine the shaft size, bore and key size requirement of the clutch from the catalog. Refer to the **BORE SIZES/ SHAFT TOLERANCES** chart on pages 128 and 129 for the **ACTUAL BORE SIZE** that will be supplied with the clutch. If the actual bore size required is other than that listed, contact the factory.
10. Select the type of **LUBRICANT, oil or grease**, for the clutch model where appropriate. It should be noted that many of the clutch model are available in either oil or grease only. If the Labyrinth grease seal option is selected in step 8 above, the clutch must be **grease** lubricated.
11. Determine the **DIRECTION OF ROTATION** for the model selected where necessary. When viewing the clutch from the end as shown in the catalog, **if the inner race is to rotate freely in the CCW direction and drive in the CW direction it is a Right Hand (RH) rotation. Left Hand (LH) is opposite.** See clutch rotation on page 12.

The torque values listed in this catalog are based upon normal use with 1 million load cycles at full catalog torque and receiving proper care and maintenance. For Models FSO, HPI, FSA and SB the torque ratings are based upon using only one end face to transmit.

**Caution:** Consult factory for reciprocated type prime mover and any inclined or vertically mounted applications.

## Special Designs

While the wide range of sizes and capacities covered by this catalog's line of clutches will cover substantially all industrial needs, it is sometimes necessary to design and build clutches to meet specialized requirements.

Special designs can also take advantage of a self-contained lubrication system or lubricant contained within the customer's machine. In such cases, lubrication could be introduced through the inner race or through clutches assembled without seals to permit a free flow of oil through the clutch. Since other factors may affect selection of clutches in both indexing and holdback cases, consult our Application Engineering Department for assistance.

When placing an order always use the part number in addition to the model number if available.

The **part number** is marked on the clutch and listed in the price sheets. There is a unique part number for each design and bore combination and the format is as follows:

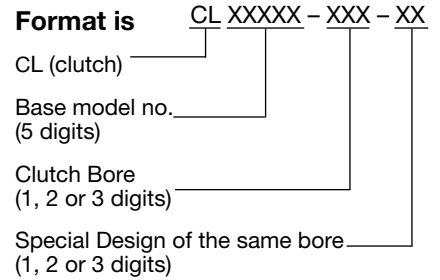

Example is CL42156-123-2

The model number is marked on the clutch and listed in the product catalog.

### Example:

1. FSO 700 model clutch, optional C/T retainer, 2.2485/2.2500" bore, .625 x .32 keyseat, oil lubricated.
2. FSR - 16 model clutch, 1.000/1.001" bore, .50 x .25 keyseat, grease lubricated, right hand rotation.
3. HPI 900 model clutch, optional Labyrinth grease seals, 4.498/4.500" bore, 1.00 x .50 keyseat, grease lubricated.

### Example:

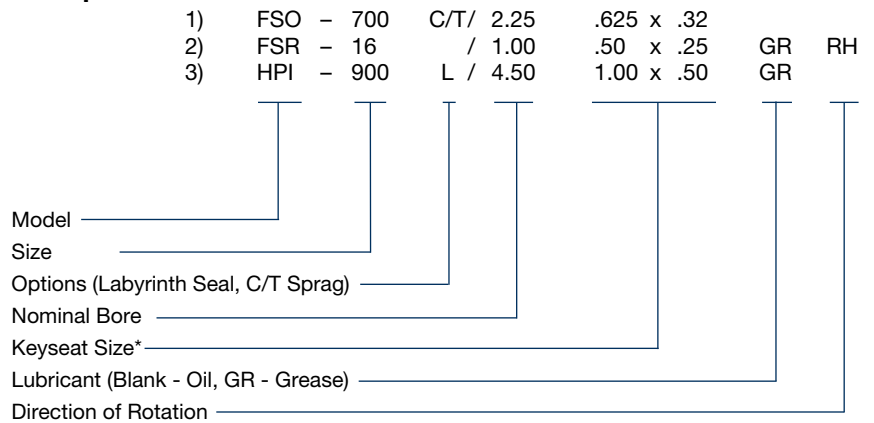

\* If keyseat is not specified when ordering, the clutch will be supplied with the available standard keyseat.

# Selection Guide

## Overrunning Clutches

### Overrunning Speeds

This is the maximum speed differential between the inner and outer races. When one race is stationary and the other overruns, clutch selection may be based on maximum overrunning speeds shown in the catalog.

### Same direction of rotation

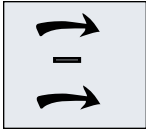

If both races rotate in the same direction at different speeds, the overrunning speed is the *difference* in their speeds.

### Opposite direction of rotation

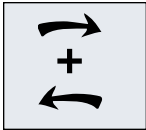

If the races rotate in opposite directions, the overrunning speed is the *sum* of their speeds.

### Drag Torque

In an overrunning clutch the drag or resistance to freely turn is a result of the additive values of seal drag, bearing drag and sprag energizing drag. This clutch drag torque is noted as “resistance after run-in” and is listed for each model on its data page. The drag (resistance after run-in) torque values for new clutches will be higher at first and after 12 to 24 hours of overrunning at standard motor speeds will reduce to catalog-listed values. When a clutch is overrunning, the drag torque is exerted upon the lower speed race and any attached drive components.

## Indexing Clutches

### Dynamic Load

The torque required to accelerate the indexing mechanism and load, increases rapidly as the angle of index and number of cycles per minute increases. This torque should be calculated and added to other torque values in the system. For equation, see Overrunning Clutch Application Manual P-1052.

### Brake Torque

If a brake is used in the indexing system, the resistance of the brake must be calculated in terms of torque and added to the other torque values in the system.

### Stock Load

If, as in a punch press feed device, the indexing mechanism must pull stock from a coil, the force required to do this must be added. This load can best be determined by actual measurements.

## Clutch rotation

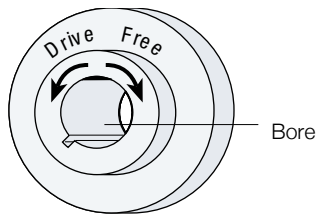

Left Hand Rotation Shown

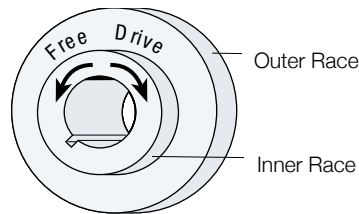

Right Hand Rotation Shown

If the overrunning clutch design is not symmetrical, then the clutch rotation will need to be determined, and this information (RH or LH) must be provided at time of order placement.

To establish rotation of a clutch, look at the clutch from the end specified by the arrow for each clutch series. If the inner race drives the outer race in the clockwise direction it is a right hand rotation. For Clutch Couplings see page 114.

## Service Factors



### Formsprag and Stieber Overrunning Clutches

Clutches are suitable for many different power transmission applications. Please refer to this table for the proper service factor for your application.

Typical prime movers are listed at the left, types of loads across the top, and your service factor opposite the typical prime movers.

When torsional or linear vibration is present, use an FSO series clutch and increase the service factor at least 50%. For severe vibration, a greater service factor increase is necessary. To conform with couplings manufacturer's recommendations, use a minimum service factor of 1.5 on all Clutch Couplings.

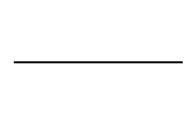
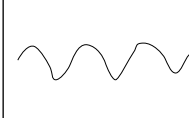
## Overrunning & Backstopping Applications Service Factors

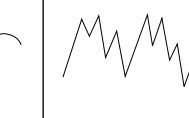
		Driven Equipment Load Classifications			
		Light Steady Loads Starting torque is equal to or slightly greater than running torque.	Moderate Loads High starting torque or above average running torque.	Medium Loads Starting torque is approximately double running torque.	Heavy-Duty Loads High starting torque, shock loading, light torque reversals during drive.
					
		Centrifugal pumps, uniformly loaded conveyors, light-duty fans and blowers, liquid mixers and agitators, centrifugal compressors, lobe and vane type blowers, gear pumps, textile machinery, woodworking machinery.	Hot oil pumps, heavy-duty centrifugal pumps, cooling towers, slurry agitators, boiler feed pumps, hoists, conveyors.	Dredge pumps, dynamometer drives, light-duty hammermills, lineshafts, paper-converting machinery, rotary kilns, rotary or screw-type pumps for high viscosity fluids.	Mine ventilating fans, reciprocating pumps or compressors, papermaking machinery, heavy-duty hammermills, ore crushers, pulverizing mills.
Prime Mover	Steam, gas or air turbine	1.00	1.50	1.50	2.50
	AC electric motor	1.25	1.50	1.50	2.50
	DC electric motor with DOL start AC electric motor	1.25	1.50	1.75	3.00
	Gasoline, natural gas, propane or other spark ignition engine	3.0	3.0	Consult Formsprag	Consult Formsprag
	Diesel	Consult Formsprag	Consult Formsprag	Consult Formsprag	Consult Formsprag

DOL = Direct on Line

## Indexing Applications Service Factors

Type of Load	FS-02, 04, 05 FSR-3 & 5	FSR 6 to 16 HPI	FSO	Roller Design
Less than 90° or less than 150 strokes/min.	3	2	2	2
Over 150 strokes/min.	4	2	N/A	3
When angle is greater than 90° and over 200 strokes/min.	4	2	N/A	2.5

\* Recommended for maximum performance and maximum life.

**Note:** In all cases where considerable vibration is present, a higher service factor may be needed (possibly up to 6).

# General Purpose Clutches

## FSO/HPI

### Overrunning, Indexing, Backstopping Ball Bearing Supported, Sprag Clutches



All models contain **PCE** sprags with Formchrome® and Formsprag “Free-action” retainers except models FSO 550 & FSO 650. Standard clutches and all C/T clutches are oil lubricated. Grease lubrication is available for applications where maintenance is inadequate, or where higher inner race overrunning speeds are required. These clutches mount on a through-shaft, with the inner race driven by a key. The ground O.D. of the outer race is designed as a pilot or mounting surface for attaching parts and is concentric with the bore. Tapped holes are provided in each end of the outer race for securing these parts to the clutches. Refer to Bore Sizes/Shaft Tolerances chart for mounting data, page 128.

For vertical mounting, contact Application Engineering.

### Model FSO

General purpose, ball-bearing clutches suitable for overrunning, backstopping and light to medium-duty indexing applications. They are oil lubricated and equipped with lip type seals. Grease is available. Increased speeds are possible with steel labyrinth seals.

### C/T Sprag Models (FSO Only)

C/T sprag clutches are ideal for applications with high speed outer race overrunning and low speed driving. Available with oil lubrication only.

### Model HPI

Especially designed for **medium to heavy-duty** indexing applications, or applications in excess of 150 strokes/min. to provide the maximum in dependable, uniform, long life performance except models FSO 550 & FSO 650. They are oil lubricated and equipped with lip type seals. Grease is available.

### Oil Lubricated Clutches

FSO-300 through 700 clutches are shipped from the factory with Mobil DTE Heavy Medium oil.

HPI-300 through 700 clutches are shipped from the factory with Mobil DTE Light oil.

### Grease Lubricated Clutches

FSO-300 through 700 clutches are shipped from the factory packed with Fiske Brothers Lubriplate Low-Temp grease.

HPI-300 through 700 clutches are shipped from the factory with Fiske Brothers Lubriplate Low-Temp grease.

OSHA cover kits are available for Models FSO & HPI-400 through 700, see page 125 for details.

For further information, write for Installation and Maintenance Bulletin No. 2219, P-222-10 for the FSO series and No. 2213, P-222-6 for the HPI series.

### Typical Mounting Arrangement

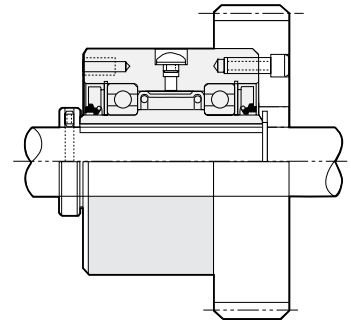

The Model FSO clutches must be axially restrained, see accessories page 122 for set collars, restraint keys and OSHA covers, etc. All fasteners are recommended to be grade 8 bolts.

## Specifications

Size	Torque Capacity lb.ft. (Nm)	Maximum RPM								Resistance after run-in lb.ft. (Nm)	Lubrication		Shipping Weight lb. (kg)
		Standard Models				C/T Sprag Models					Oil or Grease	Oil only	
		Overrunning Speed				Overrunning Speed							
		Oil and Grease Lip Seals		Labyrinth Grease Seals		Overrunning Speed		Max. drive	Sprag lift-off		FSO oz (ml)	HPI oz (ml)	
		Inner Race	Outer Race	Inner Race	Outer Race	Inner Race	Outer Race						
300	275 (374)	3,000	900	3,600	900	3,000	6,000	1,100	1,300	.13 (.18)	.25 (7.0)	.50 (14.0)	3.5 (1.6)
400	300 (408)	2,800	850	3,600	850	2,800	5,000	1,100	1,300	.20 (.27)	.33 (9.9)	.67 (19.8)	6 (2.7)
500	1,175 (1598)	2,500	800	3,000	800	2,500	4,000	1,000	1,200	.23 (.31)	.75 (22.0)	1.25 (35.0)	10.5 (4.8)
550	1,885 (2564)	1,175	800	—	—	—	—	—	—	.35 (.47)	1.75 (52.0)	—	12 (5.4)
600	2,250 (3060)	2,200	750	2,400	750	2,200	3,600	1,000	1,200	.46 (.62)	1.75 (52.0)	3.00 (84.0)	19 (8.6)
650	2,375 (3230)	900	600	—	—	—	—	—	—	.80 (1.08)	6.00 (168.0)	—	24 (10.8)
700	5,000 (6800)	1,600	450	2,000	450	1,600	2,500	800	1,000	1.15 (1.56)	6.00 (168.0)	10.00 (280.0)	42 (19)

**Note:** Check key and shaft stress before making final clutch selection since this may determine the maximum allowable drive torque capacity. Shaft keys are not provided with the clutches on sizes 300 through 700.



FSO OSHA cover kits are designed for shaft end mounted FSO or HPI clutches and available from Formsprag from size 400 through 1027. These cover kits provide not only the stationary cover enclosure required by OSHA, but provide additional protection for the clutch from abrasive environments as well.

**Note:** OSHA requires that a stationary guard must enclose clutches with rotating projecting parts and operating seven (7) feet or less above the floor.

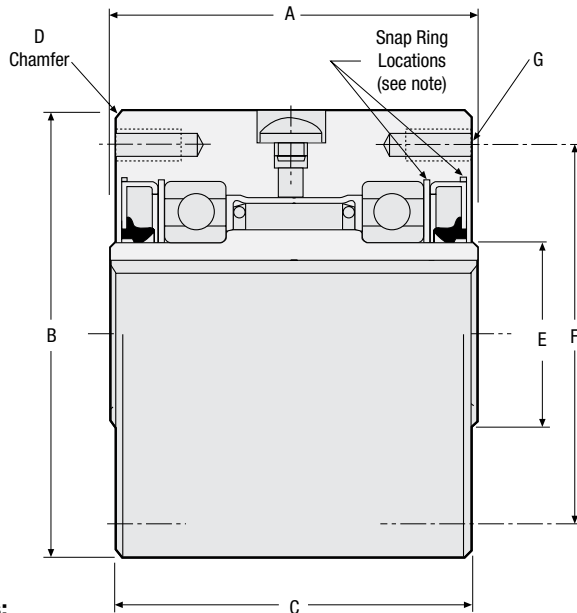

**Notes:**

Angle — oil hole to mounting bolt hole

Model 300, 400, 500= 45°

600 = 15°

700 = 0° or 30° (offset from center of outer race)

Snap ring is located on the outboard side of the oil seal on Models 400, 600 and 700. On Models 300 and 500, snap ring is inboard of the oil seal.

**Dimensions** inches (mm)

Size	A	B	C	D	E	F	G		
							Number	Thread	Depth
300	2.50 (63.50)	3.000/2.998 (76.20/76.15)	2.38 (60.45)	.06 x 45° (1.58 x 45°)	1.12 (28.58)	2.625 (66.67)	4 @ 90°	.250-28	.50 (12.70)
	400	2.75 (69.85)	3.500/3.498 (88.90/88.85)	2.69 (68.26)	.06 x 45° (1.58 x 45°)	1.19 (30.15)	2.875 (73.02)	4 @ 90°	.312-24
500		3.50 (88.90)	4.250/4.248 (107.95/107.90)	3.38 (85.72)	.06 x 45° (1.58 x 45°)	1.77 (45.0)	3.625 (92.07)	4 @ 90°	.312-24
550	3.25 (82.55)	4.750/4.748 (120.65/120.60)	3.125 (79.38)	0.08	2.75 (69.85)	4.25 (107.95)	6 @ 60°	.312-24	.54 (13.72)
									2.50 (63.50)
600	3.75 (95.25)	5.375/5.373 (136.53/136.47)	3.63 (92.07)	.06 x 45° (1.58 x 45°)	2.72 (69.09)	4.750 (120.65)	6 @ 60°	.312-24	.63 (15.87)
									2.50 (63.50)
650	3.50 (88.90)	6.500/6.498 (165.1/165.05)	3.375 (85.72)	0.09	3.187 (80.94)	5.75 (146.05)	8	.375-24	.79 (20.06)
700	5.00 (127.00)	7.125/7.123 (180.97/180.92)	4.88 (123.82)	.06 x 45° (1.58 x 45°)	3.56 (90.42)	6.250 (158.75)	8†	.375-24	.75 (19.05)
									4.00 (101.60)

**Notes:**

† Six holes equally spaced at 60° plus two extra holes at 180°. Six hardened mounting screws are adequate for torque loads up to 3000 lb.ft. (4068 Nm). Use eight hardened mounting screws for torque loads above these values.

‡ The "E" dimension is larger for this bore size.

**Bore sizes and keyseats\*\*\*\***

inches (mm)

Size	Bore Size	Keyseat	Bore Range	
			Min.	Max.
300	.500 (12.70)	1/8 x 1/16 (3.18 x 1.57)	.500 (12.70)	.750 (19.05)
	.625 (15.87)	3/16 x 3/32 (4.75 x 2.36)		
	15mm	5 x 2.3mm***		
	.750 (19.05)	3/16 x 3/32 (4.75 x 2.36)		
400	.500 (12.70)	1/8 x 1/16 (3.18 x 1.57)	.437 (11.10)	.875 (22.22)
	.625 (15.87)	3/16 x 3/32 (4.75 x 2.36)		
	18 mm	6 x 2.8mm***		
	.750 (19.05)	3/16 x 3/32 (4.75 x 2.36)		
	.875 (22.22)	3/16 x 1/16 (4.75 x 1.57)		
	.875 (22.22)	3/16 x 3/32 (4.75 x 2.36)		
500	1.000 (25.40)	1/4 x 1/8 (6.35 x 3.18)	.750 (19.05)	1.312 (33.32)
	1.125 (28.57)	1/4 x 1/8 (6.35 x 3.18)		
	30mm	10 x 3.3mm***		
	1.250 (31.75)	1/4 x 1/8 (6.35 x 3.18)		
	1.312 (33.32)	1/4 x 3/32 (6.35 x 2.29)		
	1.250 (31.75)	1/4 x 1/8 (6.35 x 3.18)		
	1.312 (33.32)	3/8 x 3/16 (9.52 x 4.75)		
	1.5000 (38.10)	3/8 x 3/16 (9.52 x 4.75)		
	1.625 (41.27)	3/8 x 1/8 (9.52 x 3.18)		
	1.250 (31.75)	1/4 x 1/8 (6.35 x 3.18)		
600	1.375 (34.92)	3/8 x 3/16 (9.52 x 4.75)	.937 (23.80)	2.250* (57.15)
	1.5000 (38.10)	3/8 x 3/16 (9.52 x 4.75)		
	40mm	12 x 3.3mm***		
	1.625 (41.27)	3/8 x 3/16 (9.52 x 4.75)		
	1.750 (44.45)	3/8 x 3/16 (9.52 x 4.75)		
	45mm	14 x 3.8mm***		
	50mm	14 x 3.8mm***		
	2.000 (50.80)	3/8 x 1/8 (9.52 x 3.18)		
	1.937 (49.20)	1/2 x 1/4 (12.70 x 6.35)		
	2.000 (50.80)	1/2 x 1/4 (12.70 x 6.35)		
	2.250 (57.15)	1/2 x 1/4 (12.70 x 6.35)		
	2.437 (61.90)	5/8 x 1/8 (15.87 x 3.18)		
700	2.500 (63.50)	5/8 x 1/8 (15.87 x 3.18)	1.875 (47.62)	3.250*** (82.55)
	1.937 (49.20)	1/2 x 1/4 (12.70 x 6.35)		
	50mm	14 x 3.8mm		
	2.000 (50.80)	1/2 x 1/4 (12.70 x 6.35)		
	2.250 (57.15)	1/2 x 1/4 (12.70 x 6.35)		
	60mm	18 x 4.4mm***		
	2.437 (61.90)	5/8 x 5/16 (15.87 x 7.93)		
	2.500 (63.50)	5/8 x 5/16 (15.87 x 7.93)		
	65mm	18 x 4.4mm***		
	2.750 (69.85)	5/8 x 7/32 (15.87 x 5.53)		
70mm	20 x 4.9mm***			
2.937 (74.60)	5/8 x 1/8 (15.87 x 3.18)			
75mm	20 x 4.9mm***			
80mm	22 x 5.4mm***			

\* 1/2 x 1/8 keyway. \*\* 3/4 x 1/4 keyway.

\*\*\* Contact Formsprag for keyseat information.

\*\*\*\* For Bore Sizes/Shaft Tolerances, see page 128.

† The "E" dimension is larger for this bore size.

# General Purpose Clutches

## FS/FSO/HPI

### Overrunning, Indexing, Backstopping Ball Bearing Supported, Sprag Clutches



All models contain Formchrome® sprags and Formsprag “Free-action” retainers. These clutches mount on a through-shaft, with the inner race driven by a key. *Standard keys are supplied by Formsprag at no additional charge.* The ground O.D. of the outer race is designed as a pilot or mounting surface for attaching parts and is concentric with the bore. Tapped holes are provided in each end of the outer race for securing these parts to the clutch. Refer to Bore Sizes/Shaft Tolerance chart for mounting data, page 128.

For vertical mounting, contact Application Engineering.

### Model FSO

Allows higher inner race overrunning speeds than FS series. They are also suitable for general overrunning and light- to medium-duty indexing applications.

### Specifications

Size	Torque Capacity lb.ft. (Nm)	Maximum RPM								Resistance after run-in lb.ft. (Nm)	Lubrication			Shipping Weight lb. (kg)
		Standard Models				C/T Sprag Models*					Grease	Oil		
		Overrunning Speed				Overrunning Speed						FSO oz (ml)	HPI oz (ml)	
		Lip Seal FS & FSO		Labyrinth FSO		Overrunning Speed		Max. drive	Sprag lift-off					
		Inner Race	Outer Race	Inner Race	Outer Race	Inner Race	Outer Race							
750	7,000 (9520)	1,000	650	1,800	650	1,000	1,800	650	800	3.75 (5.08)	7.5 (222)	13 (384)	7 (207)	83 (38)
800	13,000 (17,680)	850	525	1,500	525	850	1,500	525	675	5.25 (7.12)	7.5 (222)	15 (444)	8.5 (251)	102 (46)
900	18,000 (24,480)	700	500	1,350	500	700	1,350	500	650	6.25 (8.47)	18 (532)	16 (473)	11.5 (340)	156 (71)
1027	27,000 (36,720)	500	375	1,100	375	500	1,100	375	475	10.00 (13.56)	22 (651)	32 (946)	16 (473)	250 (113)

#### Notes:

\* FSO-1027 C/T Sprags are not Formchromed.

Check key and shaft stress before making final clutch selection since this may determine the maximum allowable drive torque capacity.

FSO-750 only, shipped with labyrinth seals.

Shaft keys are provided with the clutches on sizes 750 and up.

They are grease lubricated and equipped with grease seals.

### Model HPI

Are especially designed for medium to heavy-duty indexing applications, or applications in excess of 150 strokes/ min. to provide the maximum in dependable, uniform, long life performance. They are oil lubricated and equipped with lip type seals. Grease is available.

### Model FS

Suitable for general overrunning, backstopping and light- to medium-duty indexing applications. They are oil lubricated and equipped with lip-type seals.

### C/T Sprag Models (FS Only)

Ideal for applications with high speed outer race overrunning and low speed driving. Available with oil lubrication only.

### Oil Lubricated Clutch

FS-750 through 1027 clutches are shipped from the factory with Mobil DTE Heavy Medium oil.

HPI-750 through 1027 clutches are shipped from the factory with Mobil DTE Light oil.

### Grease Lubricated Clutch

FSO-750 through 1027 clutches are shipped from the factory packed with Fiske Brothers Aero-Lubriplate grease.

HPI-750 through 1027 clutches are shipped from the factory with Fiske Brothers Aero-Lubriplate grease.

OSHA cover kits are available for Models FS, FSO & HPI-750 through 1027, see page 125 for details.

For further information, see *Installation and Maintenance* bulletin No. 2219, P-222-10 for FS and FSO series, and No. 2213, P-222-6 bulletin for the HPI series.

### Typical Mounting Arrangement

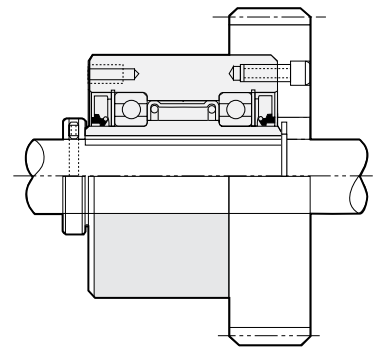

The Model FSO clutches must be axially restrained, see accessories page 122 for set collars, restraint keys and OSHA covers, etc. All fasteners are recommended to be grade 8 bolts.

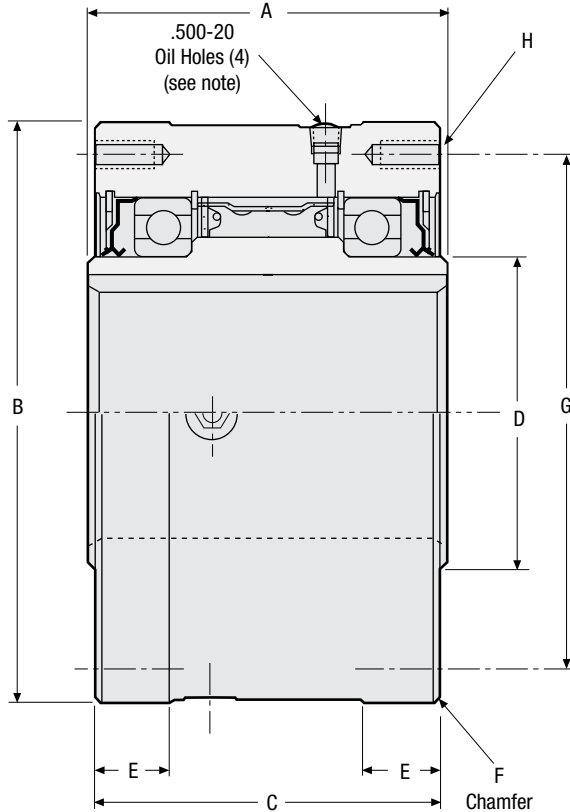

### Notes:

Angle — oil hole to mounting bolt hole

Model 750 = 0° or 30°

900 = 0° or 18°

800 = 0° or 45°

1027 = 15°

### Dimensions inches (mm)

Size	A	B	C	D	E	F	G	H		
								Number	Thread	Depth
750	6.00 (152.4)	8.750/8.748 (222.25/222.20)	5.88 (149.22)	4.25 (107.95)	1.25 (31.75)	.06 x 45° (1.58 x 45°)	7.00 (177.80)	8*	.500-20	1.00 (25.40)
800	6.00 (152.4)	10.000/9.998 (254.00/253.95)	5.88 (149.22)	5.50 (139.70)	1.25 (31.75)	.06 x 45° (1.58 x 45°)	8.94 (227.01)	8 @ 45°	.500-20	1.00 (25.40)
900	6.38 (161.9)	12.000/11.997 (304.80/304.72)	6.25 (158.75)	6.38 (161.92)	1.38 (34.92)	.06 x 45° (1.58 x 45°)	9.75 (247.65)	10 @ 36°	.625-18	1.25 (31.75)
1027	6.63 (168.3)	15.000/14.997 (381.00/380.92)	6.50 (165.10)	9.00 (228.60)	1.38 (34.92)	.13 x 45° (3.17 x 45°)	11.75 (298.45)	12 @ 30°	.625-18	1.00 (25.40)

\* Six holes equally spaced at 60° plus two extra holes at 180°. Six hardened mounting screws are adequate for torque loads up to 5100 lb.ft. (6915 Nm). Use eight hardened mounting screws for torque loads above these values.

\*\* For finished dimensions of keys supplied with the clutch, contact Formsprag.

### Bore sizes and keyseats\*\*†

inches (mm)

Size	Bore Size	Keyseat	Bore Range				
			Min.	Max..			
750	2.437 (61.90)	5/8 x 5/16 (15.87 x 7.94)	2.250 (57.15)	3.437 (87.30)			
	2.500 (63.50)	5/8 x 5/16 (15.87 x 7.94)					
	65mm	18 x 4.4mm***					
	2.750 (69.85)	5/8 x 5/16 (15.87 x 7.94)					
	70mm	20 x 4.9mm***					
	2.937 (74.60)	3/4 x 3/8 (19.05 x 9.52)					
	75mm	20 x 4.9mm***					
	3.000 (76.20)	3/4 x 3/8 (19.05 x 9.52)					
	80mm	22 x 5.4mm***					
	3.250 (82.55)	3/4 x 1/4 (19.05 x 6.35)					
	3.437 (87.30)	3/4 x 3/16 (19.05 x 4.75)					
	800	3.000 (76.20)			3/4 x 3/8 (19.05 x 9.52)	2.625 (66.67)	4.437 (112.70)
		80mm			22 x 5.4mm***		
		3.250 (82.55)			3/4 x 3/8 (19.05 x 9.52)		
85mm		22 x 5.4mm***					
3.437 (87.30)		7/8 x 7/16 (22.23 x 11.11)					
3.500 (88.90)		7/8 x 7/16 (22.23 x 11.11)					
90mm		25 x 5.4mm***					
3.750 (95.25)		7/8 x 7/16 (22.23 x 11.11)					
100mm		28 x 6.4mm***					
3.937 (100.00)		1 x 1/2 (25.40 x 12.70)					
4.000 (101.60)		1 x 1/2 (25.40 x 12.70)					
4.250 (107.95)		1 x 3/8 (25.40 x 9.52)					
110mm		28 x 6.4mm***					
4.437 (112.70)		1 x 1/4 (25.40 x 6.35)					
900	100mm	28 x 6.4mm***	3.625 (92.07)	5.437 (138.10)			
	4.000 (101.60)	1 x 1/2 (25.40 x 12.70)					
	4.250 (107.95)	1 x 1/2 (25.40 x 12.70)					
	110mm	28 x 6.4mm***					
	4.437 (112.70)	1 x 1/2 (25.40 x 12.70)					
	4.500 (114.30)	1 x 1/2 (25.40 x 12.70)					
	120mm	32 x 7.4mm***					
	4.750 (120.65)	1 x 1/2 (25.40 x 12.70)					
	4.937 (125.40)	1 x 3/8 (25.40 x 9.52)					
	5.000 (127.00)	1 x 3/8 (25.40 x 9.52)					
	130mm	32 x 7.4mm***					
	5.250 (133.35)	1 x 1/4 (25.40 x 6.35)					
	5.437 (138.10)	1 x 1/4 (25.40 x 6.35)					
	1027	4.937 (125.40)			1 1/4 x 5/8 (31.75 x 15.87)	4.937 (125.40)	7.000 (177.80)
130mm		36 x 8.4mm***					
150mm		45 x 10.4mm***					
6.000 (152.40)		1 1/4 x 5/8 (31.75 x 15.87)					
6.250 (158.75)		1 1/2 x 1/2 (38.10 x 12.70)					
6.625 (168.27)		1 1/2 x 1/2 (38.10 x 12.70)					
6.750 (171.45)		1 1/2 x 1/2 (38.10 x 12.70)					
6.875 (174.62)		1 1/2 x 1/2 (38.10 x 12.70)					
175mm		45 x 10.4mm***					
7.000 (177.80)		1 1/2 x 7/16 (38.10 x 11.10)					

\*\* Contact Formsprag for keyseat information.

† For Bore Sizes/Shaft Tolerances, see page 128.

# General Purpose Clutches

## FRB

### Overrunning, Backstopping Ball Bearing Supported, Sprag Clutches



FRB clutch is a high speed, centrifugal throw-out (C/T) Sprag design, supported by sealed ball bearings. The C/T Sprags are designed to “lift-off” from the races during high speed inner race overrunning. In this design, the center of mass of the Sprag is located so that when the inner race is overrunning, the centrifugal force of the Sprag overcomes the force of the energizing springs causing the Sprags to completely “pull away” from the races. The advantage of using C/T Sprags is that, when overrunning at above the lift-off speed, there is no contact between the Sprags and the races so there is no wear (for a longer operating life), no heat being generated (the clutch runs cooler), no Sprag drag so the resistance after run-in is lower. With sealed bearing this design is almost virtually maintenance free.

#### Grease Lubricated Clutches

The Model FRB is excellent for use as backstops by mounting the clutch’s inner race on the rotating shaft and attaching or anchoring the clutch’s outer race with a torque arm to a stationary member of the equipment. The Model FRB can also be used in applications that require low driving speeds and high inner race overrunning speeds.

The C/T Sprag feature provides no Sprag contact or wear during overrunning when operated above the Sprag lift-off speeds. The typical recommended maintenance is to replace the bearings every three years. The Sprag assembly and races are to be re-lubricated with a thin coat of grease for corrosion protection at this time.

For further information, see Installation and Maintenance Bulletin No. 3045, P-4050 for the FRB Series.

#### Typical Mounting for Overrunning Applications

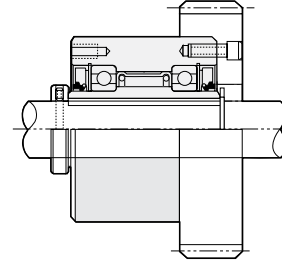

#### Typical Mounting for Backstopping Applications

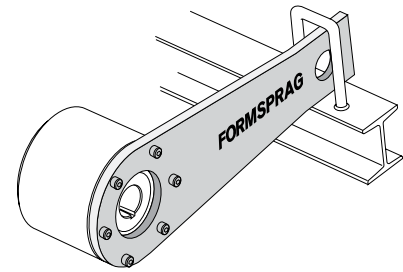

The Model FRB clutches must be secured to the shaft by customer supplied snap ring, set collar, spacer, etc. All fasteners are recommended to be grade 8.

### Specifications

Size	Torque Capacity lb.ft. (Nm)	Maximum RPM				Resistance after run-in lb.ft. (Nm)	Lubrication Oil/Grease	Shipping Weight lb. (kg)
		Inner Race (RPM)	Outer Race (RPM)	Max. Drive Speed (RPM)	Sprag Lift-off Speed (RPM)			
400	89 (120)	5,000	340	340	820	.07 (.09)	Grease	6 (2.7)
500	510 (690)	4,000	330	330	700	.08 (.1)	Grease	10.5 (4.8)
600	810 (1100)	3,600	250	250	610	.15 (.21)	Grease	19 (8.6)
650	2,080 (2820)	4,000	210	210	510	.27 (.36)	Grease	24 (10.8)
700	2,700 (3660)	2,500	195	195	470	.38 (.52)	Grease	42 (19)
750	3,900 (5280)	1,800	210	210	480	1.25 (1.7)	Grease	83 (38)
800	11,800 (16000)	1,800	145	140	400	1.75 (2.38)	Grease	102 (46)

**Note:** Check key and shaft stress before making final clutch selection since this may determine the maximum allowable drive torque capacity.

# General Purpose Clutches

**FRB**

OSHA cover kits are designed for shaft end mounted FRB clutches and available from Formsprag from size 400 through 800. These cover kits provide not only the stationary cover enclosure required by OSHA, but provide additional protection for the clutch from abrasive environments as well.

**Note:** OSHA requires that a stationary guard must enclose clutches with rotating projecting parts and operating seven (7) feet or less above the floor.

## FRB 400-700

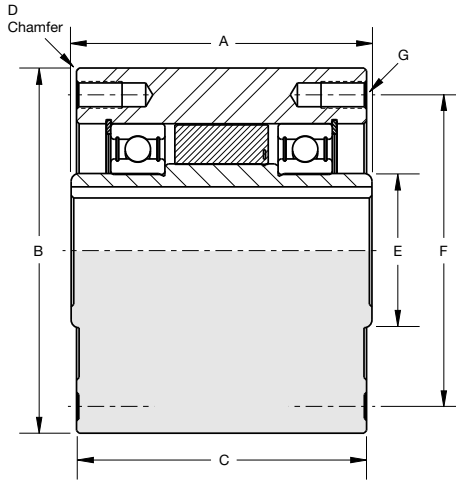

## FRB 750-800

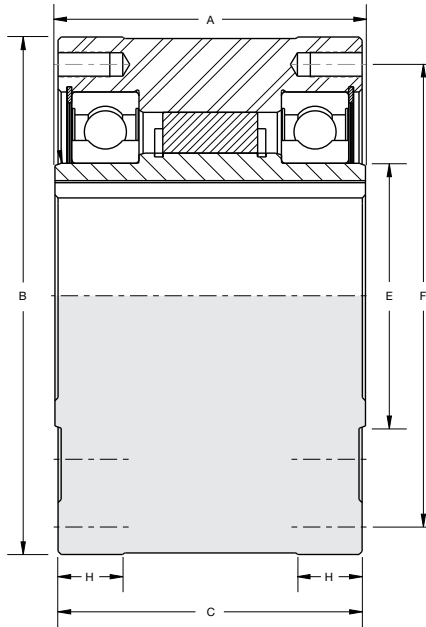

### Dimensions inches (mm)

Size	A	B	C	D	E	F	G			H
							Number	Thread	Depth	
400	2.75 (69.85)	3.500/3.498 (88.90/88.85)	2.69 (68.26)	.06 x 45° (1.58 x 45°)	1.18 (29.97)	2.875 (73.02)	4 @ 90°	.312-24	.63 (16.00)	—
500	3.50 (88.90)	4.250/4.248 (107.95/107.90)	3.38 (85.72)	.06 x 45° (1.58 x 45°)	1.77 (45.0)	3.625 (92.07)	4 @ 90°	.312-24	.63 (15.87)	—
600	3.75 (95.25)	5.375/5.373 (136.53/136.47)	3.62 (91.95)	.06 x 45° (1.58 x 45°)	2.56 (65.02) 2.72 (69.09)	4.750 (120.65)	6 @ 60°	.312-24	.63 (15.87)	—
650	3.50 (88.90)	6.500/6.498 (165.1/165.05)	3.375 (85.72)	0.09	3.15 (80.01)	5.75 (146.05)	8	.375-24	.79 (20.06)	—
700	5.00 (127.00)	7.125/7.123 (180.97/180.92)	4.88 (123.82)	.06 x 45° (1.58 x 45°)	3.74 (95.0) 4.00 (101.60)	6.250 (158.75)	8†	.375-24	.75 (19.05)	—
750	6.00 (152.4)	8.750/8.748 (222.25/222.20)	5.88 (149.22)	.06 x 45° (1.58 x 45°)	4.13 (104.90)	7.00 (177.80)	8*	.500-20	1.00 (25.40)	—
800	6.00 (152.4)	10.000/9.998 (254.00/253.95)	5.88 (149.22)	.06 x 45° (1.58 x 45°)	5.12 (130.05)	8.94 (227.01)	8 @ 45°	.500-20	1.00 (25.40)	1.25 (31.75)

**Notes:**

† Six holes equally spaced at 60° plus two extra holes at 180°. Six hardened mounting screws should be used.

### Bore sizes and keyseats\*\*\*\*

inches (mm)

Size	Bore Size	Keyseat	Bore Range	
			Min.	Max.
400	.500 (12.70)	1/8 x 1/16 (3.18 x 1.57)	.437 (11.10)	.875 (22.22)
	18 mm .875 (22.22)	6 x 2.8mm*** 3/16 x 1/16 (4.75 x 1.57)		
	1.000 (25.40)	1/4 x 1/8 (6.35 x 3.18)		
500	30mm 1.250 (31.75)	10 x 3.3mm*** 1/4 x 1/8 (6.35 x 3.18)	.750 (19.05)	1.312 (33.32)
	1.312 (33.32)	1/4 x 3/32 (6.35 x 2.29)		
	1.250 (31.75)	1/4 x 1/8 (6.35 x 3.18)		
	1.500 (38.10)	3/8 x 3/16 (9.52 x 4.75)		
600	40mm 50mm 2.000 (50.80)	12 x 3.3mm*** 14 x 3.8mm*** 3/8 x 1/8 (9.52 x 3.18)	.937 (23.80)	2.000* (50.80)
	2.000 (50.80)	1/2 x 1/4 (12.70 x 6.35)		
	2.500 (63.50)	5/8 x 1/8 (15.87 x 3.18)		
650	1.937 (49.20)	1/2 x 1/4 (12.70 x 6.35)	1.69 (42.85)	2.500 (63.5)
	50mm 2.500 (63.50)	14 x 3.8mm 5/8 x 5/16 (15.87 x 7.93)		
	2.937 (74.60)	5/8 x 1/8 (15.87 x 3.18)		
	2.500 (63.50)	5/8 x 5/16 (15.87 x 7.94)		
700	2.937 (74.60)	3/4 x 3/8 (19.05 x 9.52)	1.875 (47.62)	2.937** (74.60)
	3.250 (82.55)	3/4 x 1/4 (19.05 x 6.35)		
	3.250 (82.55)	3/4 x 3/8 (19.05 x 9.52)		
750	3.500 (88.90)	7/8 x 7/16 (22.23 x 11.11)	2.250 (57.15)	3.437 (87.30)
	90mm 3.937 (100.00)	25 x 5.4mm*** 1 x 1/2 (25.40 x 12.70)		
	4.437 (112.70)	1 x 1/4 (25.40 x 6.35)		
	3.250 (82.55)	3/4 x 3/8 (19.05 x 9.52)		
800	3.500 (88.90)	7/8 x 7/16 (22.23 x 11.11)	2.625 (66.67)	4.437 (112.70)
	90mm 3.937 (100.00)	25 x 5.4mm*** 1 x 1/2 (25.40 x 12.70)		
	4.437 (112.70)	1 x 1/4 (25.40 x 6.35)		

\* 1/2 x 1/8 keyway.

\*\* 3/4 x 1/4 keyway.

\*\*\* Contact Formsprag for keyseat information.

\*\*\*\* For Bore Sizes/Shaft Tolerances, see page 128.

† The "E" dimension is larger for this bore size.

# General Purpose Clutches

## FSA

### Overrunning, Indexing Ball Bearing Supported, Sprag Clutches

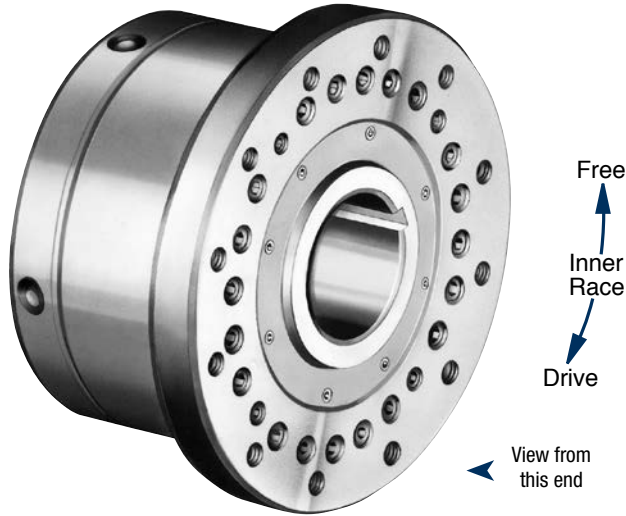

Right Hand rotation shown. (Left Hand opposite.)  
Specify direction of rotation when ordering.

FSA model clutches are designed for low speed overrunning and indexing applications in the torque range from 38,000 to 500,000 lb.ft. FSA clutches are oil lubricated and equipped with lip-type seals.

Formchrome<sup>®</sup> sprags (used in model 1051 only) and “Free-action” retainers are incorporated for maximum performance and service life. These clutches mount on a through shaft, with the inner race driven by a key. They are designed with a special flange as the mounting surface for couplings for primary shaft to shaft inline applications. The ground O.D. of this flange is concentric with the bore. Tapped holes are provided for securing parts to the clutch. All new applications must be reviewed by Formsprag Application Engineering Department for correct bearing support. Refer to Shaft/Bore Tolerance chart for mounting data, page 128.

Standard keys are supplied by Formsprag at no additional charge.

### Oil Lubricated Clutch

FSA-1051 through 5000 clutches are shipped from the factory with Mobil DTE Heavy Medium oil.

### Grease Lubricated Clutch

FSA-1051 through 5000 clutches are shipped from the factory packed with Shell Alvania #1 grease.

For further information see *Installation and Maintenance Bulletin No. A-3032, P--222-20.*

### Typical Mounting Arrangement

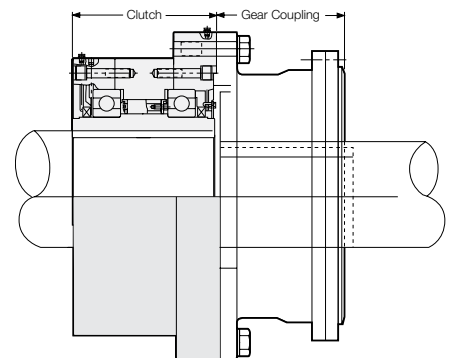

The Model FSA clutches must be axially restrained, see accessories page 122 for set collars, restraint keys and OSHA covers, etc. All fasteners are recommended to be grade 8 bolts.

### Specifications

Size	Torque Capacity lb.ft. (Nm)	Overrunning Speed Max. RPM		Resistance after run-in lb.ft. (Nm)	Lubrication Oil qt (L)	Shipping Weight lb. (kg)
		Inner Race	Outer Race			
1051	38,000 (51680)	400	50	12.0 (16.3)	1.1 (1.07)	433 (196)
1250	47,000 (63920)	170	40	15.0 (203)	2.1 (2.0)	605 (274)
1300	69,000 (93840)	140	35	28 (38.0)	2.4 (2.28)	758 (344)
1375	110,000 (149600)	130	30	32 (43.4)	2.8 (2.66)	996 (452)
2000	200,000 (272000)	100	25	80 (108.5)	3.3 (3.1)	1797 (815)
2400	245,000 (333200)	85	20	100 (135.6)	3.9 (3.7)	2637 (1196)
3500	350,000 (476000)	80	20	120 (162.7)	12 (11.4)	5139 (2331)
5000	500,000 (680000)	75	20	125 (169.5)	11 (10.4)	5389 (2444)

#### Notes:

Check key and shaft stress before making final clutch selection since this may determine the maximum allowable drive torque capacity.

On Models 750 through 5000, Formsprag may elect to supply a stepped key in the event of keyseat distortion during heat treat of inner race.

Specify direction of rotation when ordering.

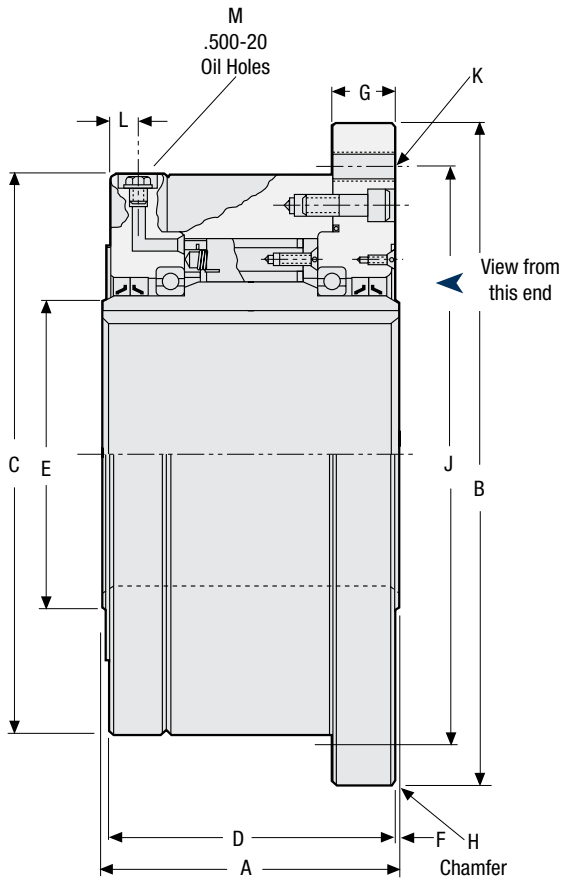

**Bore sizes and keyseats\*\*† inches (mm)**  
(Metric bore also available)

Size	Bore Size	Keyseat	Bore Range	
			Min.	Max.
1051	5.000 to 6.000 (127.00 to 152.40)	1.250 x .63 (31.75 x 15.88)	4.937 (125.40)	7.000 (177.80)
	6.016 to 6.625 (152.81 to 168.28)	1.500 x .63 (38.10 x 15.88)		
	6.641 to 6.875 (168.68 to 174.63)	1.500 x .50 (38.10 x 12.70)		
	6.891 to 7.000 (175.03 to 177.80)	1.500 x .44 (38.10 x 11.10)		
1250	7.500 to 7.937 (190.50 to 201.60)	1.750 x .88 (44.45 x 22.22)	6.750 (171.45)	9.000 (228.60)
	8.000 to 8.250 (203.20 to 209.55)	1.750 x .63 (44.45 x 15.87)		
	8.312 to 9.000 (211.12 to 228.60)	1.500 x .50 (38.10 x 12.70)		
1300	8.000 to 9.250 (203.20 to 234.95)	1.750 x .88 (44.45 x 22.22)	7.937 (201.60)	10.000 (254.00)
	9.312 to 10.000 (236.52 to 254.00)	1.500 x .50 (38.10 x 12.70)		
1375	9.000 to 10.250 (228.60 to 260.35)	1.750 x .88 (44.45 x 22.22)	8.937 (227.00)	11.000 (279.40)
	10.312 to 11.000 (261.92 to 279.40)	2.000 x .75 (50.80 x 19.05)		
2000	11.000 to 12.000 (279.40 to 304.80)	2.500 x 1.25 (63.50 x 31.75)	10.937 (277.80)	13.250 (336.55)
	12.063 to 13.250 (306.40 to 336.55)	2.500 x 1.00 (63.50 x 25.40)		
2400	13.250 to 15.000 (336.55 to 381.00)	2.500 x 1.25 (63.50 x 31.75)	13.000 (330.20)	15.500 (393.70)
	15.063 to 15.500 (382.60 to 393.70)	2.500 x 1.00 (63.50 x 25.40)		
3500	13.500 to 13.750 (342.90 to 349.25)	2.500 x 1.25 (63.50 x 31.75)	13.437 (341.30)	20.000 (508.00)
	14.000 to 18.000 (355.60 to 457.20)	3.000 x 1.50 (76.20 x 38.10)		
	20.000 (508.00)	3.000 x 1.25 (76.20 x 31.75)		
5000	13.500 to 13.750 (342.90 to 349.25)	2.500 x 1.25 (63.50 x 31.75)	13.437 (341.30)	20.000 (508.00)
	14.000 to 18.000 (355.60 to 457.20)	3.000 x 1.50 (76.20 x 38.10)		
	20.000 (508.00)	3.000 x 1.25 (76.20 x 31.75)		

\*\* For finished dimensions of keys supplied with the clutch, contact Formspag.

† For Bore Sizes/Shaft Tolerances, see page 128.

### Dimensions inches (mm)

Size	A	B	C	D	E	F	G	H	J	K			L	M
										Number	Thread	Depth		
1051	9.63 (244.47)	19.500/19.497 (495.30/495.22)	15.00 (381.00)	9.50 (241.30)	8.63 (219.07)	.06 (1.58)	1.50 (38.10)	.13 x 45° (3.17 x 45°)	16.88 (428.62)	16 @ 22.5°	.875-9	1.50 (38.10)	3.63 (92.07)	4 @ 90°
1250	10.25 (260.35)	23.000/22.997 (584.20/584.12)	19.50 (495.30)	10.13 (257.30)	10.65 (270.51)	.06 (1.58)	2.16 (54.86)	.13 x 45° (3.17 x 45°)	20.00 (508.00)	12 @ 30°	1.000-8	2.16 (54.86)	1.00 (25.40)	4 @ 90°
1300	10.25 (260.35)	25.750/25.747 (654.06/653.97)	21.00 (533.40)	9.97 (253.24)	11.65 (295.91)	.22 (5.59)	2.16 (54.86)	.13 x 45° (3.17 x 45°)	22.00 (558.80)	12 @ 30°	1.250-7	2.16 (54.86)	1.00 (25.40)	4 @ 90°
1375	11.00 (279.40)	28.125/28.122 (714.37/714.30)	23.50 (596.90)	9.98 (253.49)	13.45 (341.63)	.43 (10.92)	2.16 (54.86)	.13 x 45° (3.17 x 45°)	24.38 (619.12)	12 @ 30°	1.250-7	2.16 (54.86)	1.00 (25.40)	4 @ 90°
2000	15.25 (387.40)	35.75 (908.05)	35.75 (908.05)	15.62 (396.75)	—	—	4.24 (107.70)	.13 x 45° (3.17 x 45°)	32.25 (819.15)	18 @ 20°	1.250-7	2.00 (50.80)	1.00 (25.40)	4 @ 90°
2400	14.68 (372.87)	36.00 (914.40)	36.00 (914.40)	15.50 (393.70)	—	—	4.42 (112.27)	.13 x 45° (3.17 x 45°)	30.00 (762.00)	18 @ 20°	1.250-7	2.00 (50.80)	1.00 (25.40)	6 @ 60°
3500	18.00 (457.20)	44.50 (1130.30)	37.75 (958.85)	15.50 (393.70)	24.75 (628.65)	1.25 (31.75)	2.38 (60.45)	.19 x 45° (4.75 x 45°)	40.00 (1016.00)	30 @ 12°	1.531* (388.89*)	3.00 (76.20)	1.13 (28.70)	6 @ 60°
5000	18.00 (457.20)	44.50 (1130.30)	37.75 (958.85)	15.50 (393.70)	24.75 (628.65)	1.25 (31.75)	2.38 (60.45)	.19 x 45° (4.75 x 45°)	40.00 (1016.00)	30 @ 12°	1.531* (38.89*)	3.00 (76.20)	1.13 (28.70)	6 @ 60°

\* Drilled hole only.

# General Purpose Clutches

## FS 02, 04, 05

### Overrunning, Indexing, Backstopping Sleeve Bearing Supported, Sprag Clutches

These small clutches are ideal for use in all types of small machines and precision instruments and may be used for overrunning, indexing and backstopping applications. They are sleeve bearing supported clutches. Typical mounting arrangement for FS Series clutches is shown below.

FS 02 through 05 clutches are shipped from the factory lubricated for life with Fiske Brothers Lubriplate Low-Temp grease.

For further information, see *Installation and Maintenance Bulletin A-3003, P-222-16 (FS-02 and FS-04) or No. 2221, P-222-13 (FS-05)*.

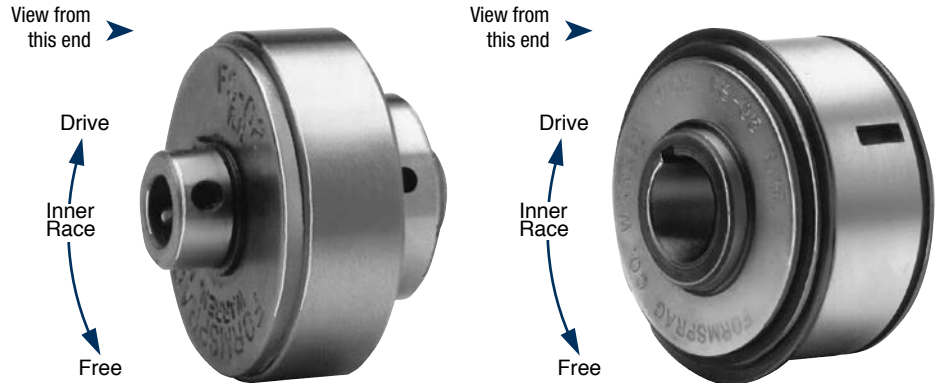

Right Hand rotation shown. (Left Hand opposite).  
Specify direction of rotation when ordering.

### Model FS-02, FS-04

Models FS-02 and FS-04 are secured to the Shaft by a roll pin provided with the clutch. Both the hub and the O.D. of the outer race are ground to close limits and may be used to mount attaching parts.

### Model FS-05

Model FS-05 is driven from the shaft by a .125" key. Parts should be mounted on the ground O.D. of the clutch. Snap rings and Woodruff key are provided.

### Specifications

Size	Torque Capacity lb.ft. (Nm)	Overrunning Speed Max. RPM		Resistance after run-in lb.ft. (Nm)	Lubrication	Shipping Weight lb. (kg)
		Inner Race	Outer Race			
02	4.5 (6)	3,450	2,400	.02 (.027)	Grease	.187 (.08)
04	17 (23)	2,800	2,400	.02 (.027)	Grease	.312 (.14)
05	30 (41)	1,800	900	.05 (.067)	Grease	.812 (.37)

#### Notes:

Check key and shaft stress before making final clutch selection since this may determine the maximum allowable drive torque capacity.

Specify direction of rotation when ordering.

### Typical Mounting Arrangements

#### FS-02

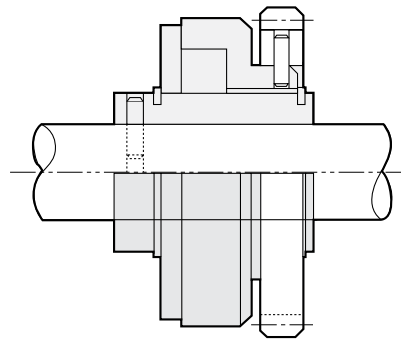

The Model FS 02 and 04 must be axially restrained by a Roll Pin (supplied) through the shaft.

#### FS-05

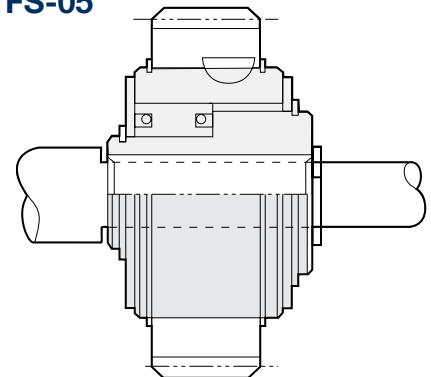

The Model FS 05 must be axially restrained by customer supplied snap ring, set collar, spacer, etc.



### FS-02 and FS-04

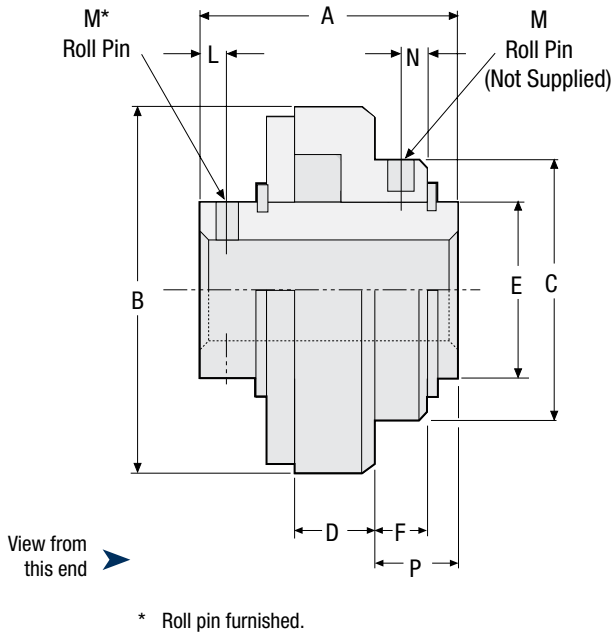

### FS-05

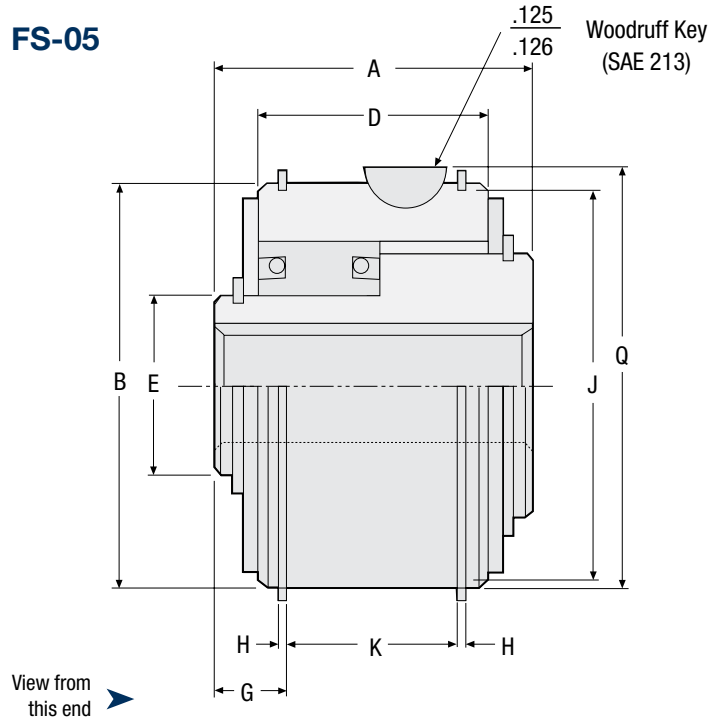

### Bore sizes and keyseats\*\* inches (mm)

(Metric bore also available)

Size	Bore Size	Keyseat	Bore Range	
			Min.	Max.
02	.250 (6.35)	roll pin	.250 (6.35)	.250 (6.35)
		roll pin		
04	.375/.500 (9.53/12.70)	roll pin	.375 (.953)	.625 (15.88)
		roll pin		
05	.625 (15.88)	1/8 x 1/16 (3.18 x 1.59)	.500 (12.70)	.630 (16.0)

\*\* For Bore Sizes/Shaft Tolerances, see page 128.

### Dimensions inches (mm)

Size	A	B	C	D	E	F	G	H	J	K (Max.)	L	M	N	P	Q (Max.)
02	1.06 (27.00)	1.250/1.249 (31.75/31.71)	.750/.749 (19.05/19.02)	.390 (9.9)	.429 (10.9)	.250 (6.35)	—	—	—	—	.109 (2.76)	.093 (2.36)	.140 (3.56)	.343 (8.71)	—
04	1.13 (28.60)	1.626/1.624 (41.28/41.24)	1.125/1.124 (28.58/28.55)	.375 (9.5)	.796 (20.2)	.250 (6.35)	—	—	—	—	.125 (3.18)	.125 (3.18)	.156 (3.96)	.359 (9.12)	—
05	1.40 (35.70)	1.937/1.936 (49.20/49.17)	—	1.000 (25.4)	.953 (24.2)	—	.284/.388 (7.22/9.85)	.056/.076 (1.42/1.93)	1.866/1.856 (47.40/47.14)	.750 Max. (19.05 Max.)	—	—	—	—	2.015 Max. (51.18 Max.)

# General Purpose Clutches

## FSR

### Overrunning, Indexing, Backstopping Sleeve Bearing Supported, Sprag Clutches

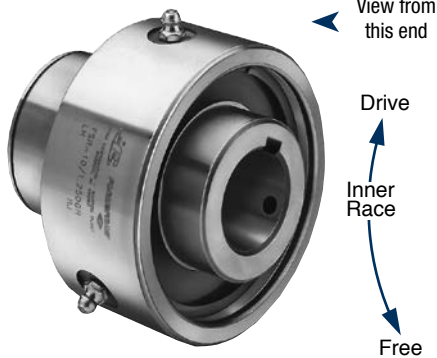

Right Hand rotation shown.  
(Left Hand opposite.)

Specify direction of rotation when ordering.

There are eight sleeve-bearing clutch models suitable for general purpose applications—overrunning, indexing and backstopping. To provide maximum life and resistance to wear, all FSR model clutches incorporate Formchrome® sprags; models FSR-5 thru FSR-16 have the Formsprag “Free-action” sprag retainer. A keyseat and snap-ring groove

are provided to secure attached parts to the hub, which is ground as a mounting surface. Oil lubricated models have a Buna-N oil seal at each end of the clutch which provides positive lubricant sealing. They can be removed for free lubricant flow if clutch is operated in an oil bath.

The shaft must extend through the full length of the clutch and must be held to recommended limits because the sleeve-bearing in the outer race rides on the shaft.

The keyseat in the shaft must not extend into the sleeve-bearing area of the clutch. Refer to Bore Sizes/Shaft Tolerances chart on page 128.

For vertical mounting, contact Application Engineering.

FSR-3 through 16 clutches are shipped from the factory packed with Fiske Brothers Lubriplate Low-Temp grease.\*

FSR-3 are grease lubricated for life.

Oil lubricated clutches are shipped without lubrication and require filling before use.

For further information see *Installation and Maintenance Bulletin No. 2217, P-222-8.*

### Typical Mounting Arrangement

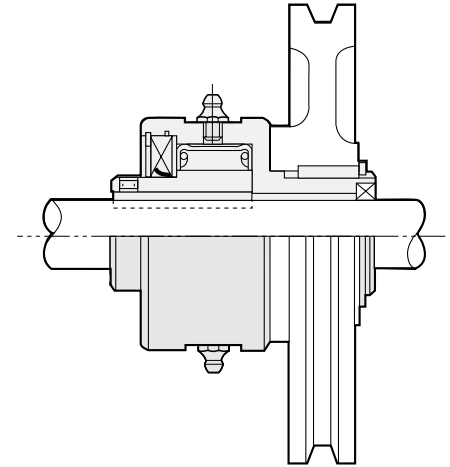

The Model FSR-3 is secured to the shaft by a .187 roll pin (furnished). Models FSR-5 and up are secured to the shaft by two set screws also furnished.

### Specifications

Size	Torque Capacity lb.ft. (Nm)	Overrunning Speed Max. RPM		Resistance after run-in lb.ft. (Nm)	Keyseat in Hub (W) (output) in. (mm)	Lubrication (Grease) Required* oz (ml)	Shipping Weight lb. (kg)
		Inner Race	Outer Race				
3	40 (55)	1,950	900	.20 (.27)	1/8 x 1/16 (3.18 x 1.58)	Grease	1 (0.5)
5	110 (150)	1,950	900	.50 (.68)	3/16 x 3/32 (4.76 x 2.38)	.25 (7.4)	2 (0.9)
6	300 (408)	1,950	750	1.68 (2.28)	3/16 x 3/32 (4.76 x 2.38)	.375 (11.1)	3 (1.4)
8	450 (612)	1,650	600	2.80 (3.80)	1/4 x 1/8 (6.35 x 3.17)	.5 (14.8)	5 (2.3)
10	675 (918)	1,250	350	3.50 (4.75)	5/16 x 5/32 (7.93 x 3.96)	.5 (14.8)	6 (2.7)
12	1,350 (1836)	1,150	350	5.84 (7.90)	3/8 x 3/16 (9.52 x 4.76)	.75 (22.2)	9 (4.0)
14	1,600 (2176)	950	250	6.87 (9.30)	7/16 x 7/32 (11.11 x 5.54)	1 (29.6)	15 (6.8)
16	1,800 (2448)	950	250	6.87 (9.30)	1/2 x 1/4 (12.70 x 6.35)	1 (29.6)	15 (6.8)

#### Notes:

Check key and shaft stress before making final clutch selection since this may determine the maximum allowable drive torque capacity.

Specify direction of rotation when ordering.

\* Oil lubricated designs are also available. Oil lubricated clutches are shipped without lubrication and require filling before use.

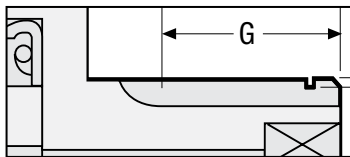
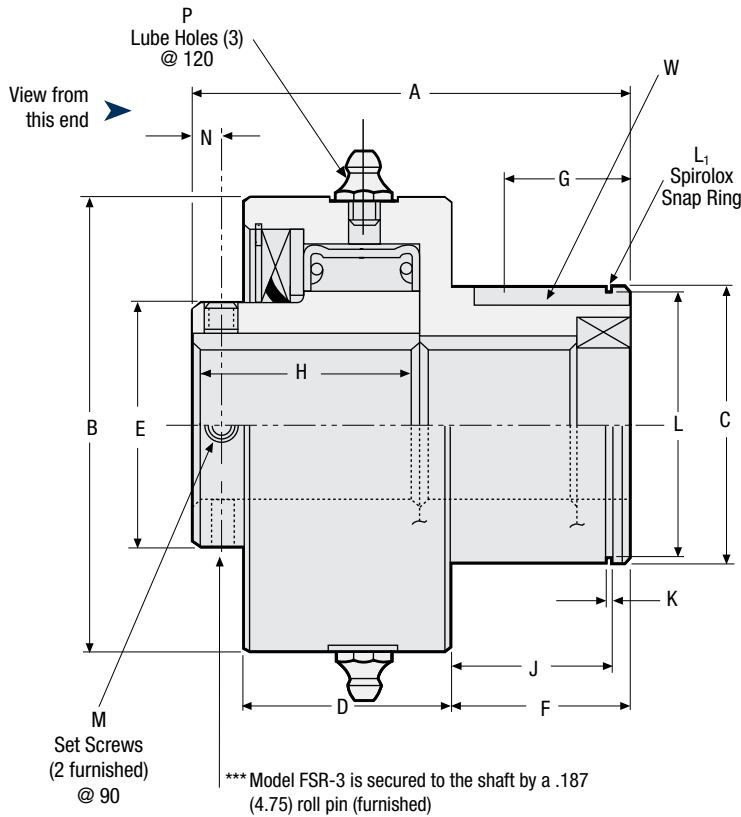

Optional Woodruff key seat in outer race is available

### Bore sizes and keyseats<sup>†</sup> inches (mm) (Metric bore also available)

Size	Bore Size	Keyseat	Bore Range	
			Min.	Max.
3	.375/.500 (9.52/12.70)	***	.375 (9.52)	.500 (12.70)
	.500 (12.70)	1/8 x 1/16 (3.18 x 1.59)	.500 (12.70)	.687 (17.45)
5	.625 (15.88)	3/16 x 3/32 (4.76 x 2.38)		
	.750 (19.05)	3/16 x 3/32 (4.75 x 2.38)	.750 (19.05)	.875 (22.22)
6	20mm	6 x 2.8mm <sup>†</sup>		
	.875 (22.22)	1/4 x 1/8 (6.35 x 3.18)		
8	25mm	8 x 3.8mm <sup>†</sup>	.688 (17.46)	1.125 (28.57)
	1.000 (25.40)	1/4 x 1/8 (6.35 x 3.18)		
10	1.125 (28.58)	5/16 x 5/32** (7.93 x 3.96)		
	30mm	8 x 3.8mm <sup>†</sup>	.875 (22.22)	1.375 (34.92)
12	1.250 (31.75)	5/16 x 5/32 (7.93 x 3.96)		
	1.375 (34.93)	5/16 x 5/32 (7.93 x 3.96)	1.125 (28.57)	1.625 (41.27)
14	1.500 (38.10)	3/8 x 3/16 (9.52 x 4.76)		
	40mm	12 x 3.3mm <sup>†</sup>		
16	1.625 (41.27)	7/16 x 7/32 (11.11 x 5.54)	1.375 (34.92)	1.875 (47.62)
	1.750 (44.45)	7/16 x 7/32 (11.11 x 5.54)		
16	45mm	12 x 3.3mm <sup>†</sup>		
	1.875 (47.62)	1/2 x 1/4 (12.70 x 6.35)	1.500 (38.10)	2.187 (55.55)
16	50mm	14 x 3.8mm <sup>†</sup>		
	2.000 (50.80)	1/2 x 1/4 (12.70 x 6.35)		

\*\* 250 x .13 also available

<sup>†</sup> For Bore Sizes/Shaft Tolerances, see page 128.

### Dimensions inches (mm)

Size	A	B	C	D	E	F	G	H	J	K	L	L1*	M	N	P
3	1.88 (47.62)	1.63 (41.27)	.875/.874 (22.23/22.20)	.69 (17.46)	.70 (17.78)	.81 (20.64)	.500 (12.70)	.94 (33.32)	.715/.720 (18.16/18.29)	.036/.056 (.91/1.42)	.841/.835 (21.36/21.21)	RS 87	—	.22 (5.54)	—
5	2.75 (69.85)	2.00 (50.80)	1.250/1.249 (31.75/31.72)	1.25 (31.75)	1.00 (25.40)	1.00 (25.40)	.562 (14.27)	1.63 (41.27)	.900/.905 (22.86/22.99)	.048/.068 (1.22/1.73)	1.206/1.198 (30.63/30.43)	RS 125	#8-36	.25 (6.35)	#10-32
6	3.19 (80.95)	2.88 (73.00)	1.375/1.374 (34.93/34.90)	1.56 (39.67)	1.38 (34.92)	1.31 (33.32)	.937 (23.80)	1.69 (42.85)	1.215/1.220 (30.86/30.99)	.048/.068 (1.22/1.73)	1.327/1.319 (33.70/33.50)	RS 137	#10-32	.18 (4.75)	.250-28
8	3.56 (90.50)	3.25 (82.55)	1.750/1.749 (44.45/44.42)	1.75 (44.45)	1.62 (41.27)	1.44 (36.50)	1.00 (25.40)	1.88 (47.62)	1.315/1.320 (33.40/33.53)	.056/.076 (1.42/1.93)	1.696/1.686 (43.08/42.82)	RS 175	.250-28	.25 (6.35)	.250-28
10	3.50 (88.90)	3.75 (95.25)	2.250/2.249 (57.15/57.12)	1.75 (44.45)	2.03 (51.59)	1.44 (36.50)	.94 (23.80)	1.81 (46.02)	1.340/1.345 (34.04/34.16)	.056/.076 (1.42/1.93)	2.182/2.170 (55.42/55.12)	RS 225	.250-28	.25 (6.35)	.250-28
12	3.88 (98.42)	4.44 (112.70)	2.500/2.499 (63.50/63.47)	1.94 (49.20)	2.38 (60.32)	1.44 (36.50)	1.19 (30.22)	2.13 (53.97)	1.311/1.321 (33.30/33.55)	.120/.130 (3.05/3.30)	2.391/2.379 (60.73/60.43)	RST-250	.312-24	.31 (7.92)	.250-28
14	4.38 (111.12)	5.50 (139.70)	2.875/2.874 (73.03/73.00)	2.19 (55.56)	3.00 (76.20)	1.75 (44.45)	1.34 (34.04)	2.25 (57.15)	1.625/1.630 (41.27/41.40)	.056/.076 (1.42/1.93)	2.787/2.775 (70.79/70.48)	RS 287	.312-24	.31 (7.92)	.250-28
16	4.38 (111.12)	5.50 (139.70)	3.250/3.249 (82.55/82.52)	2.19 (55.56)	3.00 (76.20)	1.75 (44.45)	1.44 (36.58)	2.25 (57.15)	1.650/1.655 (41.91/42.04)	.068/.088 (1.72/2.23)	3.156/3.144 (80.16/79.86)	RS 325	.312-24	.31 (7.92)	.250-28

\* Spirolox snap ring not included.

<sup>†</sup> Contact Formsprag for keyseat information.

# General Purpose Clutches

## CSK, CSK..2RS

Overrunning, Indexing, Backstopping Bearing Envelope (62 Series) Design, Sprag Clutches



### CSK

Type CSK is a sprag type clutch integrated into a 62 Series ball bearing (except sizes 8 and 40). It is bearing supported, shipped grease lubricated and protected against dust larger than .012" (.3mm) diameter. The use of additional "nylos" type seals is recommended especially when the working temperature exceeds 122°F (50°C).

Oil bath lubrication is also possible if the original grease is first flushed out using a suitable solvent.

Torque transmission is ensured by a press fit assembly into a rigid outer housing with a recommended N6 tolerance and onto a shaft with a recommended n6 tolerance. The resulting housing and shaft diameters must be checked to ensure that the bearing has adequate radial clearances. The initial bearing radial clearance is set at C5, and is reduced if using the press fit as specified.

One race may be glued. If both races are to be glued, performance will be reduced or a C3 bearing clearance will be necessary.

Operating temperature: 21 to 140°F (-6 to 60°C). Special grease available for operating temperatures: -40 to 212°F (-40 to 100°C)

### CSK..2RS

CSK..2RS clutches are .197" (5mm) wider than a standard 62 Series bearing, as they are equipped with lip seals for washdown applications.

### Specifications

Model	Size	Bearing Series	Torque Capacity** lb.ft. (Nm)	Max. Overrunning Speed RPM	Resistance after run-in lb.in. (Ncm)	Lubrication	Shipping Weight lb. (kg)
CSK	8		2.6 (3.5)	15,000	0.04 (0.5)	Grease	0.03 (0.015)
	12	6201	8.8 (12)	10,000	0.06 (0.7)	Grease	0.09 (0.04)
	15	6202	14.7 (20)	8,400	0.08 (0.9)	Grease	0.13 (0.06)
	17	6203	30 (40)	7,350	0.09 (1.1)	Grease	0.15 (0.07)
	20	6204	50 (68)	6,000	0.12 (1.3)	Grease	0.24 (0.11)
	25	6205	77 (105)	5,200	0.18 (2)	Grease	0.31 (0.14)
	30	6206	133 (180)	4,200	0.39 (4.4)	Grease	0.46 (0.21)
	35	6207	177 (240)	3,600	0.51 (5.8)	Grease	0.66 (0.3)
	40		284 (385)	3,000	0.62 (7)	Grease	1.10 (0.5)
	CSK..2RS	8*		2.6 (3.5)	15,000	0.07 (0.8)	Grease
12			8.8 (12)	10,000	0.27 (3)	Grease	0.11 (0.05)
15			14.7 (20)	8,400	0.35 (4)	Grease	0.15 (0.07)
17			30 (40)	7,350	0.50 (5.6)	Grease	0.20 (0.09)
20			50 (68)	6,000	0.53 (6)	Grease	0.32 (0.145)
25			77 (105)	5,200	0.53 (6)	Grease	0.39 (0.175)
30			133 (180)	4,200	0.66 (7.5)	Grease	0.60 (0.27)
35			177 (240)	3,600	0.73 (8.2)	Grease	0.88 (0.4)
40			284 (385)	3,000	0.89 (10)	Grease	1.32 (0.6)

\* Only one lip seal on ball bearing side.

\*\* Clutch torque ratings are based upon 1 million load cycles, standard for the North American market.

# General Purpose Clutches

## CSK, CSK..2RS

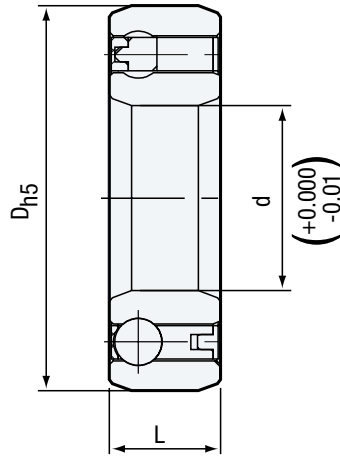

### Dimensions inches (mm)

Model	Size	D <sub>h5</sub> in. (mm)	L in. (mm)	Bearing Loads	
				Dynamic lb. (kN)	Static lb. (kN)
CSK	8	0.87 (22)	0.35 (9)	738 (3.28)	193.5 (0.86)
	12	1.26 (32)	0.39 (10)	1372.5 (6.1)	623.25 (2.77)
	15	1.38 (35)	0.43 (11)	1665 (7.4)	769.5 (3.42)
	17	1.57 (40)	0.47 (12)	1777.5 (7.9)	855 (3.8)
	20	1.85 (47)	0.55 (14)	2115 (9.4)	1003.5 (4.46)
	25	2.05 (52)	0.59 (15)	2407.5 (10.7)	1228.5 (5.46)
	30	2.44 (62)	0.63 (16)	2632.5 (11.7)	1451.25 (6.45)
	35	2.83 (72)	0.67 (17)	2835 (12.6)	1638 (7.28)
	40	3.15 (80)	0.87 (22)	3496.5 (15.54)	2756.25 (12.25)
	CSK..2RS	8*	0.87 (22)	0.35 (9)	738 (3.28)
12		1.26 (32)	0.55 (14)	1372.5 (6.1)	623.25 (2.77)
15		1.38 (35)	0.63 (16)	1665 (7.4)	769.5 (3.42)
17		1.57 (40)	0.67 (17)	1777.5 (7.9)	855 (3.8)
20		1.85 (47)	0.75 (19)	2115 (9.4)	1003.5 (4.46)
25		2.05 (52)	0.79 (20)	2407.5 (10.7)	1228.5 (5.46)
30		2.44 (62)	0.83 (21)	2632.5 (11.7)	1451.25 (6.45)
35		2.83 (72)	0.87 (22)	2835 (12.6)	1638 (7.28)
40		3.15 (80)	1.06 (27)	3496.5 (15.54)	2756.25 (12.25)

\* Only one lip seal on ball bearing side.

### Bore sizes and keyseats inches (mm)

Size	d Bore Size	Keyseat
8	0.31 (8)	None
12	0.47 (12)	None
15	0.59 (15)	None
17	0.67 (17)	None
20	0.79 (20)	None
25	0.98 (25)	None
30	1.18 (30)	None
35	1.38 (35)	None
40	1.57 (40)	None

### Typical Mounting Arrangement

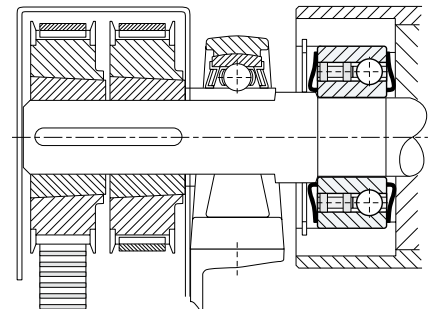

The Model CSK clutches must be mounted with a press fit on both the outer and inner races. The shaft diameter tolerance must be held to a n6. The bore of the housing for the outer race should be a N6 tolerance.

# Overrunning Applications

## CSK..P, CSK..PP

Overrunning, Indexing, Backstopping Bearing Envelope (62 Series) Design, Sprag Clutches

### CSK..P

CSK..P has the same construction and outside dimensions as type CSK, but has a keyway on the inner race.

These clutches can be mounted on a shaft with recommended k6 tolerance and the outer race must be pressed into a rigid housing with a recommended N6 tolerance. The resulting housing and shaft diameters must be checked to ensure that the bearing has adequate radial clearances.

### CSK..PP

CSK..PP features a keyway on both the inner and outer race. The recommended mounting tolerances are k6 on the shaft and K6 in the rigid housing. A h6 tolerance on the shaft or H6 in the housing are also acceptable for a light press fit assembly. Always check to ensure that the bearing has adequate radial clearances.

Operating temperature: 21 to 140°F (-6 to 60°C). Special greases are available for operating temperatures: -40 to 212°F (-40 to 100°C)

### Typical Mounting Arrangement

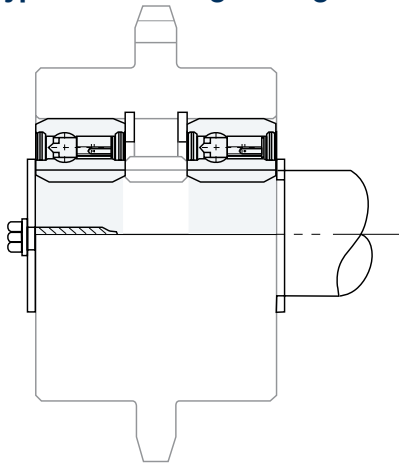

The Model CSK..P clutches must be secured to the shaft by customer supplied snap ring, set collar, spacer, etc. The outer race is secured with a press fit to a N6 tolerance. The Model CSK..PP clutches have a keyseat on both races and must be secured by customer supplied snap ring, set collar, spacer, etc.



### Specifications

Model	Size	Bearing Series	Torque Capacity** lb.ft. (Nm)	Max. Overrunning Speed RPM	Resistance after run-in lb.in. (Ncm)	Lubrication	Shipping Weight lb. (kg)
CSK..P/CSK..PP	12*	6201	8.9 (12)	10,000	0.06 (0.7)	Grease	0.08 (0.04)
	15	6202	14.7 (20)	8,400	0.08 (0.9)	Grease	0.13 (0.06)
	17	6203	30 (40)	7,350	0.09 (1.1)	Grease	0.15 (0.07)
	20	6204	50 (68)	6,000	0.12 (1.3)	Grease	0.24 (0.11)
	25	6205	77 (105)	5,200	0.18 (2)	Grease	0.31 (0.14)
	30	6206	133 (180)	4,200	0.39 (4.4)	Grease	0.46 (0.21)
	35	6207	177 (240)	3,600	0.51 (5.8)	Grease	0.66 (0.3)
	40	—	284 (385)	3,000	0.62 (7)	Grease	1.10 (0.5)
CSK..P-2RS	12	—	8.9 (12)	10,000	0.26 (3)	Grease	0.11 (0.05)
	15	—	14.7 (20)	8,400	0.35 (4)	Grease	0.15 (0.07)
	17	—	30 (40)	7,350	0.49 (5.6)	Grease	0.20 (0.09)
	20	—	50 (68)	6,000	0.53 (6)	Grease	0.33 (0.15)
	25	—	77 (105)	5,200	0.53 (6)	Grease	0.4 (0.18)
	30	—	133 (180)	4,200	0.66 (7.5)	Grease	0.6 (0.27)
	35	—	177 (240)	3,600	0.72 (8.2)	Grease	0.9 (0.4)
	40	—	284 (385)	3,000	0.88 (10)	Grease	1.3 (0.6)
CSK..PP-2RS	30	—	133 (180)	4,200	0.85 (7.5)	Grease	0.6 (0.27)

\* Only available in -P design.

\*\* Clutch torque ratings are based upon 1 million load cycles, standard for the North American Market.

### CSK..P

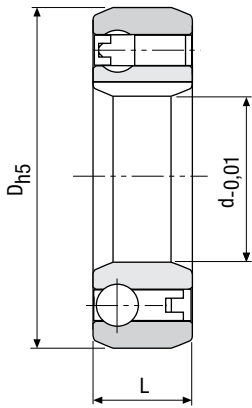

### CSK..PP

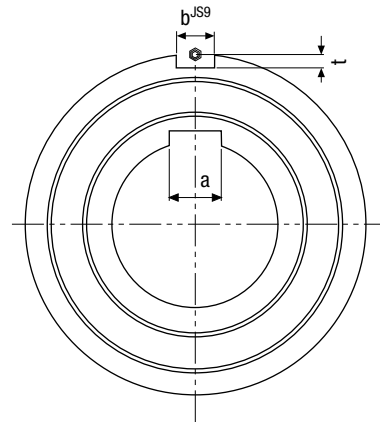
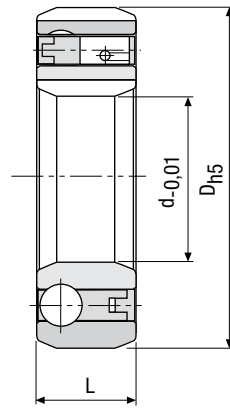

### Dimensions inches (mm)

Size	$D_{h5}$ in. (mm)	L in. (mm)	b in. (mm)	t in. (mm)	Bearing Loads	
					Dynamic lb. (kN)	Static lb. (kN)
12*	1.25 (32)	0.39 (10)	—	—	1,372 (6.1)	623.2 (2.77)
15	1.38 (35)	0.43 (11)	.08 (2)	.02 (0.6)	1,665 (7.4)	769.5 (3.42)
17	1.57 (40)	0.47 (12)	.08 (2)	.04 (1.0)	1,777.5 (7.9)	855 (3.8)
20	1.85 (47)	0.55 (14)	.12 (3)	.06 (1.5)	2,115 (9.4)	1,003.5 (4.46)
25	2.05 (52)	0.59 (15)	.24 (6)	.08 (2.0)	2,407.5 (10.7)	1,228.5 (5.46)
30	2.44 (62)	0.63 (16)	.24 (6)	.08 (2.0)	2,632.5 (11.7)	1,451.25 (6.45)
35	2.83 (72)	0.67 (17)	.31 (8)	.10 (2.5)	2,835 (12.6)	1,638 (7.28)
40	3.15 (80)	0.87 (22)	.39 (10)	.12 (3.0)	3,496.5 (15.54)	2,756.25 (12.25)
12	1.25 (32)	0.55 (14)	—	—	1,372 (6.1)	623.2 (2.77)
15	1.38 (35)	0.62 (16)	—	—	1,665 (7.4)	769.5 (3.42)
17	1.57 (40)	0.67 (17)	—	—	1,777.5 (7.9)	855 (3.8)
20	1.85 (47)	0.75 (19)	—	—	2,115 (9.4)	1,003.5 (4.46)
25	2.04 (52)	0.78 (20)	—	—	2,407.5 (10.7)	1,228.5 (5.46)
30	2.44 (62)	0.82 (21)	—	—	2,632.5 (11.7)	1,451.25 (6.45)
35	2.83 (72)	0.87 (22)	—	—	2,834 (12.6)	1,638 (7.28)
40	3.15 (80)	1.06 (27)	—	—	3,486 (15.5)	2,756 (12.25)

\* Only available in -P design.

### Bore sizes and keyseats inches (mm)

Size	d Bore Size	a Keyseat*
12	0.47 (12)	(4 X 1.8)
15	0.59 (15)	(5 X 1.2)
17	0.67 (17)	(5 X 1.2)
20	0.79 (20)	(6 X 1.6)
25	0.98 (25)	(8 X 2)
30	1.18 (30)	(8 X 2)
35	1.38 (35)	(10 X 2.4)
40	1.57 (40)	(12 X 3.3)

\* For keyseat sizes CSK 15–35 use DIN 6885.3.  
For size 40 use DIN 6885.1 table on page 129.

# General Purpose Clutches

## ASK

### Overrunning, Indexing, Backstopping Bearing Envelope (60 Series) Design, Ramp & Roller Clutches



#### Sealed unit

Model ASK is a ramp & roller type clutch bearing supported by two rows of roller bearings. It is a self contained and dust protected unit, shipped grease lubricated.

Nominal outside envelope dimensions are the same as a 60 Series bearing.

Torque transmission must be accomplished by a press fit on both the inner and outer race. Because of this press fit, the standard radial clearance is C4.

The interference fit tolerances on the clutch envelope, allow for a direct mounting in a standard Series 60 bearing location.

Shaft tolerance should be h6 or j6.

The outer race should be pressed into a rigid housing to K6 tolerance.

Radial bearing load capacities are given in the table.

Model ASK clutches can not accept axial loading. In cases of such loads, thrust bearings must be provided.

#### Specifications

Size	Bearing Series	Torque Capacity lb.ft. (Nm)	Max. Overrunning Speed		Resistance after run-in lb.in. (Ncm)	Lubrication	Shipping Weight lb. (kg)
			Outer Race RPM	Inner Race RPM			
40	6008	53 (72)	3,500	1,400	1.3 (15)	Grease	0.55 (0.25)
50	6010	92 (125)	3,000	1,400	1.7 (20)	Grease	0.75 (0.34)
60	6012	185 (250)	2,500	1,400	2.2 (25)	Grease	1.10 (0.5)

#### Typical Mounting Arrangement

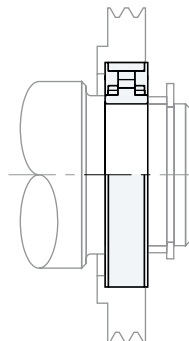

The ASK clutch must be mounted with a press fit on both the outer and inner race. The shaft diameter tolerance must be held to h6 or j6. The bore of the housing for the outer race should be a K6 tolerance.



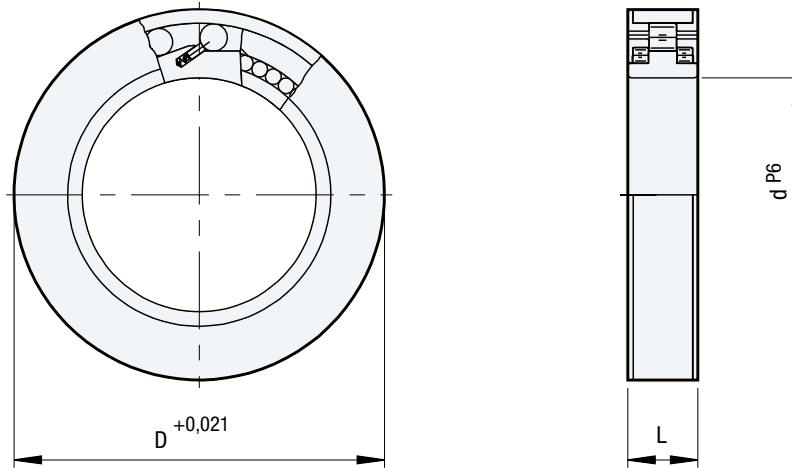

### Dimensions inches (mm)

Size	D in. (mm)	L in. (mm)	Bearing Loads	
			Dynamic lb. (kN)	Static lb. (kN)
40	2.68 (68)	0.59 (15)	3645 (16.2)	4635 (20.6)
50	3.15 (80)	0.63 (16)	4410 (19.6)	5287.5 (23.5)
60	3.74 (95)	0.71 (18)	5692.5 (25.3)	7897.5 (35.1)

### Bore sizes and keyseats inches (mm)

Size	d <sup>P6</sup> Bore Size	Keyseat <sup>(1)</sup>
40	1.57 (40)	None
50	1.97 (50)	None
60	2.36 (60)	None

<sup>(1)</sup> Press fit is required; see Typical Mounting Arrangement, page 30.

# General Purpose Clutches

## GFK

### Overrunning, Indexing, Backstopping Bearing Envelope (59 Series) Design, Sprag Clutches

#### Integrated into 59 Series ball bearing



Model GFK is a sprag type clutch integrated into a 59 Series ball bearing.

This design provides high torque capacity for minimal outside diameter.

It is a bearing supported type, shipped grease lubricated.

Oil bath lubrication is also possible if the original grease is first removed by flushing the clutch with a suitable solvent.

Whatever the lubrication type, seals should be provided, as illustrated below.

Torque transmission must be ensured by a press fit assembly into a rigid outer housing with R6 tolerance, and onto a shaft with p5 tolerance.

The total press fit on the GFK should not exceed the internal clearance for the model as listed in the Internal Clearance Column.

Operating temperature ranges from -4°F to +212°F (-20°C to +100°C). Peaks up to 248°F (+120°C) are acceptable for short periods.

#### Specifications

Size	Bearing Series	Torque Capacity lb.ft. (Nm)	Overrunning Speed Max. RPM		Lubrication	Internal Clearance (mm)	Shipping Weight lb. (kg)
			Inner Race	Outer Race			
20	5904	38 (51)	5,500	4,000	Grease	(.055 to .085)	0.20 (0.09)
25	5905	48 (65)	5,300	3,800	Grease	(.06 to .09)	0.24 (0.11)
30	5906	70 (95)	5,000	3,500	Grease	(.06 to .09)	0.29 (0.13)
35	5907	151 (204)	4,600	3,200	Grease	(.07 to .105)	0.44 (0.20)
40	5908	232 (315)	4,200	3,000	Grease	(.07 to .105)	0.66 (0.30)
45	5909	273 (370)	3,800	2,500	Grease	(.085 to .12)	0.75 (0.34)

#### Typical Mounting Arrangement

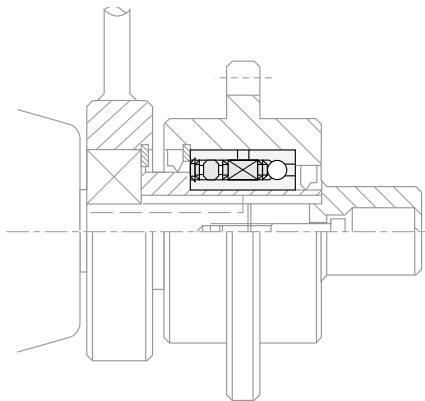

The Model GFK clutch must be mounted with a press fit on both the inner and outer race. The shaft diameter tolerance should be p5 and the bore diameter tolerance for the outer race should be an R6. Seals must be provided to retain the lubricant in this clutch.

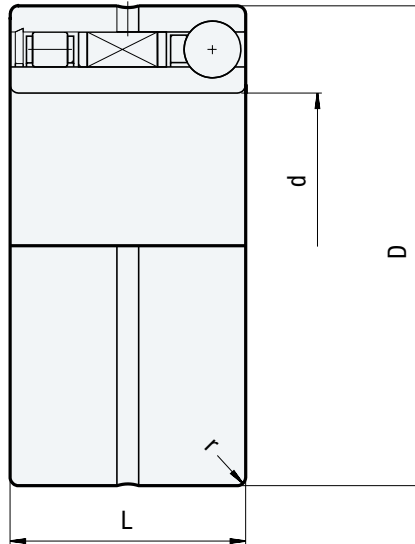

**Dimensions** inches (mm)

Size	Bearing Loads				D in. (mm)	Balls L in. (mm)	r in. (mm)
	Rollers Dynamic lb. (N)	Balls Dynamic lb. (N)	Rollers Static lb. (N)	Static lb. (N)			
20	1260 (5600)	990 (4400)	652.5 (2900)	618.75 (2750)	1.46 (37)	0.91 (23)	0.02 (0.5)
25	1417.5 (6300)	1192.5 (5300)	776.25 (3450)	753.75 (3350)	1.65 (42)	0.91 (23)	0.02 (0.5)
30	1732.5 (7700)	1237.5 (5500)	1035 (4600)	821.25 (3650)	1.85 (47)	0.91 (23)	0.02 (0.5)
35	1845 (8200)	1912.5 (8500)	1170 (5200)	1282.5 (5700)	2.17 (55)	1.06 (27)	0.04 (1)
40	1946.25 (8650)	1867.5 (8300)	1293.75 (5750)	1282.5 (5700)	2.44 (62)	1.18 (30)	0.04 (1)
45	2070 (9200)	2171.25 (9650)	1428.75 (6350)	1620 (7200)	2.68 (68)	1.18 (30)	0.04 (1)

**Bore sizes and keyseats** inches (mm)

Size	d Bore Size	Keyseat <sup>(1)</sup>
20	0.79 (20)	None
25	0.98 (25)	None
30	1.18 (30)	None
35	1.38 (35)	None
40	1.57 (40)	None
45	1.77 (45)	None

<sup>(1)</sup> Press fit is required; see Typical Mounting Arrangement, page 32.

# General Purpose Clutches

## AS

Overrunning, Indexing, Backstopping External Bearing Support Required, Ramp & Roller Clutches



Model AS is a ramp & roller type clutch, non-bearing supported.

Bearings are required to support axial and radial loads. Lubrication and sealing are required.

Nominal outside dimensions are the same as Series 62 ball bearings.

A typical arrangement is to install this type alongside a Series 62 bearing, within the same location tolerances.

The inner race is keyed to the shaft (except for size 6 mm bore).

The outer race has a positive r6 tolerance to give a press fit in a H7 housing.

The outer housing must be strong enough not to expand after assembly.

This design can accept an axial misalignment of inner and outer race of  $\pm S/2$ .

These clutches are oil dipped at the factory but must be filled to the proper level before operation.

This clutch is designed for oil lubrication. For grease lubrication, reduce the maximum overrunning speed to 50% of listed value.

### Specifications

Size	Torque Capacity lb.ft. (Nm)	Overrunning Speed Max. RPM		Resistance after run-in lb.in. (Ncm)	Shipping Weight lb. (kg)
		Inner Race	Outer Race		
6	1.5 (2.1)	5,000	7,500	0.02 (0.18)	0.02 (0.01)
8	3 (3.8)	4,300	6,500	0.02 (0.24)	0.04 (0.02)
10	5 (6.8)	3,500	5,200	0.02 (0.69)	0.07 (0.03)
12	10 (13.0)	3,200	4,800	0.04 (0.48)	0.09 (0.04)
15	10 (14.0)	2,800	4,300	0.06 (0.7)	0.11 (0.05)
20	30 (40.0)	2,200	3,300	0.12 (1.4)	0.26 (0.12)
25	41 (56)	1,900	2,900	0.21 (2.4)	0.31 (0.14)
30	66 (90)	1,600	2,400	0.69 (7.8)	0.49 (0.22)
35	106 (143)	1,300	2,000	0.80 (9)	0.68 (0.31)
40	137 (185)	1,200	1,800	0.89 (10)	0.86 (0.39)
45	161 (218)	1,000	1,600	0.97 (11)	0.97 (0.44)
50	170 (230)	950	1,500	1.20 (13)	1.08 (0.49)
55	227 (308)	800	1,300	1.20 (14)	1.46 (0.66)
60	375 (508)	700	1,100	2.30 (26)	1.79 (0.81)
80	784 (1063)	600	900	5.10 (58)	3.11 (1.41)

### Typical Mounting Arrangement

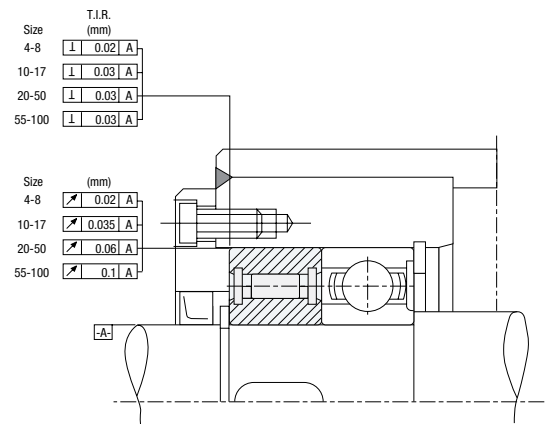

The AS clutch must be mounted adjacent to bearings to provide the concentricity and to support any axial and radial loads. Oil or grease lubrication must be provided along with seals to retain the lubricant.

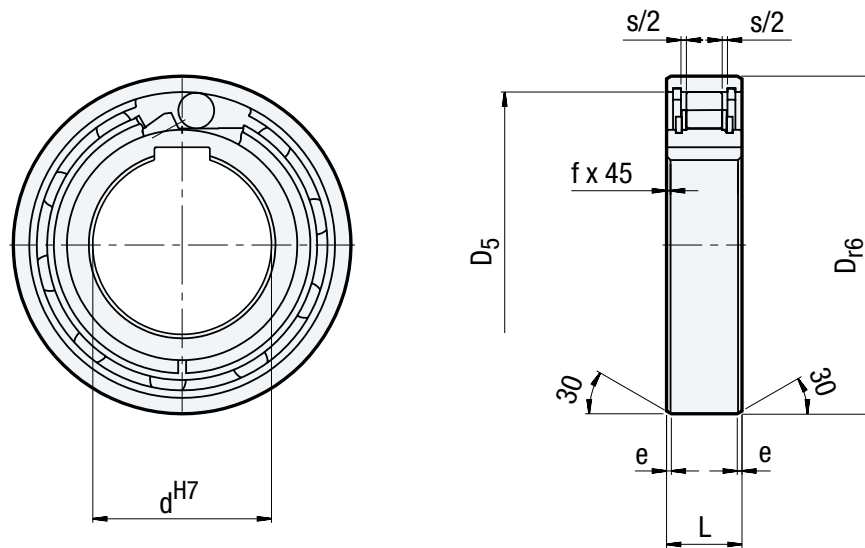

### Dimensions inches (mm)

Size	D <sub>16</sub>	D <sub>5</sub>	L	s	e	f
6	0.75 (19)	0.62 (15.8)	0.24 (6)	0.03 (0.8)	0.02 (0.6)	0.01 (0.3)
8	0.94 (24)	0.79 (20)	0.31 (8)	0.05 (1.3)	0.02 (0.6)	0.02 (0.6)
10	1.18 (30)	1.02 (25.9)	0.35 (9)	0.05 (1.3)	0.02 (0.6)	0.02 (0.6)
12	1.26 (32)	1.10 (28)	0.39 (10)	0.05 (1.3)	0.02 (0.6)	0.02 (0.6)
15	1.38 (35)	1.22 (31)	0.43 (11)	0.06 (1.4)	0.02 (0.6)	0.02 (0.6)
20	1.85 (47)	1.57 (40)	0.55 (14)	0.09 (2.4)	0.03 (0.8)	0.03 (0.8)
25	2.05 (52)	1.81 (45.9)	0.59 (15)	0.09 (2.4)	0.03 (0.8)	0.03 (0.8)
30	2.44 (62)	2.17 (55)	0.63 (16)	0.09 (2.4)	0.03 (0.8)	0.04 (1)
35	2.83 (72)	2.52 (64)	0.67 (17)	0.10 (2.5)	0.03 (0.8)	0.04 (1)
40	3.15 (80)	2.83 (72)	0.71 (18)	0.10 (2.5)	0.03 (0.8)	0.04 (1)
45	3.35 (85)	3.03 (77)	0.75 (19)	0.10 (2.5)	0.05 (1.2)	0.04 (1)
50	3.54 (90)	3.23 (82)	0.79 (20)	0.10 (2.5)	0.05 (1.2)	0.04 (1)
55	3.94 (100)	3.54 (90)	0.83 (21)	0.10 (2.5)	0.05 (1.2)	0.04 (1)
60	4.33 (110)	3.94 (100)	0.87 (22)	0.10 (2.5)	0.05 (1.2)	0.06 (1.5)
80	5.51 (140)	5.04 (128)	1.02 (26)	0.10 (2.5)	0.05 (1.2)	0.06 (1.5)

#### Notes:

Mounting dimensions are identical to ball bearings Series 62.

### Bore sizes and keyseats inches (mm)

Size	d <sup>H7</sup> Bore Size	Keyseat*
6	0.24 (6)	None
8	0.31 (8)	(2 X 1)
10	0.39 (10)	(3 X 1.4)
12	0.47 (12)	(4 X 1.8)
15	0.59 (15)	(5 X 1.2)
20	0.79 (20)	(6 X 1.6)
25	0.98 (25)	(8 X 2)
30	1.18 (30)	(8 X 2)
35	1.38 (35)	(10 X 2.4)
40	1.57 (40)	(12 X 2.2)
45	1.77 (45)	(14 X 2.1)
50	1.97 (50)	(14 X 2.1)
55	2.17 (55)	(16 X 2.4)
60	2.36 (60)	(18 X 2.3)
80	3.15 (80)	(22 X 3.1)

#### Notes:

\* AS6 without keyway. AS8-12 keyway to DIN 6885.1. Other sizes to DIN 6885.3 on page 129.

# General Purpose Clutches

## ASNU

Overrunning, Indexing, Backstopping External Bearing Support Required, Ramp & Roller Clutches



Model ASNU is a ramp & roller type clutch, non-bearing supported. Bearings are required to support axial and radial loads. Lubrication and sealing are required.

Nominal outer diameter is the same as a Series 63 ball bearing.

A typical arrangement is to install this type alongside a bearing within the same location tolerances, as shown.

The outer race has positive n6 tolerance, to give a press fit in a H7 housing. Additional side notches in the outer race provide positive torque transmission.

If the housing is to K6 tolerance, use of the notches is not necessary, but the housing must be strong enough not to expand after assembly.

This design can accept an axial misalignment of inner and outer race of  $\pm S/2$ .

These clutches are oil dipped at the factory but must be filled to the proper level before operation.

This clutch is designed for oil lubrication. For grease lubrication, reduce the maximum overrunning speed to 50% of listed value.

### Specifications

Size	Torque Capacity lb.ft. (Nm)	Overrunning Speed Max. RPM		Resistance after run-in lb.in. (Ncm)	Shipping Weight lb. (kg)
		Inner Race	Outer Race		
8	9 (12)	3,300	5,000	0.14 (1.6)	0.15 (0.07)
12	9 (12)	3,300	5000	0.14 (1.6)	0.13 (0.06)
15	22 (30)	2,400	3,600	0.17 (1.9)	0.24 (0.11)
17	36 (49)	2,300	3,400	0.17 (1.9)	0.33 (0.15)
20	58 (78)	2,100	3,100	0.17 (1.9)	0.42 (0.19)
25	92 (125)	1,700	2,600	0.50 (5.6)	0.84 (0.38)
30	188 (255)	1,400	2,200	1.20 (14)	1.19 (0.54)
35	283 (383)	1,200	1,900	1.40 (16)	1.63 (0.74)
40	397 (538)	1,100	1,700	3.30 (38)	2.03 (0.92)
45	576 (780)	1,000	1,600	3.80 (43)	2.89 (1.31)
50	748 (1013)	850	1,350	4.90 (55)	3.84 (1.74)
60	1,347 (1825)	750	1,050	9.70 (110)	6.11 (2.77)
70	1,697 (2300)	600	950	12.40 (140)	9.17 (4.16)
80	2,417 (3275)	550	850	15.90 (180)	13.43 (6.09)
90	3,930 (5325)	500	750	20.40 (230)	18.08 (8.2)
100	5,351 (7250)	450	680	33.60 (380)	27.78 (12.6)
120	9,963 (13500)	370	550	57.50 (650)	48.51 (22)
150	19,649 (26625)	300	460	88.50 (1000)	92.61 (42)
200	32,841 (44500)	230	350	177.10 (2000)	205.07 (93)

### Typical Mounting Arrangement

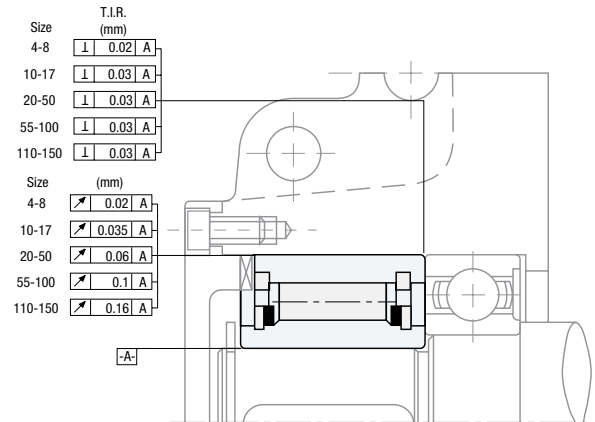

The ASNU clutch must be mounted adjacent to bearings to provide the concentricity and to support the axial and radial loads. Oil or grease lubrication must be provided along with seals to retain the lubricant.

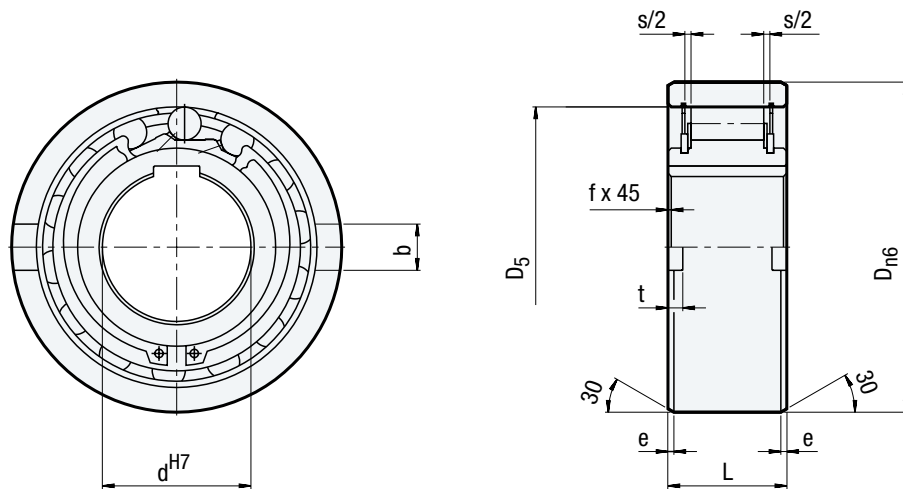

**Dimensions** inches (mm)

Size	D <sub>n6</sub>	L	D <sub>5</sub>	b	t	s	e	f
8	1.38 (35)	0.51 (13)	1.10 (28)	0.16 (4)	0.06 (1.4)	0.09 (2.4)	0.02 (0.6)	0.01 (0.3)
12	1.38 (35)	0.51 (13)	1.10 (28)	0.16 (4)	0.06 (1.4)	0.09 (2.4)	0.02 (0.6)	0.01 (0.3)
15	1.65 (42)	0.71 (18)	1.46 (37)	0.20 (5)	0.07 (1.8)	0.09 (2.4)	0.03 (0.8)	0.01 (0.3)
17	1.85 (47)	0.75 (19)	1.57 (40)	0.20 (5)	0.09 (2.3)	0.09 (2.4)	0.05 (1.2)	0.03 (0.8)
20	2.05 (52)	0.83 (21)	1.65 (42)	0.24 (6)	0.09 (2.3)	0.09 (2.4)	0.05 (1.2)	0.03 (0.8)
25	2.44 (62)	0.94 (24)	2.01 (51)	0.31 (8)	0.11 (2.8)	0.09 (2.4)	0.05 (1.2)	0.03 (0.8)
30	2.83 (72)	1.06 (27)	2.36 (60)	0.39 (10)	0.10 (2.5)	0.09 (2.4)	0.07 (1.8)	0.04 (1)
35	3.15 (80)	1.22 (31)	2.76 (70)	0.47 (12)	0.14 (3.5)	0.09 (2.4)	0.07 (1.8)	0.04 (1)
40	3.54 (90)	1.30 (33)	3.07 (78)	0.47 (12)	0.16 (4.1)	0.10 (2.5)	0.07 (1.8)	0.04 (1)
45	3.94 (100)	1.42 (36)	3.35 (85)	0.55 (14)	0.18 (4.6)	0.10 (2.5)	0.07 (1.8)	0.04 (1)
50	4.33 (110)	1.57 (40)	3.62 (92)	0.55 (14)	0.22 (5.6)	0.10 (2.5)	0.07 (1.8)	0.04 (1)
60	5.12 (130)	1.81 (46)	4.33 (110)	0.71 (18)	0.22 (5.5)	0.14 (3.6)	0.10 (2.6)	0.06 (1.5)
70	5.91 (150)	2.01 (51)	4.92 (125)	0.79 (20)	0.27 (6.9)	0.14 (3.6)	0.10 (2.6)	0.06 (1.5)
80	6.69 (170)	2.28 (58)	5.51 (140)	0.79 (20)	0.30 (7.5)	0.14 (3.6)	0.10 (2.6)	0.06 (1.5)
90	7.48 (190)	2.52 (64)	6.30 (160)	0.79 (20)	0.31 (8)	0.14 (3.6)	0.10 (2.6)	0.08 (2)
100	8.46 (215)	2.87 (73)	6.89 (175)	0.94 (24)	0.33 (8.5)	0.14 (3.6)	0.10 (2.6)	0.08 (2)
120	10.24 (260)	3.39 (86)	8.46 (215)	1.10 (28)	0.39 (10)	0.14 (3.6)	0.10 (2.6)	0.10 (2.5)
150	12.60 (320)	4.25 (108)	10.24 (260)	1.26 (32)	0.47 (12)	0.14 (3.6)	0.14 (3.6)	0.10 (2.5)
200	16.54 (420)	5.43 (138)	13.78 (350)	1.77 (45)	0.63 (16)	0.30 (7.6)	0.14 (3.6)	0.12 (3)

**Bore sizes and keyseats** inches (mm)

Size	d <sup>H7</sup> Bore Size	Keyseat*
8	0.31 (8)	(2 X 1)
12	0.47 (12)	(4 X 1.8)
15	0.59 (15)	(5 X 1.2)
17	0.67 (17)	(5 X 1.2)
20	0.79 (20)	(6 X 1.6)
25	0.98 (25)	(8 X 2)
30	1.18 (30)	(8 X 2)
35	1.38 (35)	(10 X 2.4)
40	1.57 (40)	(12 X 2.2)
45	1.77 (45)	(14 X 2.1)
50	1.97 (50)	(14 X 2.1)
60	2.36 (60)	(18 X 2.3)
70	2.76 (70)	(20 X 2.7)
80	3.15 (80)	(22 X 3.1)
90	3.54 (90)	(25 X 2.9)
100	3.94 (100)	(28 X 3.2)
120	4.72 (120)	(32 X 3.5)
150	5.91 (150)	(36 X 3.8)
200	7.87 (200)	—

\* For keyseat sizes see ASNU 8–12 and 200 use DIN 6885.1. All other sizes use DIN 6885.3 table on page 129.

# General Purpose Clutches

## FS20 and 50

Indexing, Backstopping External Bearing Support Required, Sprag Clutches



Series 20 and 50 clutches provide all the outstanding features of the Formsprag design for backstop applications with the exception that the customer supplies his own inner race, and provides the concentricity between the races.

This assembly is particularly advantageous on such applications as gear reducers where the backstop can be incorporated into a bearing bore and an extension of an existing shaft can be used for an inner race.

The outer surface of this clutch is basically the same as the outer surface of a standard bearing. The tolerance on the outer diameter is held to insure a proper fit (without pressing) into a continuation of the bore which accommodates the adjacent bearing. The tolerance on this bore should follow the bearing manufacturer's recommendation for the bearing used. Taper within this bore should not exceed .0002 inch per inch.

FS 20 and 50 clutches are oil dipped at the factory *but must be filled to the proper level before operation.*

The model FS 50 can not be used with lubricants that contain EP additives, see page 134. The model FS 20 has a special sprag design that will work with all types of lubricants including those with EP additives.

### Specifications

Size	Torque Capacity lb.in. (Nm)	Overrunning Speed (Inner Race only) Max. RPM		Shipping Weight lb. (kg)
		Grease* Oil-Mist or Spray	Pressure Lubrication or Oil Bath	
FS-20-3	468 (52.8)	2,500	2,500	0.5 (.22)
FS-20-4	600 (67.8)	2,500	2,500	0.75 (.34)
FS-20-5	960 (108.48)	2,500	2,500	0.75 (.34)
FS-20-6	2100 (237.3)	2,000	2,000	1.0 (.45)
FS-20-7	3300 (372.9)	2,000	2,000	1.25 (.56)
FS-20-8	4860 (549.18)	1,800	1,800	1.75 (.80)
FS-20-10	6900 (779.7)	1,800	1,800	2.0 (.91)
FS-50-9A	3,000 (339)	1,800	2,000	1.62 (.736)
FS-50-11A	6,300 (724)	1,800	2,000	2.60 (1.182)
FS-50-12A	8,000 (904)	1,800	2,000	3.03 (1.377)
FS-50-13	15,000 (1725)	1,200	1,750	6.20 (2.818)

\* Overrunning speeds are reduced 50% from listed values for grease lubrication.

### Typical Mounting Arrangements

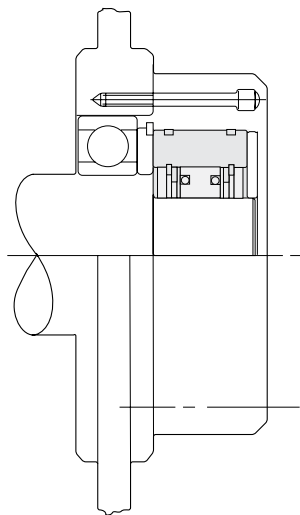

Series 20 and 50 clutch mounted inside the bearing retainer cap

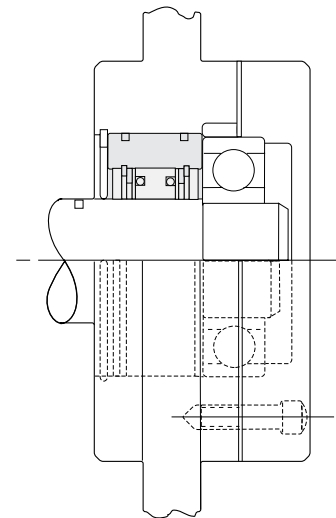

Series 20 and 50 clutch mounted directly in the housing bore



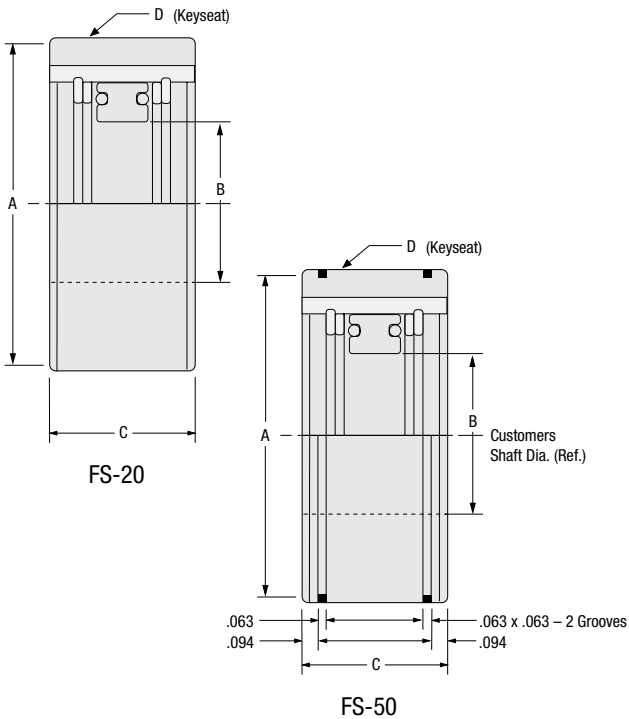

### Dimensions inches (mm)

Size	Standard Bearing Sizes O.D. Dia.	A	B	C	D
FS-20-3	203	1.5743/1.5728 (39.99/39.95)	0.650/0.649 (16.51/16.49)	1.0 (25.4)	1/8 x 1/16 (3.48 x 1.57)
FS-20-4	204	1.8498/1.8483 (46.98/46.95)	0.740/0.739 (18.80/18.77)	1.0 (25.4)	3/16 x 3/32 (4.75 x 2.36)
FS-20-5	205	2.0463/2.0448 (51.98/51.94)	0.930/0.929 (23.62/23.60)	1.0 (25.4)	3/16 x 3/32 (4.75 x 2.36)
FS-20-6	206	2.4403/2.4388 (61.98/61.95)	1.290/1.289 (32.77/32.74)	1.125 (28.58)	1/4 x 1/8 (6.35 x 3.18)
FS-20-7	207	2.8341/2.8326 (71.99/71.95)	1.657/1.656 (42.09/42.06)	1.125 (28.58)	1/4 x 1/8 (6.35 x 3.18)
FS-20-8	208	3.1491/3.1476 (79.99/79.95)	1.841/1.840 (46.76/46.74)	1.25 (31.75)	3/8 x 3/16 (9.52 x 4.75)
FS-20-10	210	3.5428/3.5413 (89.99/89.95)	2.209/2.208 (56.11/56.08)	1.25 (31.75)	3/8 x 3/16 (9.52 x 4.75)
FS-50-9A	207	2.8332/2.8322 (71.96/71.94)	1.1335/1.1325 (28.79/28.77)	1.25 (31.75)	.250 x .13 (6.35 x 3.30)
FS-50-11A	3L10	3.149/3.148 (79.98/79.96)	1.378/1.377 (35.00/34.98)	1.63 (41.40)	.375 x .19 (9.53 x 4.83)
FS-50-12A	3L11	3.542/3.541 (89.97/89.94)	1.541/1.540 (39.14/39.12)	1.63 (41.40)	.375 x .19 (9.53 x 4.83)
FS-50-13	XLS-3.25	4.750/4.749 (120.65/120.62)	2.0457/2.0447 (51.96/51.94)	1.75 (44.45)	.500 x .25 (12.7 x 6.35)

**Note:** Series 50 clutches are intended primarily for use as built-in backstops in reducers.

### Housing Tolerance

The recommended tolerance on the housing bore to assure proper clutch fit for the Model FS-20 clutches are listed in the following chart.

Sizes	Tolerance of housing bore
203 to 210	0 to +.001 (0 to +0.025 mm) TIR*

### Concentricity

The concentricity between the inner race (shaft) sprag diameter and backstop bore in the housing is critical. It can be measured as shown, with the base of the indicator mounted on the end of the shaft. The shaft end should be square with the sprag diameter.

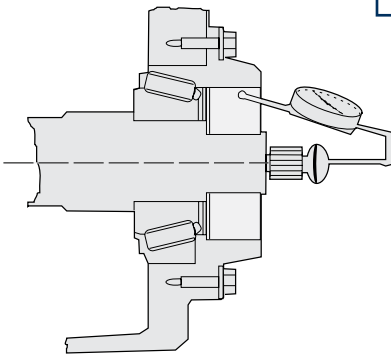

The concentricity requirements are listed below:

FS-50-9A, 11A, 12A	.003 TIR*
FS-50-13	.004 TIR*
FS-203-210	.002

\* Total Indicator Reading

**Note:** No snap ring grooves in sizes 203, 205, 206, 207, 208 or 210.

### WARNING

*Installation of a backstop into a system without the proper concentricity, shaft hardness requirements and lubrication can result in the unexpected back driving or slipping of the clutch. Carefully read and follow the instructions provided with the clutch assembly and the instructions provided by the original equipment manufacturer prior to installing the clutch. Failure to observe these precautions could result in bodily injury.*

### Shaft Requirements

The shaft extension which serves as the inner race should be carburized to a depth of .050 inches to .060 inches after grinding and hardened to Rockwell 58-62 "C". Taper on this shaft should also not exceed .0002 per inch. The core hardness should be 28-40 Rockwell "C". The microfinish should be 15-25 RMS.

### Lubrication

If possible, backstops should be mounted below the oil level.

The oil level should not be below the inner race (shaft).

**Note:** If backstop is mounted above the oil level, positive means such as spray or pressure lubrication should be provided to ensure adequate lubrication.

For grease lubrication the overrunning speeds are reduced 50% from listed values.

# General Purpose Clutches

## DC

Overrunning, Indexing, Backstopping External Bearing Support Required, Sprag Clutches



### Retainer Assemblies

Model DC is a sprag type dual cage retainer assembly without inner or outer races. It must be installed in a design providing races, bearing support for axial and radial loads, lubrication and sealing. The sprag annular space must be maintained. Inner and outer races must both have a minimum plain width "E", without any recess, to ensure the clutch functions correctly. The model DC part numbers that end in "-N" have a special Sprag design that will work with all types of lubricants including those with EP (Extreme Pressure) additives. Inner and outer races are also available, as shown

### Specifications

Size	Torque Capacity lb.ft. (Nm)	Overrunning Speed Max. RPM		Race		Annular Space in.* (mm)	Retainer Width			Shipping Weight lb. (kg)
		Inner Race "imax <sup>2</sup> (min. <sup>-1</sup> )	Outer Race "amax <sup>3</sup> (min. <sup>-1</sup> )	I.D. A +0.0003 -0.0002 in. (mm)	O.D. C ±0.0005 in. (mm)		E <sub>min.</sub> in. (mm)	D <sub>min.</sub> in. (mm)	B <sub>max.</sub> in. (mm)	
DC2222G-N	46 (63)	8,600	4,300	0.875 (22.225)	1.531 (38.885)	0.33 (8.33)	0.39 (10)	1.97 (50)	0.67 (17)	0.07 (0.03)
DC2776-N	88 (119)	6,900	3,400	1.093 (27.762)	1.749 (44.422)	0.33 (8.33)	0.53 (13.5)	2.28 (58)	0.83 (21)	0.12 (0.055)
DC3034-N	92 (124)	6,300	3,100	1.194 (30.34)	1.850 (47)	0.33 (8.33)	0.53 (13.5)	2.44 (62)	0.91 (23)	0.13 (0.06)
DC3175(3C)-N	117 (159)	6,000	3,000	1.250 (31.75)	1.906 (48.41)	0.33 (8.33)	0.53 (13.5)	2.48 (63)	0.94 (24)	0.13 (0.06)
DC3809A-N	203 (275)	5,000	2,500	1.499 (38.092)	2.156 (54.752)	0.33 (8.33)	0.63 (16)	2.80 (71)	1.14 (29)	0.19 (0.085)
DC4127(3C)-N	165 (224)	4,600	2,300	1.625 (41.275)	2.281 (57.935)	0.33 (8.33)	0.53 (13.5)	2.95 (75)	1.26 (32)	0.20 (0.09)
DC4445A-N	268 (363)	4,300	2,100	1.750 (44.45)	2.406 (61.11)	0.33 (8.33)	0.63 (16)	3.11 (79)	1.34 (34)	0.21 (0.095)
DC4972(4C)-N	226 (306)	3,800	1,900	1.958 (49.721)	2.613 (66.381)	0.33 (8.33)	0.53 (13.5)	3.39 (86)	1.50 (38)	0.22 (0.1)
DC5476A-N	387 (525)	3,500	1,700	2.156 (54.765)	2.812 (71.425)	0.33 (8.33)	0.63 (16)	3.62 (92)	1.65 (42)	0.24 (0.11)
DC5476A(4C)-N	387 (525)	3,500	1,700	2.156 (54.765)	2.812 (71.425)	0.33 (8.33)	0.63 (16)	3.62 (92)	1.65 (42)	0.29 (0.13)
DC5476B(4C)-N	568 (769)	3,500	1,700	2.156 (54.765)	2.812 (71.425)	0.33 (8.33)	0.83 (21)	3.62 (92)	1.65 (42)	0.40 (0.18)
DC5476C(4C)-N	731 (990)	3,500	1,700	2.156 (54.765)	2.812 (71.425)	0.33 (8.33)	1.0 (25.4)	3.62 (92)	1.65 (42)	0.44 (0.2)
DC5776A-N	446 (604)	3,300	1,600	2.274 (57.76)	2.930 (74.42)	0.33 (8.33)	0.63 (16)	3.86 (98)	1.73 (44)	0.24 (0.11)
DC6334B-N	595 (806)	3,000	1,500	2.494 (63.34)	3.150 (80)	0.33 (8.33)	0.83 (21)	4.09 (104)	1.97 (50)	0.39 (0.175)
DC7221(5C)-N	498 (675)	2,600	1,300	2.843 (72.217)	3.500 (88.877)	0.33 (8.33)	0.53 (13.5)	4.53 (115)	2.20 (56)	0.31 (0.14)
DC7221B-N	944 (1279)	2,600	1,300	2.843 (72.217)	3.500 (88.877)	0.33 (8.33)	0.83 (21)	4.53 (115)	2.20 (56)	0.41 (0.185)
DC7221B(5C)-N	944 (1279)	2,600	1,300	2.843 (72.217)	3.500 (88.877)	0.33 (8.33)	0.83 (21)	4.53 (115)	2.20 (56)	0.46 (0.21)
DC7969C(5C)-N	1504 (2038)	2,400	1,200	3.138 (79.698)	3.794 (96.358)	0.33 (8.33)	1.00 (25.4)	4.88 (124)	2.40 (61)	0.62 (0.28)
DC8334C-N	1517 (2055)	2,300	1,100	3.281 (83.34)	3.937 (100)	0.33 (8.33)	1.00 (25.4)	5.20 (132)	2.56 (65)	0.60 (0.27)
DC8729A-N	923 (1250)	2,200	1,100	3.437 (87.29)	4.093 (103.96)	0.33 (8.33)	0.63 (16)	5.28 (134)	2.64 (67)	0.36 (0.165)
DC10323A(5C)-N*	1190 (1612)	1,800	900	4.064 (103.231)	4.720 (119.891)	0.33 (8.33)	0.63 (16)	6.10 (155)	3.15 (80)	0.45 (0.205)
DC12334C-N*	3542 (4800)	1,500	750	4.856 (123.34)	5.512 (140)	0.33 (8.33)	1.00 (25.4)	7.24 (184)	3.78 (96)	0.88 (0.4)
DC12388C(11C)	3598 (4875)	1,500	750	4.878 (123.881)	5.625 (142.88)	0.37 (9.5)	1.00 (25.4)	7.32 (186)	3.78 (96)	0.88 (0.4)

\* ±0.075mm, except size DC12388C(11C) is ±0.10mm

on the following pages.

Alternatively, races can be made in case hardened steel shafts, or housings, to the specification below. Surface hardness of the finished part should be HRC 60 to 62, for a depth of .024" (.6mm) minimum.

Core hardness should be HRC35 to 45. Surface roughness should not exceed 22Ra. Maximum taper between races: .0003" (.007mm) for .984" (25mm) width.

### Races

DC races are offered for use with the DC retainer assemblies. The retainer assembly and races make a nonbearing supported clutch. Bearing support for axial and radial loads must be provided along with lubrication and sealing. The annular space tolerance must not be exceeded when all bearing clearances and mounting tolerances are considered. Taper between races should be below .0003" (.007mm) for .984" (25mm) width.

Outer races type A and B should be pressed into housings that will not deform after assembly.

Please contact our technical department if you need to transmit maximum clutch torque capacity with A and G type. Key stresses may have to be checked.

### Sprag Retainer Assemblies

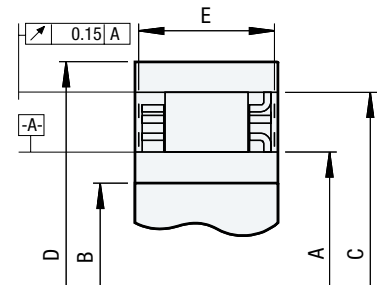
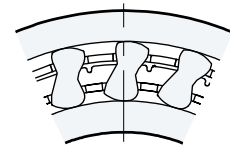

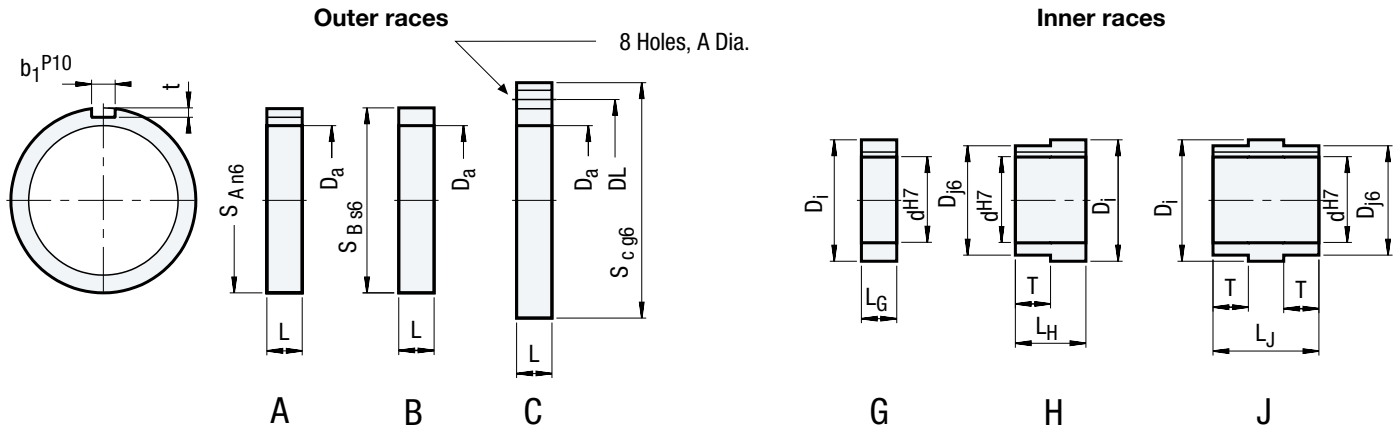

### Dimensions inches (mm)

Size	d <sup>H7*</sup>	L <sub>G</sub>	L <sub>H</sub>	L <sub>J</sub>	D <sub>j6</sub>	T	D <sub>i</sub> (+.008 / -.005)	L	S <sub>An6</sub>	b <sub>1</sub> P10	t	S <sub>Bs6</sub>	S <sub>Cg6</sub>	DL (±0.1)	A	D <sub>a</sub> (±0.013)
To be used with DC size 3809A:																
DC230A							1.5 (38.092)	0.6 (16)	2.8 (72)	0.2 (6)	0.1 (3.5)					2.2 (54.752)
DC230B							1.5 (38.092)	0.6 (16)				2.8 (72)				2.2 (54.752)
DC230C							1.5 (38.092)	0.6 (16)					3.7 (95)	3.1 (78)	0.28 (7)	2.2 (54.752)
DC230G10	0.39 (10)	0.6 (16)					1.5 (38.092)									
DC230G15	0.79 (15)	0.6 (16)					1.5 (38.092)									
DC230G20	0.79 (20)	0.6 (16)					1.5 (38.092)									
DC230H10	0.39 (10)		1.3 (33)		1.4 (35)	0.7 (17)	1.5 (38.092)									
DC230H15	0.59 (15)		1.3 (33)		1.4 (35)	0.7 (17)	1.5 (38.092)									
DC230H20	0.79 (20)		1.3 (33)		1.4 (35)	0.7 (17)	1.5 (38.092)									
DC230J10	0.39 (10)			2.0 (50)	1.4 (35)	0.7 (17)	1.5 (38.092)									
DC230J15	0.59 (15)			2.0 (50)	1.4 (35)	0.7 (17)	1.5 (38.092)									
DC230J20	0.79 (20)			2.0 (50)	1.4 (35)	0.7 (17)	1.5 (38.092)									
To be used with DC sizes 5476A, 5476A(4C):																
DC167A							2.2 (54.765)	0.6 (16)	3.5 (90)	0.4 (10)	0.2 (5)					2.8 (71.425)
DC167B							2.2 (54.765)	0.6 (16)				3.5 (90)				2.8 (71.425)
DC167C							2.2 (54.765)	0.6 (16)					4.3 (110)	3.7 (95)	0.35 (9)	2.8 (71.425)
DC167G25	0.98 (25)	0.6 (16)					2.2 (54.765)									
DC167G30	1.18 (30)	0.6 (16)					2.2 (54.765)									
DC167G35	1.38 (35)	0.6 (16)					2.2 (54.765)									
DC167H25	0.98 (25)		1.4 (35)		2.0 (50)	0.7 (19)	2.2 (54.765)									
DC167H30	1.18 (30)		1.4 (35)		2.0 (50)	0.7 (19)	2.2 (54.765)									
DC167H35	1.38 (35)		1.4 (35)		2.0 (50)	0.7 (19)	2.2 (54.765)									
DC167J25	0.98 (25)			2.1 (54)	2.0 (50)	0.7 (19)	2.2 (54.765)									
DC167J30	1.18 (30)			2.1 (54)	2.0 (50)	0.7 (19)	2.2 (54.765)									
DC167J35	1.38 (35)			2.1 (54)	2.0 (50)	0.7 (19)	2.2 (54.765)									
To be used with DC sizes 7221 (5C), 7221B, 7221B (5C):																
DC168A							2.8 (72.217)	0.8 (21)	4.3 (110)	0.6 (14)	0.2 (5.5)					3.5 (88.877)
DC168B							2.8 (72.217)	0.8 (21)				4.3 (110)				3.5 (88.877)
DC168C							2.8 (72.217)	0.8 (21)					5.5 (140)	4.7 (120)	0.43 (11)	3.5 (88.877)
DC168G40	1.57 (40)	0.8 (21)					2.8 (72.217)									
DC168G45	1.77 (45)	0.8 (21)					2.8 (72.217)									
DC168G50	1.97 (50)	0.8 (21)					2.8 (72.217)									
DC168H40	1.57 (40)		1.7 (42)		2.6 (65)	0.8 (21)	2.8 (72.217)									
DC168H45	1.77 (45)		1.7 (42)		2.6 (65)	0.8 (21)	2.8 (72.217)									
DC168H50	1.97 (50)		1.7 (42)		2.6 (65)	0.8 (21)	2.8 (72.217)									
DC168J40	1.57 (40)			2.5 (63)	2.6 (65)	0.8 (21)	2.8 (72.217)									
DC168J45	1.77 (45)			2.5 (63)	2.6 (65)	0.8 (21)	2.8 (72.217)									
DC168J50	1.97 (50)			2.5 (63)	2.6 (65)	0.8 (21)	2.8 (72.217)									
To be used with DC size 10323A (3C):																
DC235A							4.1 (103.231)	0.6 (16)	5.9 (150)	0.8 (20)	0.3 (7.5)					4.7 (119.891)
DC235B							4.1 (103.231)	0.6 (16)				5.9 (150)				4.7 (119.891)
DC235C							4.1 (103.231)	0.6 (16)					7.5 (190)	6.7 (170)	0.43 (11)	4.7 (119.891)
DC235G55	2.17 (55)	0.6 (16)					4.1 (103.231)									
DC235G60	2.36 (60)	0.6 (16)					4.1 (103.231)									
DC235G75	2.95 (75)	0.6 (16)					4.1 (103.231)									
DC235H55	2.17 (55)		1.7 (43)		3.9 (100)	1.1 (27)	4.1 (103.231)									
DC235H60	2.36 (60)		1.7 (43)		3.9 (100)	1.1 (27)	4.1 (103.231)									
DC235H75	2.95 (75)		1.7 (43)		3.9 (100)	1.1 (27)	4.1 (103.231)									
DC235J55	2.17 (55)			2.8 (70)	3.9 (100)	1.1 (27)	4.1 (103.231)									
DC235J60	2.36 (60)			2.8 (70)	3.9 (100)	1.1 (27)	4.1 (103.231)									

\* For keyseat sizes, see DIN 6885.1 on page 129

# General Purpose Clutches

## RSCI

Overrunning, Backstopping External Bearing Support Required, Centrifugal Throw-out (C/T) Sprag Clutches



Model RSCI is a centrifugal throwout sprag type overrunning clutch with the inner race rotating. Only the inner race is designed for overrunning.

The RSCI is not a self-supported design. Bearings must be provided to ensure concentricity of the inner and outer races and to support axial and radial loads. Concentricity and run-out limits must be observed.

Primarily designed as a backstop, this model can also be used as an overrunning clutch in creep drives, where the overrunning speed is high, but the driving speed is low, and does not exceed the maximum driving speed shown in the table.

When used as a backstop, it must be checked that the overrunning speed will not go below the sprag lift-off speed given in the specifications table.

The model RSCI has a special sprag design that will work with all types of lubricants including those with EP additives. This sprag design feature allows for clutch usage inside gearboxes without separate lubrication.

If lubricants with EP additives are used, the concentricity tolerance should be reduced by one half.

An oil mist is generally sufficient. Grease lubrication may be acceptable if the unit operates mostly in the overrunning condition, as in electric motors.

Centering of the outer race must be based on the inner race bore, not the sprag cage.

Optional F8 cover must be ordered separately.

For bolt tightening torque values, see page 134.

### Specifications

Size	Torque Capacity lb.ft. (Nm)	Speeds			Shipping Weight lb. (kg)
		$n_{max}^{2)}$ ( $min^{-1}$ )	$n_{min}^{3)}$ ( $min^{-1}$ )	$n_{max}^{4)}$ ( $min^{-1}$ )	
20	156 (212)	315	750	15,000	3.31 (1.5)
25	235 (319)	300	725	14,000	3.53 (1.6)
30	277 (375)	290	700	11,000	3.97 (1.8)
35	406 (550)	280	670	11,000	4.63 (2.1)
40	590 (800)	260	630	8,000	5.95 (2.7)
45	673 (912)	255	610	7,000	6.39 (2.9)
50	1,033 (1400)	235	560	6,000	9.48 (4.3)
60	1734 (2350)	210	510	6,000	14.33 (6.5)
70	2,250 (3050)	195	470	4,000	18.96 (8.6)
80	3,321 (4500)	180	440	4,000	27.56 (12.5)
80M	4,264 (5800)	155	375	4,000	29 (13.1)
90	3,595 (5600)	170	410	3,000	38.37 (17.4)
90M	6,420 (8700)	145	350	3,000	40.3 (18.3)
100	7,749 (10500)	145	355	3,000	62.0 (28)
100M	11,808 (16000)	140	340	2,400	66 (30)
130	11,623 (15750)	135	330	2,400	77.18 (35)
180	23,247 (31500)	115	285	1,300	134 (61)
180M	36,900 (50000)	90	220	1,300	202 (92)
180-II	46,494 (63000)	115	285	1,300	260 (118)

#### Notes:

Keyway to DIN 6885.1

### Typical Mounting Arrangement

The Model RSCI must be mounted next to a bearing to provide the inner race to outer race concentricity and support any radial or axial loads. This clutch must be enclosed and coated with a film of grease or oil mist.

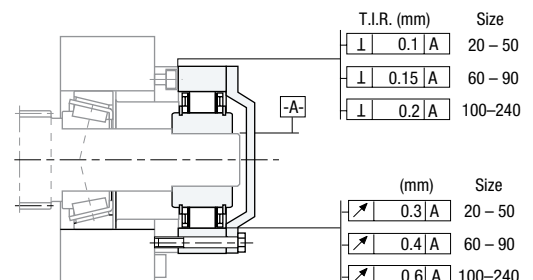

### RSCI 20-220

### F8

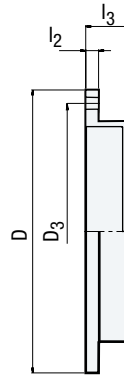
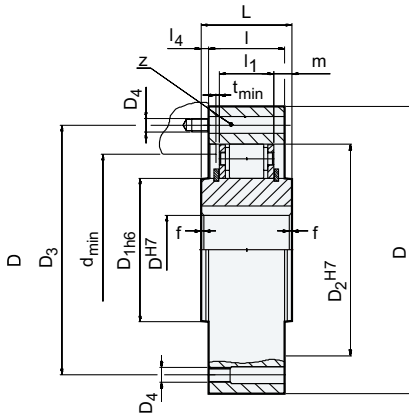

Dimensions inches (mm)

Size	D	D <sub>1h6</sub>	D <sub>2H7</sub>	D <sub>3</sub>	D <sub>4</sub>	Z # of holes	L	l	l <sub>1</sub>	l <sub>4</sub>	f x 45°	d <sub>min.</sub>	m	t <sub>min.</sub>	l <sub>2</sub>	l <sub>3</sub>
20	3.54 (90)	1.42 (36)	2.60 (66)	3.07 (78)	M6	6	1.38 (35)	1.38 (35)	0.98 (25)	0	0.03 (0.8)	2.05 (52)	0.20 (5)	0.04 (1)	0.31 (8)	0.63 (16)
25	3.74 (95)	1.57 (40)	2.76 (70)	3.23 (82)	M6	6	1.38 (35)	1.38 (35)	0.98 (25)	0	0.04 (1)	2.20 (56)	0.20 (5)	0.04 (1)	0.31 (8)	0.63 (16)
30	3.94 (100)	1.77 (45)	2.95 (75)	3.43 (87)	M6	6	1.38 (35)	1.38 (35)	0.98 (25)	0	0.06 (1.5)	2.44 (62)	0.20 (5)	0.04 (1)	0.31 (8)	0.63 (16)
35	4.33 (110)	1.97 (50)	3.15 (80)	3.78 (96)	M6	8	1.38 (35)	1.38 (35)	0.98 (25)	0	0.06 (1.5)	2.60 (66)	0.20 (5)	0.04 (1)	0.31 (8)	0.63 (16)
40	4.92 (125)	2.36 (60)	3.54 (90)	4.25 (108)	M8	8	1.38 (35)	1.38 (35)	0.98 (25)	0	0.06 (1.5)	2.99 (76)	0.20 (5)	0.04 (1)	0.39 (10)	0.83 (21)
45	5.12 (130)	2.56 (65)	3.74 (95)	4.41 (112)	M8	8	1.38 (35)	1.38 (35)	0.98 (25)	0	0.06 (1.5)	3.23 (82)	0.20 (5)	0.04 (1)	0.39 (10)	0.83 (21)
50	5.91 (150)	3.15 (80)	4.33 (110)	5.20 (132)	M8	8	1.57 (40)	1.57 (40)	0.98 (25)	0	0.06 (1.5)	3.94 (100)	0.30 (7.5)	0.04 (1)	0.39 (10)	0.83 (21)
60	6.89 (175)	3.35 (85)	4.92 (125)	6.10 (155)	M10	8	2.36 (60)	1.97 (50)	1.42 (36)	0.20 (5)	0.08 (2)	4.33 (110)	0.47 (12)	0.08 (2)	0.47 (12)	1.38 (35)
70	7.48 (190)	3.74 (100)	5.51 (140)	6.50 (165)	M10	12	2.36 (60)	1.97 (50)	1.42 (36)	0.20 (5)	0.08 (2)	4.72 (120)	0.47 (12)	0.08 (2)	0.47 (12)	1.38 (35)
80	8.27 (210)	4.53 (120)	6.30 (160)	7.28 (185)	M10	12	2.76 (70)	2.36 (60)	1.42 (36)	0.20 (5)	0.08 (2)	5.51 (140)	0.67 (17)	0.12 (3)	0.47 (12)	1.38 (35)
80M	8.27 (210)	4.72 (120)	6.30 (160)	7.28 (185)	M10	12	2.76 (70)	2.36 (60)	1.81 (46)	0.20 (5)	0.08 (2)	5.51 (140)	0.47 (12)	0.08 (2)	0.47 (12)	1.38 (35)
90	9.06 (230)	5.51 (140)	7.09 (180)	8.11 (206)	M12	12	3.15 (80)	2.76 (70)	1.42 (36)	0.20 (5)	0.10 (2.5)	6.30 (160)	0.87 (22)	0.12 (3)	0.47 (12)	1.38 (35)
90M	9.65 (245)	5.51 (140)	7.09 (180)	8.11 (206)	M12	12	3.15 (80)	2.76 (70)	1.81 (46)	0.20 (5)	0.10 (3)	6.30 (160)	0.67 (17)	0.08 (2)	0.47 (12)	1.38 (35)
100	11.42 (290)	5.51 (140)	8.27 (210)	10.15 (258)	M16	12	3.54 (90)	3.15 (80)	2.07 (52.6)	0.20 (5)	0.10 (2.5)	7.09 (180)	0.73 (18.6)	0.12 (3)	0.59 (15)	1.46 (37)
100M	11.42 (290)	6.69 (170)	8.27 (210)	10.16 (258)	M16	12	3.54 (90)	3.15 (80)	2.48 (63)	0.20 (5)	0.10 (3)	7.87 (200)	0.53 (14)	0.08 (2)	0.47 (12)	1.38 (35)
130	12.68 (322)	6.69 (170)	9.45 (240)	10.94 (278)	M16	12	3.54 (90)	3.15 (80)	2.07 (52.6)	0.20 (5)	0.12 (3)	8.27 (210)	0.73 (18.6)	0.12 (3)	0.59 (15)	1.46 (37)
180	16.22 (412)	— (240)	12.20 (310)	14.17 (360)	M20	12	3.54 (90)	3.15 (80)	2.07 (52.6)	0.20 (5)	0.14 (3.5)	11.02 (280)	0.73 (18.6)	0.12 (3)	0.71 (18)	1.73 (44)
180M	16.61 (422)	9.45 (240)	12.20 (310)	14.57 (370)	M20	18	4.72 (120)	4.72 (120)	3.27 (83)	0 (0)	0.16 (4)	11.02 (280)	0.73 (19)	0.08 (2)		
180-II	16.22 (412)	— (240)	12.20 (310)	14.17 (360)	M20	24	6.30 (160)	3.15 (80)	4.64 (118)	0 (0)	0.14 (3.5)	11.81 (280)	0.83 (21)	0.12 (3)	0.71 (18)	1.73 (44)

**Note:**

F8 cover must be ordered separately.

\* Clearance mounting holes for listed bolt sizes.

\*\* Two extra tapped removal holes @ 180°.

### Bore sizes and keyseats

inches (mm)

Size	d <sup>H7</sup> Bore Size	Keyseat*
20	0.79 (20)	(6 X 2.8)
25	0.98 (25)	(8 X 3.3)
30	1.18 (30)	(8 X 3.3)
35	1.38 (35)	(10 X 3.3)
40	1.57 (40)	(12 X 3.3)
45	1.77 (45)	(14X 3.8)
50	1.97 (50)	(14X 3.8)
60	2.36 (60)	(18 X 4.4)
70	2.76 (70)	(20 X 4.9)
80	3.15 (80)	(22 X 5.4)
80M	3.15 (80)	(22 x 5.4)
90	3.54 (90)	(25 X 5.4)
90M	3.54 (90)	(25 X 5.4)
100	3.94 (100)	(28 X 6.4)
100M	3.94 (100)	(28 X 6.4)
130	5.12 (130)	(32 X 7.4)
180	7.08 (180)	(1)
180M	7.08 (180)	(1)
180-II	7.08 (180)	(1)

\* For keyseat sizes see DIN 6885.1 table on page 129.

# General Purpose Clutches

## RSCI

**Overrunning, Backstopping** External Bearing Support Required, Centrifugal Throw-out (C/T) Sprag Clutches



Model RSCI is a centrifugal throwout sprag type overrunning clutch with the inner race rotating. Only the inner race is designed for overrunning.

The RSCI is not a self-supported design. Bearings must be provided to ensure concentricity of the inner and outer races and to support axial and radial loads. Concentricity and run-out limits must be observed.

Primarily designed as a backstop, this model can also be used as an overrunning clutch in creep drives, where the overrunning speed is high, but the driving speed is low, and does not exceed the maximum driving speed shown in the table.

When used as a backstop, it must be checked that the overrunning speed will not go below the sprag lift-off speed given in the specifications table.

The model RSCI has a special sprag design that will work with all types of lubricants including those with EP additives. This sprag design feature allows for clutch usage inside gearboxes without separate lubrication.

If lubricants with EP additives are used, the concentricity tolerance should be reduced by one half.

An oil mist is generally sufficient. Grease lubrication may be acceptable if the unit operates mostly in the overrunning condition, as in electric motors.

Centering of the outer race must be based on the inner race bore, not the sprag cage.

Optional F8 cover must be ordered separately.

For bolt tightening torque values, see page 134.

### Specifications

Size	Torque Capacity lb.ft. (Nm)	Speeds			Shipping Weight lb. (kg)
		Max. Drive	Sprag Lift-off	Max. RPM Inner Race Overrunning	
180 II-M	73,800 (100000)	90	220	1,300	418 (190)
220	34,133 (42500)	110	265	1,100	194.04 (88)
220M	50,184 (68000)	85	205	1,100	240 (109)
220-II	70,849 (85000)	110	265	1,100	350 (159)
220 II-M	100,368 (136000)	85	205	1,100	548 (249)
240	38,376 (52000)	105	250	1,100	209 (95)
240M	61,254 (83000)	80	195	1,100	301 (137)
240 II	76,752 (104000)	105	250	1,100	420 (191)
240 II-M	122,508 (166000)	80	195	1,100	551 (250)
260	47,970 (65000)	100	240	1,000	286 (130)
260M	73,800 (100000)	75	185	1,000	403 (183)
260 II	95,940 (130000)	100	240	1,000	576 (262)
260 II-M	147,600 (200000)	75	185	1,000	812 (369)
300	57,564 (78000)	90	225	1,000	383 (174)
300M	92,250 (125000)	70	175	1,000	462 (210)
300 II	115,128 (156000)	90	225	1,000	772 (351)
300 II-M	184,500 (250000)	70	175	1,000	1007 (457)

#### Notes:

Keyway to DIN 6885.1

### RSCI 20-220

### F8

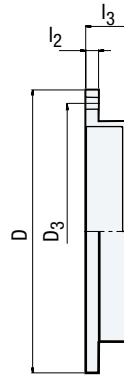
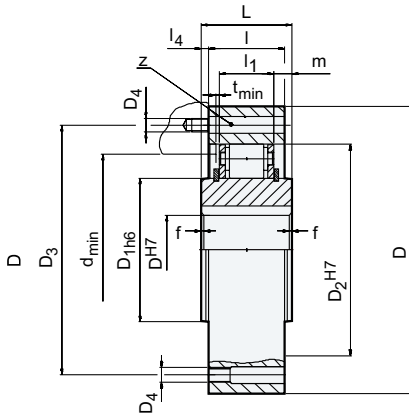

Dimensions inches (mm)

Size	D	D <sub>1H6</sub>	D <sub>2H7</sub>	D <sub>3</sub>	D <sub>4</sub>	Z # of holes	L	I	I <sub>1</sub>	I <sub>4</sub>	f x 45°	d <sub>min.</sub>	m	t <sub>min.</sub>	l <sub>2</sub>	l <sub>3</sub>
180 II-M	16.73 (425)	9.45 (240)	12.20 (310)	14.57 (370)	M24	24	9.45 (240)	9.45 (240)	6.93 (176)	0 (0)	0.16 (4)	11.02 (280)	1.26 (32)	0.12 (3)		
220	18.50 (470)	— (290)	14.17 (360)	16.14 (410)	M20	16	4.13 (105)	3.15 (80)	2.31 (58.6)	0.20 (5)	0.16 (4)	12.99 (330)	0.77 (19.5)	0.12 (3)	0.71 (18)	2.64 (67)
220M	18.90 (480)	11.42 (290)	14.17 (360)	16.14 (410)	M24	16	4.72 (120)	4.72 (120)	3.27 (83)	0 (0)	0.16 (4)	12.99 (330)	0.73 (19)	0.08 (2)		
220-II	18.89 (480)	— (290)	14.17 (360)	16.14 (410)	M24	18	6.30 (160)	6.30 (160)	5.12 (130)	0 (0)	0.16 (4)	14.17 (330)	0.59 (15)	0.12 (3)	0.71 (18)	2.64 (67)
220 II-M	19.29 (490)	11.42 (290)	14.17 (360)	16.73 (425)	M30	20	9.45 (240)	9.45 (240)	6.93 (176)	0 (0)	0.16 (4)	12.99 (330)	1.26 (32)	0.08 (2)		
240	19.69 (500)	12.60 (320)	15.35 (390)	17.32 (440)	M20	16	4.13 (105)	3.54 (90)	2.36 (60)	0.30 (8)	0.16 (4)	14.17 (360)	0.59 (15)	0.08 (2)		
240M	20.47 (520)	12.60 (320)	15.35 (390)	17.32 (440)	M24	16	4.72 (120)	4.72 (120)	3.27 (83)	0 (0)	0.16 (4)	14.17 (360)	0.73 (19)	0.08 (2)		
240 II	19.88 (505)	12.60 (320)	15.35 (390)	17.32 (440)	M24	24	7.09 (180)	7.09 (180)	5.20 (132)	0 (0)	0.16 (4)	14.17 (360)	0.94 (24)	0.08 (2)		
240 II-M	20.87 (530)	12.60 (320)	15.35 (390)	17.32 (440)	M30	24	9.45 (240)	9.45 (240)	6.93 (176)	0 (0)	0.16 (4)	14.17 (360)	1.26 (32)	0.08 (2)		
260	21.65 (550)	14.17 (360)	16.93 (430)	19.69 (500)	M24	16	4.13 (105)	4.13 (105)	2.36 (60)	0 (0)	0.16 (4)	15.75 (400)	0.89 (23)	0.08 (2)		
260M	22.83 (580)	14.17 (360)	16.93 (430)	19.69 (500)	M24	24	4.92 (125)	4.92 (125)	3.27 (83)	0 (0)	0.16 (4)	15.75 (400)	0.83 (21)	0.08 (2)		
260 II	21.65 (550)	14.17 (360)	16.93 (430)	19.69 (500)	M24	24	8.27 (210)	8.27 (210)	5.20 (132)	0 (0)	0.16 (4)	15.75 (400)	1.54 (39)	0.08 (2)		
260 II-M	22.83 (580)	14.17 (360)	16.93 (430)	19.69 (500)	M30	24	9.84 (250)	9.84 (250)	6.93 (176)	0 (0)	0.16 (4)	15.75 (400)	1.46 (37)	0.08 (2)		
300	24.80 (630)	16.14 (410)	18.90 (480)	22.05 (560)	M24	24	4.13 (105)	4.13 (105)	2.36 (60)	0 (0)	0.16 (4)	18.11 (460)	0.89 (23)	0.12 (3)		
300M	24.80 (630)	16.14 (410)	18.90 (480)	22.05 (560)	M24	24	4.92 (125)	4.92 (125)	3.27 (83)	0 (0)	0.16 (4)	18.11 (460)	0.83 (21)	0.12 (3)		
300 II	24.80 (630)	16.14 (410)	18.90 (480)	22.05 (560)	M24	24	8.27 (210)	8.27 (210)	5.28 (134)	0 (0)	0.16 (4)	18.11 (460)	1.50 (38)	0.12 (3)		
300 II-M	24.80 (630)	16.14 (410)	18.90 (480)	22.05 (560)	M30	24	9.84 (250)	9.84 (250)	7.19 (182.6)	0 (0)	0.16 (4)	18.11 (460)	1.32 (33.7)	0.12 (3)		

**Note:**

F8 cover must be ordered separately.

\* Clearance mounting holes for listed bolt sizes.

\*\* Two extra tapped removal holes @ 180°.

**Bore sizes  
and keyseats**

inches (mm)

Size	d <sup>H7</sup> Bore Size	Keyseat*
180 II-M	7.08 (180)	(1)
220	8.66 (220)	(1)
220M	8.66 (220)	(1)
220 II	8.66 (220)	(1)
220 II-M	8.66 (220)	(1)
240	9.45 (240)	(1)
240M	9.45 (240)	(1)
240 II	9.45 (240)	(1)
240 II-M	9.45 (240)	(1)
260	10.23 (260)	(1)
260M	10.23 (260)	(1)
260 II	10.23 (260)	(1)
260 II-M	10.23 (260)	(1)
300	11.81 (300)	(1)
300M	11.81 (300)	(1)
300 II	11.81 (300)	(1)
300 II-M	11.81 (300)	(1)

\* Keyseat information available on request.

# Special Purpose Clutches

## FS 100, 200 and 300

Overrunning, Indexing, Backstopping External Bearing Support Required, Sprag Clutches

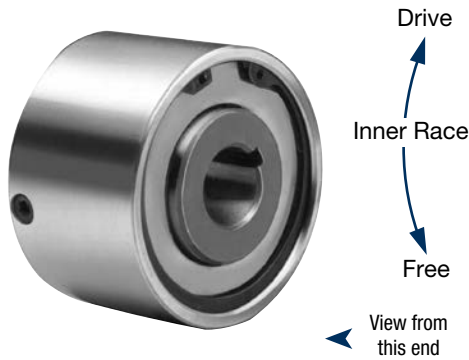

Right Hand rotation shown.  
(Left Hand opposite.)

Specify direction of rotation when ordering.

This clutch is intended for application at the end of a shaft. A snap-ring bearing must be inserted before installing. Basically an indexing clutch, it can however be used as an overrunning or backstop clutch. An adequate seal or cover must be provided at the open end to retain lubricant. Shaft end must be turned down and threaded to accommodate bearing and lock nut.

FS 100 through 300 clutches are oil dipped at the factory but *must be filled to the proper level before operation.*

For further information, see *Installation and Maintenance Bulletin No. 2218, P-222-9.*

### Specifications

Size	Torque Capacity lb.ft. (Nm)	Overrunning Speed Max. RPM		Power Rating per 100 RPM HP (kw)	Resistance after run-in lb.ft. (Nm)	Shipping Weight lb. (kg)
		Inner Race	Outer Race			
100	70 (95)	1,800	450	1.1 (0.8)	3 (4.0)	1.75 (.79)
200	230 (312)	1,800	450	2.8 (2.1)	7.5 (10.0)	4.5 (2.04)
300	440 (607)	1,200	300	5.5 (4.1)	10 (13.56)	7.75 (3.52)

### Typical Mounting Arrangements

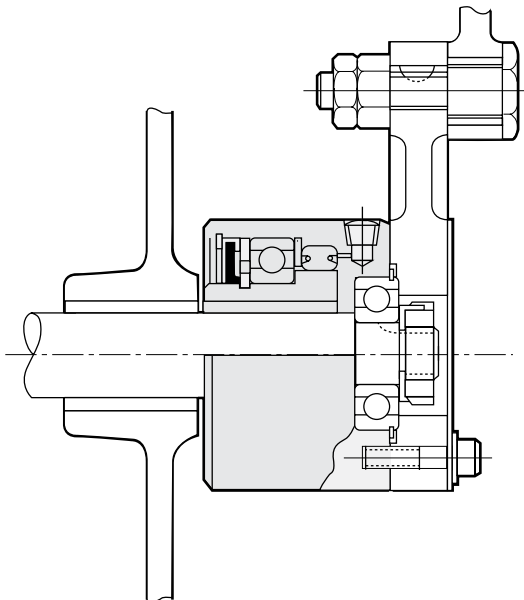

**Indexing Clutch**

The Model FS clutches require a snap-ring bearing (furnished by customer) mounted in the open end of the clutch as shown. An adequate seal or cover must be provided at the open end to retain lubricant. The shaft end must be turned down or threaded to accommodate the bearing or lock nut. All fasteners are recommended to be grade 8 bolts.

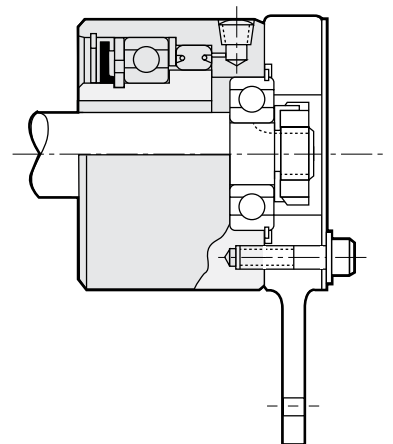

**Backstop Clutch**



# Special Purpose Clutches

## FS 100, 200 and 300

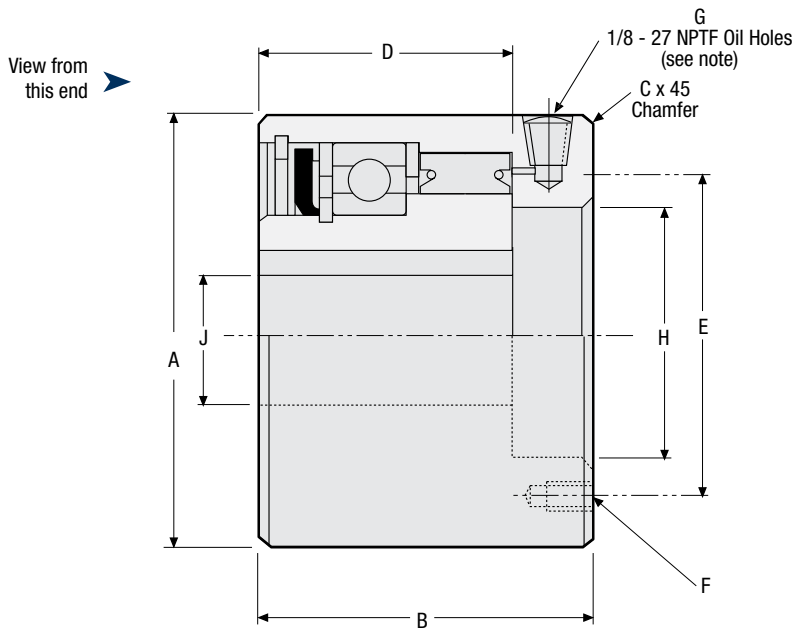

### Notes:

Angle — oil hole to mounting bolt hole

Model 100 = 45°

200 = 45°

300 = 30°

### Bore sizes and keyseats\* inches (mm)

Size	J Bore Size	Keyseat	Bore Range	
			Min.	Max.
100	.500 (12.70)	1/8 x 1/16 (3.18 x 1.59)	.500 (12.70)	.625 (15.88)
	.625 (15.88)	3/16 x 3/32 (4.75 x 2.38)		
	1.00 (25.40)	1/4 x 1/8 (6.35 x 3.18)		
200	1.125 (28.57)	3/8 x 3/16 (9.52 x .475)	1.00 (25.40)	1.313 (33.35)
	1.250 (31.75)			
	1.313 (33.35)			
	1.00 (25.40)			
300	1.750 (44.45)	3/8 x 3/16 (9.52 x .475)	1.00 (25.40)	2.00 (50.80)
	2.00 (50.80)	1/2 x 1/4 (12.70 x 6.3)		
	1.00 (25.40)	1/4 x 1/8 (6.35 x 3.18)		

\* For Bore Sizes/Shaft Tolerances, see page 128.

### Dimensions inches (mm)

Size	A	B	C	D	E	F			G	Snap Ring Ball Bearing		
						Number	Thread	Depth		Bore H	Bearing No.	Bearing I.D.
100	2.375 (60.3)	2.125 (53.9)	.031 (.79)	1.500 (38.1)	1.875 (47.6)	4	1/4 - 28 NF	.375 (9.52)	2 @ 180°	1.1811/1.1816 (29.9/30.0)	200	.3937 (9.9)
200	3.562 (142.8)	2.281 (57.9)	.031 (.79)	1.687 (42.8)	2.750 (69.8)	4	5/16 - 24 NF	.375 (9.52)	2 @ 180°	2.0470/2.0475 (51.9/52.0)	304	.7874 (19.9)
											205	.9843 (25.0)
300	4.500 (114.3)	2.750 (69.8)	.062 (1.57)	1.937 (49.2)	3.750 (95.2)	6	3/8 - 24 NF	.500 (12.7)	3 @ 120°	2.8345/2.8349 (71.9/72.0)	306	1.1811 (29.9)
											207	1.3780 (35.0)

# Special Purpose Ball Bearing Clutches

## HPO

### Overrunning, Backstopping Ball Bearing Supported, Sprag Clutch



The HPO series is especially designed for high speed outer race overrunning applications, such as high speed dual drives or standby drives.

HPO clutches are grease lubricated and equipped with labyrinth seals. Formchrome® sprags and special retainers are incorporated for maximum service life and speed capability. These clutches mount on a through shaft, with the inner race driven by a key. The ground O.D. of the outer race is designed as the mounting surface for attaching parts and is concentric with the bore. Tapped holes are provided in each end of the outer race for securing parts to the clutch.

Refer to Bore Sizes/Shaft Tolerance chart for mounting data, page 128.

Standard keys are supplied by Formsprag at no additional charge on models 750, 800, 900 and 1027.

HPO-720 through 1027 clutches are shipped from the factory packed with Fiske Brothers Aero-Lubriplate grease.

For further information see Installation & Maintenance Bulletin No. 2212, P-222-5.

### Typical Mounting Arrangement

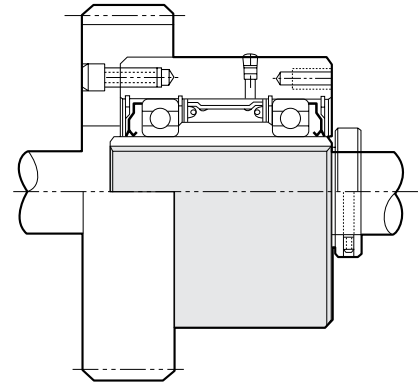

The Model HPO clutches must be axially restrained, see accessories page 122 for set collars, restraint keys and OSHA covers, etc. All fasteners are recommended to be grade 8 bolts.

## Specifications

Size	Torque Capacity lb.ft. (Nm)	Overrunning Speed Max. RPM		Resistance after run-in lb.ft. (Nm)	Lubrication (Grease) Required oz. (ml)	Shipping Weight lb. (kg)
		Inner Race	Outer Race			
720	3,200 (4339)	600	3,000	2.75 (3.373)	6.5 (192)	42 (19)
750	4,800 (6508)	525	2,600	3.75 (5.08)	7 (207)	83 (38)
800	8,000 (10848)	475	2,100	5.25 (7.12)	8 (236.5)	102 (46)
900	12,000 (16272)	400	1,850	6.25 (8.47)	18 (532)	156 (71)
1027	18,000 (24408)	300	1,500	10 (13.56)	28 (828)	250 (113)

#### Notes:

Check key and shaft stress before making final clutch selection since this may determine the maximum allowable drive torque capacity.

# Special Purpose Ball Bearing Clutches

HPO

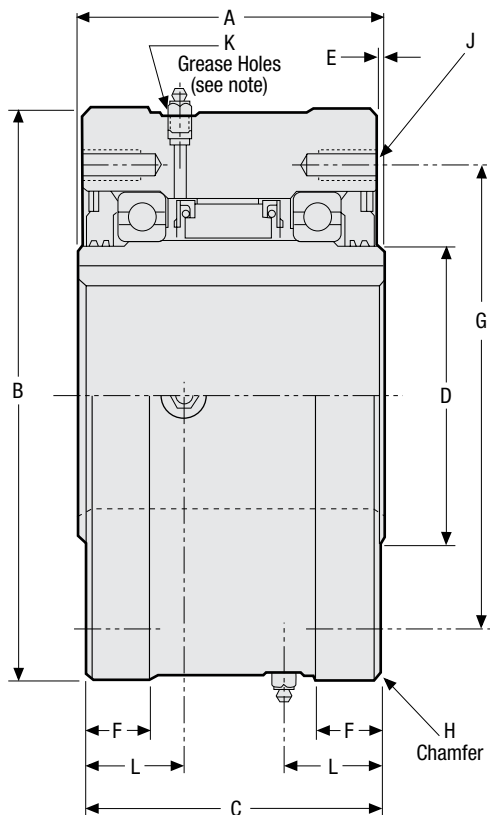

**Notes:**

Angle — oil hole to mounting bolt hole

- Model 750 = 0° to 30°
- 800 = 0° to 45°
- 900 = 0° to 18°
- 1027 = 15°

**Bore sizes and keyseats\* inches (mm)**

(Metric bore also available)

Size	Bore Size	Keyseat	Bore Range	
			Min.	Max.
720	2.00 (50.80)	.500 x .25 (12.70 x 6.35)	1.875 (47.62)	*2.937 (74.60)
	2.25 (57.15)			
	2.50 (63.50)			
	2.75 (69.85)			
750	2.437 (61.90)	.625 x .32 (15.87 x 7.94)	2.250 (57.15)	3.437 (87.30)
	2.500 (63.50)			
	2.750 (69.85)			
	2.937 (74.60)			
	3.000 (76.20)			
	3.250 (82.55)			
800	3.000 (76.20)	.750 x .38 (19.05 x 9.52)	2.625 (66.67)	4.437 (112.70)
	3.250 (82.55)			
	3.437 (87.30)			
	3.500 (88.90)			
	3.750 (95.25)			
	3.937 (100.00)			
	4.000 (101.60)			
	4.250 (107.95)			
900	4.000 (101.60)	1.000 x .50 (25.40 x 12.70)	3.625 (92.07)	5.437 (138.10)
	4.250 (107.95)			
	4.437 (112.70)			
	4.500 (114.30)			
	4.750 (120.65)			
	4.937 (125.40)			
	5.000 (127.00)			
	5.250 (133.35)			
1027	4.937 to 6.000 (125.40 to 152.40)	1.250 x .63 (31.75 x 15.87)	4.937 (125.40)	7.000 (177.80)
	6.250 to 6.625 (158.75 to 168.27)			
	6.750 to 6.875 (171.45 to 174.62)			
	7.000 (177.80)			
	1.500 x .50 (38.10 x 12.70)			
	1.500 x .44 (38.10 x 11.10)			

\* .625 x .13 keyway

**Dimensions inches (mm)**

Size	A	B	C	D	E	F	G	H	J			K	L
									Number	Thread	Depth		
720	5.00 (127.00)	7.125/7.123 (180.97/180.92)	4.88 (123.82)	3.56 (90.47)	.06 (1.57)	—	6.25 (158.75)	.06 x 45° (1.57 x 45°)	8*	.375-24	.75 (19.05)	.250-28	2.44 (61.90)
750	6.00 (152.40)	8.750/8.748 (222.25/222.20)	5.88 (149.22)	4.25 (107.95)	.06 (1.57)	1.25 (31.75)	7.00 (177.80)	.06 x 45° (1.57 x 45°)	8*	.500-20	1.00 (25.40)	.500-24	1.94 (49.20)
800	6.00 (152.40)	10.000/9.998 (254.00/253.95)	5.88 (149.22)	5.50 (139.70)	.06 (1.57)	1.25 (31.75)	8.94 (227.00)	.06 x 45° (1.57 x 45°)	8 @ 45°	.500-20	1.00 (25.40)	.500-24	1.94 (49.20)
900	6.38 (161.92)	12.000/11.997 (304.80/304.72)	6.25 (158.75)	6.38 (161.92)	.06 (1.57)	1.38 (34.92)	9.75 (247.65)	.06 x 45° (1.57 x 45°)	10 @ 36°	.625-18	1.25 (31.75)	.500-20	2.13 (53.97)
1027	6.63 (168.27)	15.000/14.997 (381.00/380.92)	6.50 (165.10)	9.00 (228.60)	.06 (1.57)	1.38 (34.92)	11.75 (298.45)	.13 x 45° (3.17 x 45°)	12 @ 30°	.625-18	1.00 (25.40)	.500-20	2.13 (53.97)

\* Six holes equally spaced at 60° plus two extra holes at 180°. Six hardened mounting screws are adequate for torque loads up to 3000 lb. ft. (4068 Nm) for model 720. Use eight hardened mounting screws for torque loads above these values. On model 750, six hardened mounting screws are adequate to handle torque rating.

# General Purpose Clutches

## SB/SBI

### Overrunning, Indexing, Backstopping Ball Bearing Supported, Sprag Clutches

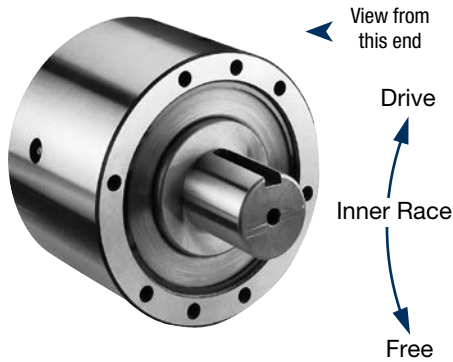

Right Hand rotation shown.  
(Left Hand opposite.)

Specify direction of rotation when ordering.

Standard clutches and all C/T clutches are oil lubricated. Grease lubrication is available for applications where maintenance is inadequate, or where higher inner race overrunning speeds are required. The ground O.D. of the outer race is designed as a pilot or mounting surface for attaching parts and is concentric with the bore. Tapped holes are provided in each end of the outer race for securing these parts to the clutches. Refer to Bore Sizes/Shaft Tolerances chart for mounting data, page 128.

For vertical mounting, contact Application Engineering.

#### Model SB

General purpose, ball-bearing clutches suitable for overrunning, backstopping and light to medium-duty indexing applications. They are oil lubricated and equipped with lip type seals. Grease is available. Increased speeds are possible with steel labyrinth seals.

#### C/T Sprag Models

C/T sprag clutches are ideal for applications with high speed outer race overrunning and low speed driving. Available with oil lubrication only.

#### Model SBI

Especially designed for **medium to heavy-duty** indexing applications, or applications in excess of 150 strokes/min. to provide the maximum in dependable, uniform, long life performance. They are oil lubricated and equipped with lip type seals. Grease is available.

#### Oil Lubricated Clutches

SB-500 through 1027 clutches are shipped from the factory with Mobil DTE Heavy Medium oil.

SB-500 through 1027 clutches are shipped from the factory with Mobil DTE Light oil.

#### Grease Lubricated Clutches

SB-500 through 1027 clutches are shipped from the factory packed with Fiske Brothers Lubriplate Low-Temp grease.

For further information, see *Installation and Maintenance Bulletin No. 2219, P-222-10 for the FSO series and No. 2213, P-222-6 for the HPI series.*

#### Typical Mounting Arrangement

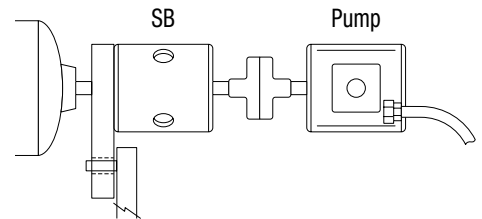

The Model SB clutches must be secured to the shaft by two set screws. For use in backstopping applications, see available torque arms on page 122. All fasteners are recommended to be grade 8 bolts.

## Specifications

Size	Torque Capacity* lb.ft. (Nm)	Maximum RPM								Resistance after run-in lb.ft. (Nm)	Lubrication		Shipping Weight lb. (kg)
		Standard Models				C/T Sprag Models					Oil or Grease	Oil only	
		Overrunning Speed				Overrunning Speed							
		Oil and Grease Lip Seals		Labyrinth Grease Seals		Overrunning Speed		Max. drive	Sprag lift-off		SB oz (ml)	SBI oz (ml)	
		Inner Race	Outer Race	Inner Race	Outer Race	Inner Race	Outer Race						
500	875 (1190)	2,500	800	3,000	800	2,500	4,000	1,000	1,200	.23 (.31)	.75 (22.0)	1.25 (35.0)	11.5 (5.3)
600	1,600 (2176)	2,200	750	2,400	750	2,200	3,600	1,000	1,200	.46 (.62)	1.75 (52.0)	3.00 (84.0)	21 (9.6)
700	4,000 (5440)	1,600	450	2,000	450	1,600	2,500	800	1,000	1.15 (1.56)	6.00 (168.0)	10.00 (280.0)	46 (21)
750	5,500 (7480)	1,000	650	1,800	650	1,000	1,800	650	800	3.75 (5.08)	7.00 (207.0)	13.00 (384.0)	91 (41.6)
800	10,800 (14688)	850	525	1,500	525	850	1,500	525	675	5.25 (7.12)	8.50 (251.0)	15.00 (444.0)	112 (51.2)
900	14,800 (20128)	700	500	1,350	500	700	1,350	500	650	6.25 (8.47)	11.50 (340.0)	16.00 (473.0)	171 (78.1)
1027	22,300 (30328)	500	375	1,100	375	500	1,100	375	475	10.00 (13.56)	16.00 (473.0)	32.00 (946.0)	275 (125.7)

**Note:** Check key and shaft stress before making final clutch selection since this may determine the maximum allowable drive torque capacity.

\*Any variations to bore, key seat, shaft length, etc. may change the torque capacity.

**Note:** OSHA requires that a stationary guard must enclose clutches with rotating projecting parts and operating seven (7) feet or less above the floor.

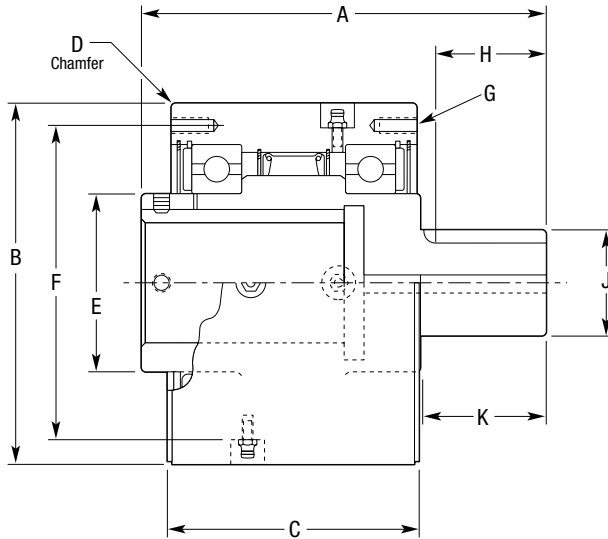

**Notes:**

Angle — oil hole to mounting bolt hole

- Model 500 = 45°
- 600 = 15°
- 700 = 0° or 30° (offset from center of outer race)
- 750 = 0° or 30°
- 800 = 0° or 45°
- 900 = 0° or 18°
- 1027 = 15°

Snap ring is located on the outboard side of the oil seal on Models 600 and larger. On model 500, snap ring is inboard of the oil seal.

**Bore sizes and keyseats††† inches (mm)**

Size	Bore Size	Keyseat	Bore Range	
			Min.	Max.
500	.875 (22.22)	3/16 x 3/32 (4.75 x 2.36)	.750 (19.05)	1.312 (33.32)
	1.312 (33.32)	1/4 x 3/32 (6.35 x 2.29)		
	1.250 (31.75)	1/4 x 1/8 (6.35 x 3.18)		
600	2.000 (50.80)	3/8 x 1/8 (9.52 x 3.18)	.937 (23.80)	2.250**† (57.15)
	1.937 (49.20)	1/2 x 1/4 (12.70 x 6.35)	1.875 (47.62)	3.250**† (82.55)
2.937 (74.60)	5/8 x 1/8 (15.87 x 3.18)			
75mm	20 x 4.9mm***			
80mm	22 x 5.4mm***			
750	2.437 (61.90)	5/8 x 5/16 (15.87 x 7.94)	2.250 (57.15)	3.437 (87.30)
	2.500 (63.50)	5/8 x 5/16 (15.87 x 7.94)		
	3.437 (87.30)	3/4 x 3/16 (19.05 x 4.75)		
800	3.000 (76.20)	3/4 x 3/8 (19.05 x 9.52)	2.625 (66.67)	4.437 (112.70)
	4.437 (112.70)	1 x 1/4 (25.40 x 6.35)		
900	100mm	28 x 6.4mm***	3.625 (92.07)	5.437 (138.10)
	4.000 (101.60)	1 x 1/2 (25.40 x 12.70)		
	5.437 (138.10)	1 x 1/4 (25.40 x 6.35)		
1027	4.937 (125.40)	1 1/4 x 5/8 (31.75 x 15.87)	4.937 (125.40)	7.000 (177.80)
	7.000 (177.80)	1 1/2 x 7/16 (38.10 x 11.10)		

\* 1/2 x 1/8 keyway.

\*\* 3/4 x 1/4 keyway.

\*\* For finished dimensions of keys supplied with the clutch, contact Formsprag.

\*\*\* Contact Formsprag for keyseat information.

† The "E" dimension is larger for this bore size.

††† For Bore Sizes/Shaft Tolerances, see page 128.

**Dimensions inches (mm)**

Size	A	B	C	D	E	F	G			H	J	K
							Number	Thread	Depth			
500	5.56 (141.22)	4.250/4.248 (107.95/107.90)	3.38 (85.85)	.06 x 45° (1.58 x 45°)	1.75 (44.45)	3.625 (92.07)	4 @ 90°	.312-24	.63 (15.87)	1.57 (39.88)	1.25 (31.75)	1.75 (44.45)
600	6.25 (158.75)	5.375/5.373 (136.53/136.47)	3.63 (92.20)	.06 x 45° (1.58 x 45°)	2.50 (63.50)	4.750 (120.65)	6 @ 60°	.312-24	.63 (15.87)	1.83 (46.48)	1.75 (44.45)	2.00 (50.80)
700	8.00 (203.20)	7.125/7.123 (180.97/180.92)	4.88 (123.95)	.06 x 45° (1.58 x 45°)	3.56 (90.42)	6.250 (158.75)	8†	.375-24	.75 (19.05)	2.33 (59.18)	2.75 (69.85)	2.50 (63.50)
750	9.75 (247.65)	8.750/8.748 (222.25/222.20)	5.88 (149.35)	.06 x 45° (1.58 x 45°)	4.25 (107.95)	7.000 (177.80)	8††	.312-24	.63 (15.87)	2.80 (71.12)	3.25 (82.55)	3.00 (76.2)
800	10.75 (273.05)	10.000/9.998 (254/253.95)	5.88 (149.35)	.06 x 45° (1.58 x 45°)	5.50 (139.70)	8.94 (227.08)	8 @ 45°			3.56 (90.42)	4.25 (107.95)	3.75 (95.25)
900	12.10 (307.34)	12.000/11.997 (304.80/304.72)	6.25 (158.75)	.06 x 45° (1.58 x 45°)	6.38 (162.05)	9.75 (247.65)	10 @ 36°			4.31 (109.47)	5.25 (133.35)	4.50 (114.30)
1027	13.38 (339.85)	15.000/14.997 (381/380.92)	6.50 (165.10)	.13 x 45° (3.30 x 45°)	9.00 (228.60)	11.75 (298.45)	12 @ 30°			5.14 (130.56)	6.25 (158.75)	5.50 (139.70)

**Notes:**

† Six holes equally spaced at 60° plus two extra holes at 180°. Six hardened mounting screws are adequate for torque loads up to 3,000 lb.ft. (4068 Nm). Use eight hardened mounting screws for torque loads above these values.

†† Six holes equally spaced at 60° plus two extra holes at 180°. Six hardened mounting screws are adequate for torque loads up to 5,100 lb.ft. (6915 Nm). Use eight hardened mounting screws for torque loads above these values.

# Special Purpose Clutches

## FSD/HBG

### Overrunning, Backstopping Ball Bearing Supported Sprag, High Torque Drawworks Clutches

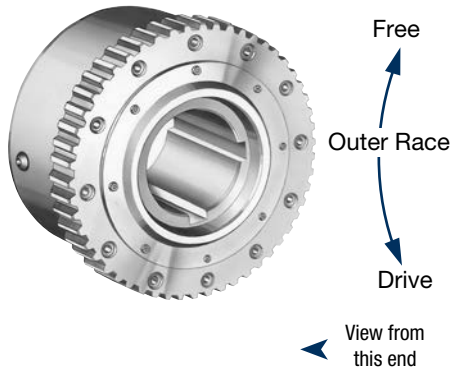

Left Hand rotation shown.  
(Right Hand opposite.)

Specify direction of rotation when ordering.

Drawworks clutches are designed for use with Hydromatic® brakes on drilling rigs. They are available over a range of torque capacities and provide reliable performance in original equipment or as a replacement for type C2 and type A clutches.

#### Model FSD-27 Sprag

Use with Hydromatic brakes having 6" or smaller shafts.

- Interchangeable with National Supply Company's model 703250-C2

#### Model FSD-65 Sprag

Use with Hydromatic brakes having 7.5" shafts.

- Directly interchangeable with other type A clutches

#### Model FSD-125 Sprag

Use with Hydromatic brakes having 7.5" shafts, can be substituted for type A clutches.

- For use with type A spider and sleeve

#### Model FSD-300 Sprag

Use with Hydromatic brakes having 9" shafts.

- Provides five times the torque capacity than type A clutches

For further information see for Installation & Maintenance Bulletin No. A-3031, P-222-19.

The Model HBG series are designed for use on Hydro-dynamic Brakes on drilling rigs, using Ramp & Roller Technology which offers better availability.

#### Model HBG-27MA Ramp & Roller

Use with Hydromatic brakes having 6.5" or smaller straight or tapered shafts.

- Interchangeable with National type C clutches

#### Model HBG-63MA Ramp & Roller

Use with Hydromatic brakes having 7.5" straight and tapered shafts.

- Interchangeable with National type A clutches

#### Model HBG-135MA Ramp & Roller

Use with Hydromatic brakes having 7.5" tapered and larger shafts.

- Interchangeable with National Type D-1

FSD and HBG clutches are shipped from the factory with Automatic Transmission fluid (ATF).

For further information see for Installation & Maintenance Manual P-1346-10.

### Specifications/spline data

Size	Torque Capacity lb.ft. (Nm)	Resistance after run-in lb.ft. (Nm)	Shipping Weight lb. (kg)	No. of Teeth	Pressure Pitch	Angle	Pitch Diameter in. (mm)	Major Dia. in. (mm)	Minor Dia. in. (mm)
FSD-27	27,000 (36,720)	10 (14)	185 (84)	40	3/6	30°	13.333 (338.66)	13.597/13.592 (345.36/345.23)	12.929 (328.40)
FSD-65	65,000 (88,400)	25 (35)	508 (231)	53	3/6	30°	17.666 (448.72)	17.929/17.915 (455.39/455.04)	17.263 (438.48)
FSD-125	125,000 (170,000)	30 (40)	615 (279.5)	53	3/6	30°	17.666 (448.72)	17.929/17.915 (455.39/455.04)	17.263 (438.48)
FSD-300	300,000 (408,000)	75 (100)	1,650 (750)	110	4/5	20°	27.500 (698.50)	27.900/27.890 (708.66/708.40)	27.000 (685.80)
HBG-27MA	27,000 (36,720)	—	265 (131)	40	3/6	30°	13.333 (338.66)	13.597/13.592 (345.36/345.23)	12.929 (328.40)
HBG-63MA	63,000 (85,680)	—	515 (255)	53	3/6	30°	17.666 (448.72)	17.929/17.915 (455.39/455.04)	17.263 (438.48)
HBG-135 MA	135,000 (183,600)	—	1,100 (544)	68	3/6	30°	22.666 (575.72)	22.929/22.924 (582.40/582.27)	22.217 (564.31)

### FSD-27 HBG-27MA

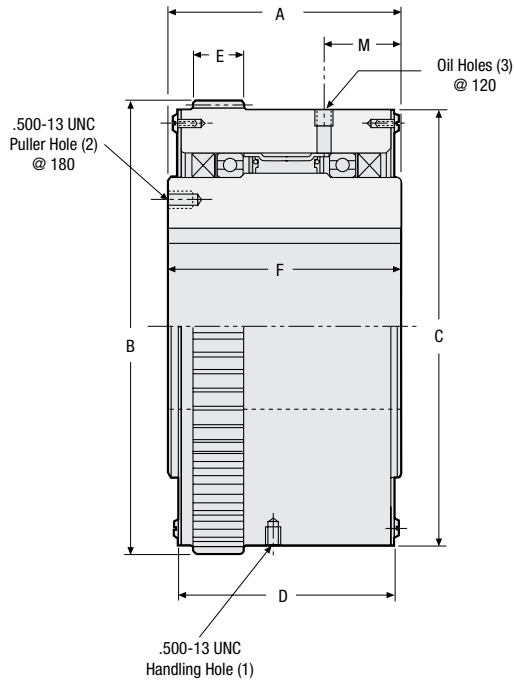

### FSD-65, -125, -300 HBG-63MA, -135MA

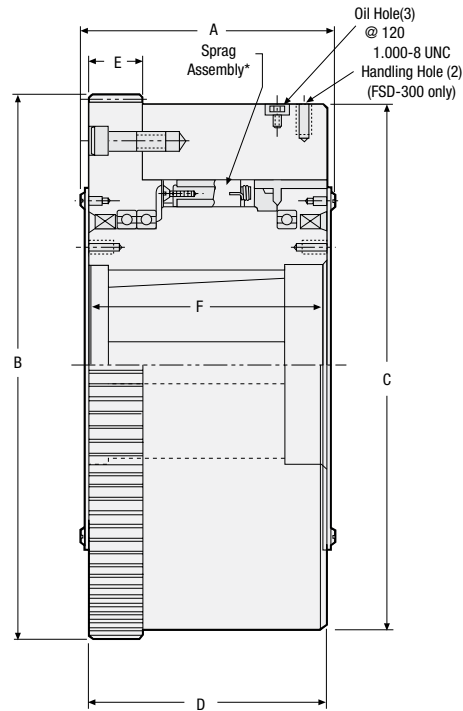

\* FSD-125 has two sprag assemblies.

### Standard bore sizes and keyseats\* inches (mm)

Size	Bore Diameter	Taper per ft. (per M)	Keyseat
27	6.00 (152.40)	None	1.25 x .83 (31.70 x 21.08)
63, 65	7.473/7.476 (189.81/189.89)	1.250" (3.175)	1.500/1503 x .89 (38.10/38.18 x 22.60)
125, 135	7.473/7.476 (189.81/189.89)	1.250" (3.175)	1.500/1.503 x .89 (38.10/38.18 x 22.60)
300	7.473/7.476 (189.81/189.89) 8.9745/8.9775 (227.95/228.03)	1.250" (3.175)	2.500/2.503 x .84 (63.50/63.57 x 21.34)

\* For Bore Sizes/Shaft Tolerances, see page 128.

### Dimensions inches (mm)

Size	A	B	C	D	E	F
FSD-27	7.00 (177.80)	13.597/13.592 (345.36/345.23)	12.896/12.866 (327.55/326.79)	6.43 (163.32)	1.50 (38.10)	7.00 (177.80)
FSD-65	10.31 (261.87)	17.929/17.915 (455.39/455.04)	17.230/17.200 (437.64/436.88)	9.81 (249.17)	2.40 (60.96)	9.72 (246.88)
FSD-125	13.13 (333.50)	17.929/17.915 (455.39/455.04)	17.230/17.200 (437.64/436.88)	12.63 (320.80)	2.40 (60.96)	12.49 (317.25)
FSD-300	12.62 (320.54)	27.900/27.890 (708.66/708.40)	26.980/26.960 (685.29/684.78)	12.12 (307.84)	2.69 (68.32)	12.06 (306.32)
HBG-27MA	7.00 (177.80)	13.597/13.592 (345.36/345.23)	13.03 (330.96)	7.00 (177.80)	1.50 (38.10)	7.00 (177.80)
HBG-63MA	8.75 (222.25)	17.929/17.915 (455.39/455.04)	17.34 (440.44)	8.75 (222.25)	1.88 (47.75)	8.75 (222.25)
HBG-135MA	10.00 (254.00)	22.929/22.924 (582.40/582.27)	22.09 (561.09)	10.00 (254.00)	2.50 (63.50)	10.00 (254.00)

# Special Purpose Clutches

## CDU

### Overrunning, Inline, Standby and Creep Drive Operation Ball Bearing Supported, Sprag Clutches

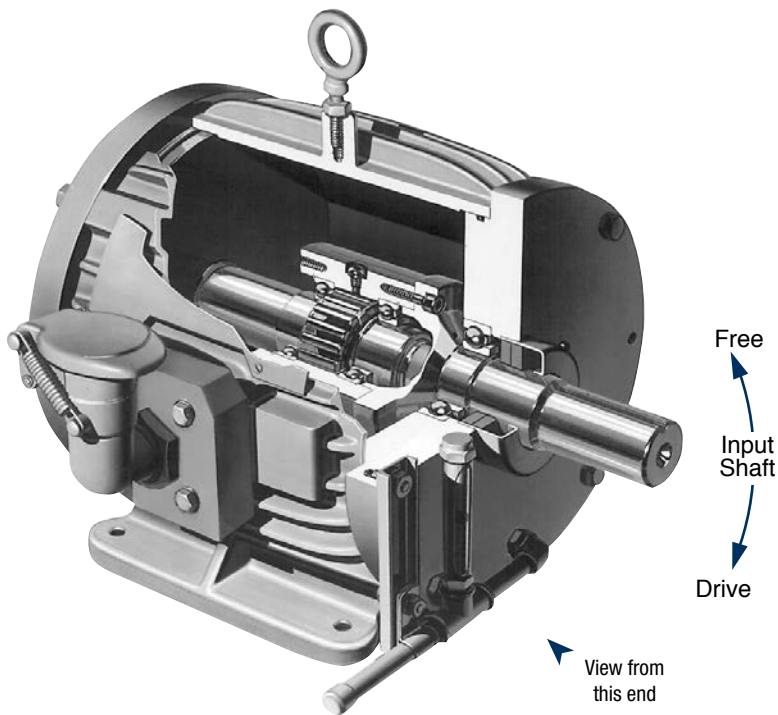

Right Hand rotation shown. (Left Hand opposite.)  
Specify direction of rotation when ordering.

Continuous drive units are intended for use in continuous overrunning applications where the system cannot be shut down for maintenance and for applications in extremely harsh and dusty environments such as coal handling systems.

A CDU consists of an FSO overrunning, sprag clutch installed in a foot-mounted housing which encloses a generous supply of oil. The large oil volume along with the high dissipation capability of the finned housing permits extended service periods between oil changes. An oil sight gauge is mounted on each CDU for quick and easy monitoring of the oil level. Oil can be added without stopping the machine. The entire unit is sealed. Grease barrier seals minimize contamination and wear of the oil seals in environments with abrasive material.

The overrunning clutch internal to the CDU-500 through 1051 is oil dipped at the factory but *must be filled to the proper level before operation.*

*For further information see Instruction and Maintenance Bulletin No. A-3038, P-222-23. Contact Formsprag application engineering department on indirect drive applications.*

## Sprag assemblies available

All CDUs have ultra-hard Formchrome® sprags which provide extra-long life, maximum wear resistance, and lower maintenance costs. Formchrome sprags, exclusive with Formsprag, are made by diffusing chromium into the surface of a hardened high carbon steel to form a chromium-carbide alloy. Models 500, 600 and 700 are equipped with PCE (Positive Continuous Engagement) sprags which are designed to overcome the effects of torsional vibration and high transient torque. C/T (Centrifugal Throw-out) sprags, which lift-off of the inner race, thereby eliminating overrunning wear, are available in all models.

## Features

### PCE Sprags

Help prevent clutch damage due to transient overloads or torsional vibrations

### Formchrome Sprags with 70 Rc Hardness

Maximum wear life for extended clutch service

### Large Oil Reservoir

Minimum maintenance (increased lubrication capacity)

### Grease Barrier Seals

Protects oil seals from dusty and abrasive conditions providing extended seal life

### Oil Fill and Drain Ports

Ease of maintenance

### Breather

Pressure equalization without affecting oil seals

### Foot Mounted Unit

Stand alone unit provides for easy access, installation and removal without disturbing equipment

### Optional Centrifugal Throw-out (C/T) Sprag Design

Provides extended clutch life by eliminating rubbing contact of sprags during overrunning portion of duty cycle

### Oil Sight Gauge

Provides a convenient method for checking oil level with CDU in operation



### Applications

The CDUs in this catalog are designed for inline drives only. Applications for these self-contained foot-mounted continuous drive units are creep drives, turning gear drives, dual drives, energy recovery drives, and standby drives. C/T may be used in installations such as creep drives and turning gear drives where the drive speed is well below the overrunning speed.

*For CDU installations requiring offset drives, contact Formsprag.*

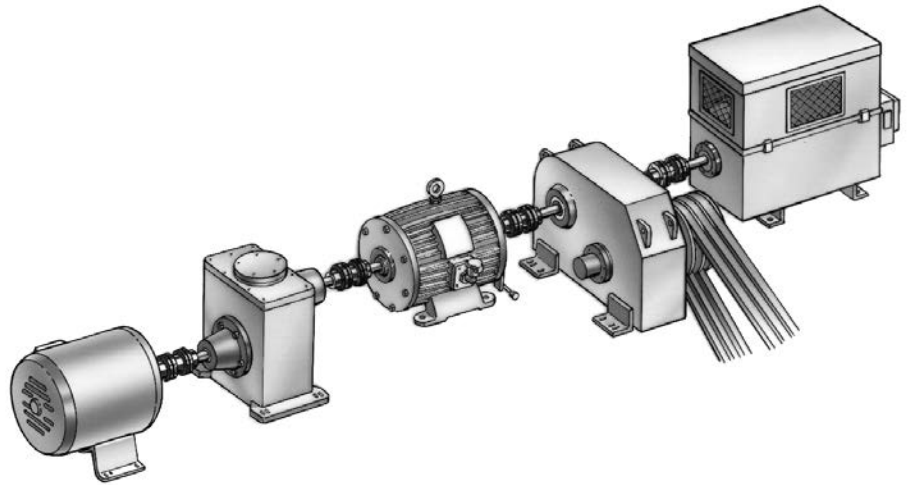

**Creep (Low) Speed Drive**

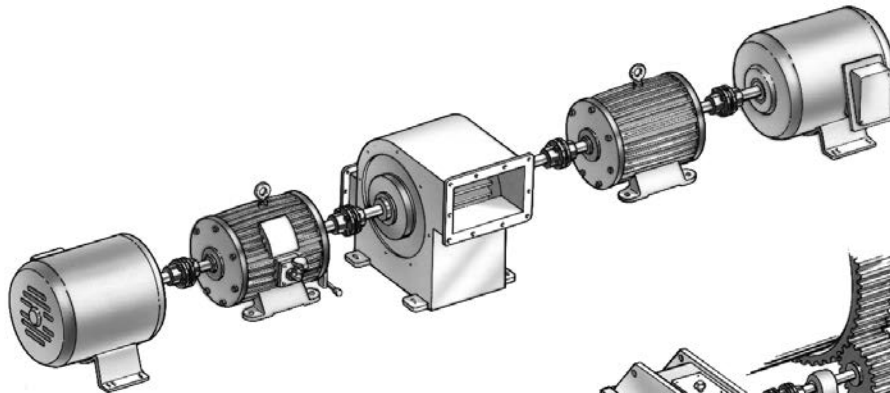

**Dual Drive**

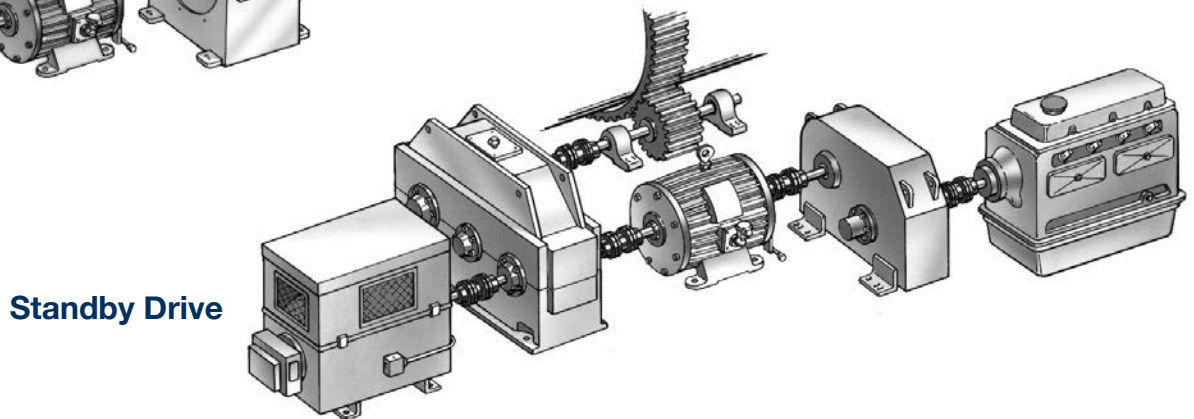

**Standby Drive**

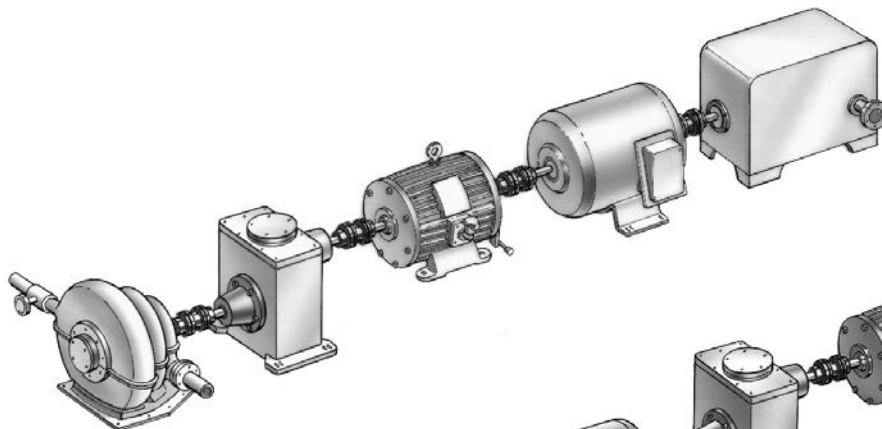

**Energy Saving Drive**

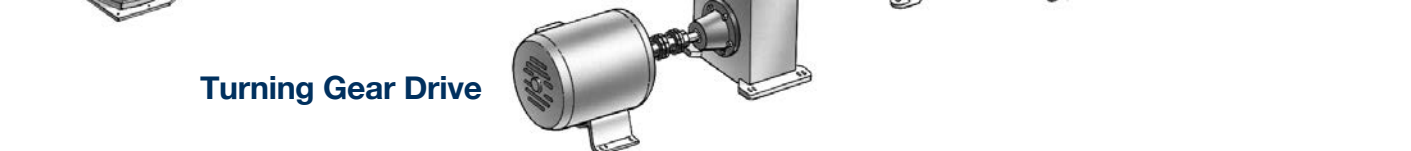

**Turning Gear Drive**

# Special Purpose Clutches

## CDU

### Specifications

Size	Torque Capacity lb.ft. (Nm)	Maximum RPM					Resistance after run-in lb.ft. (Nm)	Shipping Weight lb. (kg)
		Standard Model		C/T Model				
		Driving	Overrunning	Driving	Sprag lift-off	Overrunning		
500	1,175 (1593)	3,600	3,600	1,000	1,200	3,600	.45 (.61)	125 (57)
600	2,250 (3051)	3,600	3,600	1,000	1,200	3,600	.90 (1.22)	135 (61)
700	5,000 (6780)	2,000	2,000	800	1,000	2,000	2.13 (2.89)	529 (240)
750	7,000 (9492)	1,800	1,800	650	800	1,800	7.50 (10.16)	570 (259)
800	13,000 (17628)	1,500	1,500	525	675	1,500	10.50 (14.23)	836 (389)
900	18,000 (24408)	1,350	1,350	500	650	1,350	12.50 (16.94)	890 (404)
1027	27,000 (36600)	1,100	1,100	375	475	1,100	20.00 (27.10)	1,289 (584)
1051	45,000 (61010)	1,100	1,100	375	475	1,100	24.00 (32.52)	1,339 (607)

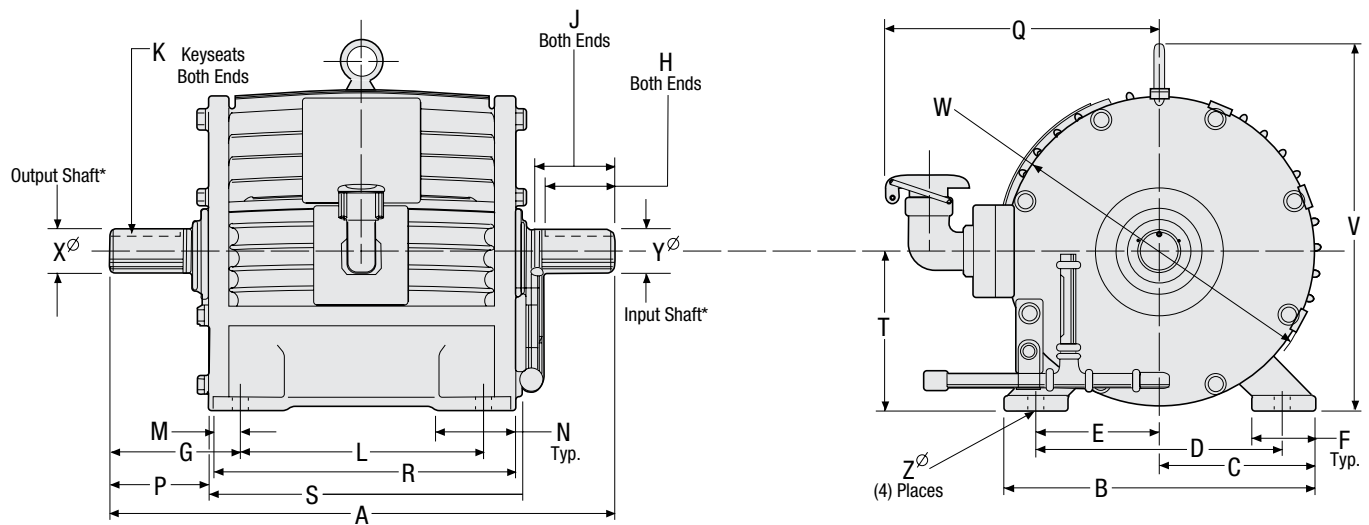

\*For C/T models, the input and output shaft diameters are reversed.

### Dimensions inches (mm)

Size	A	B	C	D	E	F	G	L	M	N	P	Q	R	S	T	V	W	Z
500	18.00 (427.20)	10.50 (266.70)	5.25 (133.35)	8.50 (215.90)	4.25 (107.95)	2.00 (50.80)	5.50 (139.70)	7.00 (177.80)	.75 (19.05)	4.25 (107.95)	4.19 (106.43)	9.38 (238.25)	8.50 (215.90)	10.62 (269.75)	5.25 (133.35)	13.38 (339.85)	10.75 (273.05)	.406 (10.31)
600	19.25 (488.95)	10.50 (266.70)	5.25 (133.35)	8.50 (215.90)	4.25 (107.95)	2.00 (50.80)	6.12 (155.45)	7.00 (177.80)	.75 (19.05)	4.25 (107.95)	5.38 (136.65)	9.38 (238.25)	8.50 (215.90)	10.62 (269.75)	5.25 (133.35)	13.38 (339.85)	10.75 (273.05)	.406 (10.31)
700	26.75 (679.45)	15.75 (400.05)	7.88 (200.15)	12.50 (317.50)	6.25 (158.75)	3.25 (82.55)	7.38 (187.45)	12.00 (304.80)	1.50 (38.10)	3.12 (79.25)	5.78 (146.81)	12.25 (311.15)	15.00 (381.00)	15.19 (385.83)	8.00 (203.20)	19.00 (482.60)	16.38 (416.05)	.656 (16.66)
750	28.25 (717.55)	15.75 (400.05)	7.88 (200.15)	12.50 (317.50)	6.25 (158.75)	3.25 (82.55)	8.13 (206.50)	12.00 (304.80)	1.50 (38.10)	3.12 (79.25)	6.53 (166.81)	12.25 (311.15)	15.00 (381.00)	15.19 (385.83)	8.00 (203.20)	19.00 (482.60)	16.38 (416.05)	.656 (16.66)
800	34.00 (863.60)	19.75 (501.65)	9.88 (250.95)	16.00 (406.40)	8.00 (203.20)	3.75 (95.25)	10.12 (257.05)	13.75 (349.25)	1.50 (38.10)	3.50 (88.90)	8.12 (206.25)	14.12 (358.65)	16.75 (425.45)	17.75 (450.85)	10.00 (254.00)	23.25 (590.55)	20.50 (520.70)	.812 (20.63)
900	36.00 (914.50)	19.75 (501.65)	9.88 (250.95)	16.00 (406.40)	8.00 (203.20)	3.75 (95.25)	11.12 (282.45)	13.75 (349.25)	1.50 (38.10)	3.50 (88.90)	9.12 (231.65)	14.12 (358.65)	16.75 (425.45)	17.75 (450.85)	10.00 (254.00)	23.25 (590.55)	20.50 (520.70)	.812 (20.63)
1027	41.00 (1041.40)	22.00 (558.80)	11.00 (279.40)	18.00 (427.20)	9.00 (228.60)	4.00 (101.60)	12.25 (311.15)	16.50 (419.10)	1.50 (38.10)	4.00 (101.60)	11.00 (279.40)	15.00 (381.00)	19.50 (495.30)	19.00 (482.60)	11.00 (279.40)	26.19 (665.23)	22.25 (565.15)	.812 (20.63)
1051	41.00 (1041.40)	22.00 (558.80)	11.00 (279.40)	18.00 (427.20)	9.00 (228.60)	4.00 (101.60)	12.25 (311.15)	16.50 (419.10)	1.50 (38.10)	4.00 (101.60)	11.00 (279.40)	15.00 (381.00)	19.50 (495.30)	19.00 (482.60)	11.00 (279.40)	26.19 (665.23)	22.25 (565.15)	.812 (20.63)

Size	X* Output Shaft Dia.	Y* Input Shaft Dia.	Both Ends		
			K Keyseats	J Usable Shaft Length	H Effective Keyseat Length
500	1.437/1.436 (36.49/36.47)	1.500/1.499 (38.10/38.07)	3/8 x 3/16 (9.53 x 4.76)	2.75 (69.85)	2.50 (63.50)
600	1.687/1.686 (42.85/42.82)	1.750/1.749 (44.45/44.42)	3/8 x 3/16 (9.53 x 4.76)	3.38 (85.85)	3.00 (76.20)
700	3.000/2.999 (76.20/76.17)	3.062/3.061 (77.77/77.75)	3/4 x 3/8 (19.05 x 9.65)	4.50 (114.30)	4.00 (101.60)
750	3.000/2.999 (76.20/76.17)	3.062/3.061 (77.77/77.75)	3/4 x 3/8 (19.05 x 9.65)	5.38 (136.65)	4.75 (120.65)
800	3.937/3.936 (100.00/99.97)	4.000/3.999 (101.60/101.57)	1 x 1/2 (25.40 x 12.70)	6.25 (158.75)	5.00 (127.00)
900	3.937/3.936 (100.00/99.97)	4.000/3.999 (101.60/101.57)	1 x 1/2 (25.40 x 12.70)	7.25 (184.15)	6.00 (152.40)
1027	5.376/5.375 (136.53/136.50)	5.437/5.436 (138.10/138.07)	1 1/4 x 5/8 (31.75 x 16.00)	8.63 (219.20)	7.75 (196.85)
1051	5.376/5.375 (136.53/136.50)	5.437/5.436 (138.10/138.07)	1 1/4 x 5/8 (31.75 x 16.00)	8.63 (219.20)	7.75 (196.85)

\* For C/T models, the input and output shaft diameters are reversed.

# Special Purpose Clutches

## RL<sup>®</sup> (Reverse-Locking)

Backstopping, Bi-directional / Reverse-locking Ball Bearing Supported, Sprag Clutches

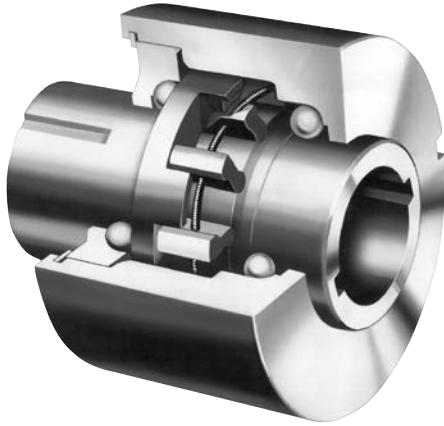

Available in six sizes, the Formsprag RL Clutch is a sprag type no-back which permits transmission of driving torque from input to output shaft in both directions of rotation, but restrains any feedback torque of the driven load from rotating the output shaft in either direction.

The RL Clutch is extremely simple in design and has a minimum number of moving parts. The outer race diameter is the same size as standard bearing dimensions, thus simplifying mounting and providing maximum strength in the assembly.

### Model RL-47A through RL-160A

Models RL-47A through RL-160A are larger units applicable in an extensive torque capacity range. These models require lubrication.

## Operating Principle

With the **outer race** held in a stationary or fixed position, torque is transmitted as follows:

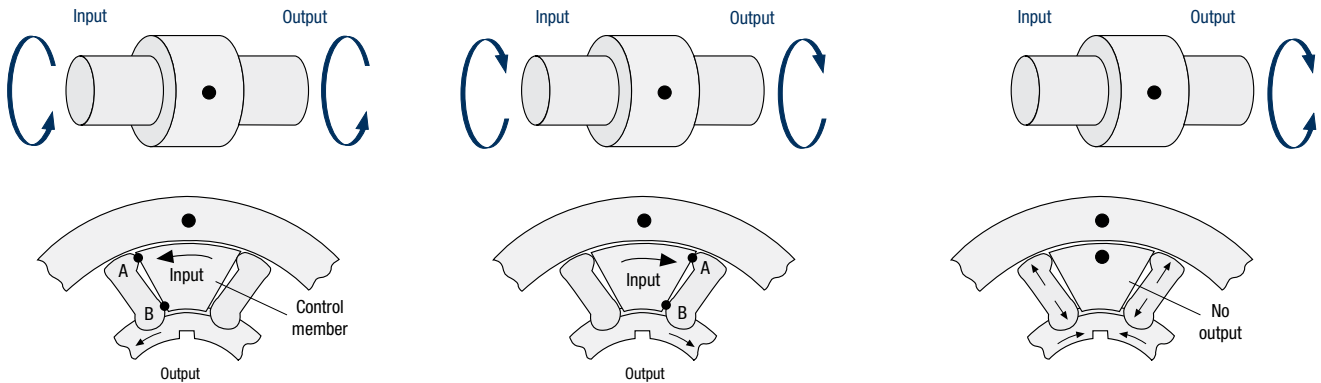

The control member projects between each pair of opposing sprags and when driving torque is applied to it, each projection first contacts a sprag at point "A" to disengage the sprag from the **outer race**. Then, the **control member** drives against the sprag at point "B" to transmit driving torque directly to the **output member**.

When input torque is reversed, the control member rotates a maximum of 6° to release the opposing set of sprags and then again drives the **output member** through point "B" on these sprags.

Any feedback torque from the **output member** is instantly stopped by the wedging of sprags between the fixed outer race and the **output member**—feedback torque never reaches the **control member**.

### Applications

Due to the versatility of this device, it can perform a number of application functions other than the standard positive positioning or no-back type application. Generally, the mounting arrangement used determines which function may be obtained. The RL clutch has been used successfully in the following applications:

- Torque releasing (partial, single, or multiple revolution)
- Selective direction overrunning
- Dual drive (two-speed drive)
- Selective direction backstopping

Additional information concerning these applications is available upon request.

### Design Advantages

- **Sprag-type design** — A complement of sprags arranged in opposing pairs insure that multiple contact surfaces always engage the outer race when feedback or back stopping conditions exist.
- **No backlash** — There is no backlash on the output shaft because sprags are in constant contact between the output member and the outer race. Any movement or torque applied to the output shaft results in instantaneous wedging of the sprags.
- **Wind-up** — Backlash of the output member with respect to the outer race is zero. However, when a feedback torque is applied to the output member, torsional wind-up will occur. Wind-up is approximately 2° when the feedback torque is equal to the rated capacity of the clutch.
- **High operating speeds** — Driving torque is transmitted in both directions of rotation at driving speeds ranging up to 1800 rpm by standard RL sprag type no-backs.
- **Equalized radial loading** — There are many equally spaced sprags contacting the outer race when feedback conditions exist to equalize radial loading and provide strong holding torque even against heavy feedback.

- **Broad temperature range** — Formsprag RL reverse-locking clutches may be operated over a wide temperature range. Either grease or oil lubrication may be used. At extreme temperatures (usually below 20°F or above 150°F) the Formsprag application engineering department should be consulted for specific lubrication and metallurgical recommendations.

### Other Considerations

**Radial and thrust loads.** The RL clutch is not designed to take radial or thrust loads. When such loads are present due to misalignment, gearing, sprockets, etc., external bearings should be utilized to accommodate these loads so that they will not be transferred to the clutch.

**Alignment.** In shaft to shaft connections the angular alignment of the shafts must be within .001" per inch of shaft length. Parallel alignment must be within .001" per inch of nominal shaft diameter. These figures are maximum and should not be exceed as it will result in extreme loading on the clutch.

**Overhauling loads.** Operating an RL clutch under overhauling load conditions (i.e., lowering a load with a crane) will occasionally result in a condition called "chatter." As the control fingers release the sprags, the load is momentarily unsupported and will accelerate the output member faster than the input member. The sprags will then arrest the load until continued motion of the input once again releases the sprags. The RL clutch, within its capacity, can arrest temporary overhauling loads, but it should not be subjected to continuously acting loads of this type. Such overhauling loads cause severe shock loading and also dissipate excessive energy through the RL clutch. This may have adverse effects on performance and life.

Continuously acting overhauling loads may be controlled by a suitable friction device (i.e., brake) which absorbs and diverts the dynamic torque and energy

from the RL clutch which holds the load in position. For such applications Formsprag should be consulted. Prototyping is recommended to determine the magnitude of the overhauling load and the method of using a friction device to control it.

**Breakaway torque.** When torque has caused the sprags to wedge between the socket member and the outer race, the control member fingers must disengage the sprags before driving can be resumed. This torque load can occur in response either to a load torque or an inertia torque. It is important that designers are aware of these inherent characteristics so that they may be considered and provided for in the design.

Input driving torque must always be sufficient to overcome any breakaway torques that may be present.

Breakaway torque may be due to one of three types:

1. Opposing load where the input drives against an output torque load.
2. Aiding load where the input torque is in the same direction as the output torque load.
3. Retained torque which is due to the internal resistance of the sprags after they have been wound up by the load and load is subsequently removed.

The breakaway torque may be as high as 25% more than the total torque to which the clutch has been loaded. For applications of this type consult Formsprag Application Engineering.

**Lost motion.** When the control element is in a neutral non-driving position, lost motion or lash of 2° to 3° in either direction of rotation from the neutral position will be required in order to disengage the sprags and permit drive.

*Contact Formsprag application engineering department for specific information.*

# Special Purpose Clutches

## RL

### Selection

For the proper selection of an RL clutch, all possible torques that the clutch may be subjected to must be taken into consideration. The following procedure should be adhered to, to insure that the correct clutch is selected for a given application.

1. Determine torque requirements:
  - a. Determine load torque. If cyclic, use maximum value.
  - b. Determine additional torques due to brakes, friction, other machine functions, etc.
  - c. Determine inertia torque due to the acceleration or deceleration of the load. This value is dependent on  $WR^2$  of the load and operating speed. See Technical Data.
2. Apply service factor from the table to the sum of all of the above torques involved in the system and select clutch from engineering data table.
3. Check operating speeds, available bores, and dimensional data of the clutch.
4. Check attachment data regarding mating elements in the system.
5. If all the above conditions are satisfactory, specify and order clutch by its model number.

### Service factors

Type of load	Factor
Gradually applied—light shock with inertia torque of less than 50% of the driven load torque	1.5 – 2.0
Suddenly applied—moderate shock with inertia torque of 50% to 100% of driven load torque.	2.0 – 2.5
Suddenly applied—heavy shock with inertia torques 100% to 200% of driven load torque.	3.0 – 3.5
Suddenly applied—extreme shock with inertia torques in excess of 200% of driven load torque.	4.0 – 6.0

### Specifications

Size	Nominal Shaft Diameter in. (mm)	Torque Capacity lb.in. (Nm)	Drag After Break-in* lb.in. (Nm)	Maximum Operating *Speed** RPM	Shipping Weight lb. (kg)
RL-35A	0.374 (9.5)	96 (10.8)	1.0 (0.11)	1800	0.33 (0.14)
RL-47A	.500 (12.7)	300 (34)	1.0 (.11)	1800	.95 (.4)
RL-72A	1.000 (25.4)	2400 (271)	2.0 (0.22)	1800	2.5 (1.1)
RL-90A	1.25 (31.75)	4,800 (542)	4.9 (.55)	1800	4.6 (2.0)
RL-115A	1.500 (38.1)	8,500 (963)	5.0 (.56)	1200	8.9 (4.0)
RL-130A	2.000 (50.8)	18000 (2040)	10.0 (1.13)	1200	13.3 (6.0)
RL-160A	2.500 (63.5)	26,500 (3003)	20.0 (2.26)	900	22.9 (10.4)

\* Break-in is equivalent to 24 hours of operation under ordinary circumstances.

\*\* Maximum driving speed permissible with grease pack if inertia torque as determined by selection procedure does not exceed rated torque.

### Technical data

Clutch torque based on speed and horsepower:

$$T = \frac{HP \times 63,000}{N}$$

Clutch torque due to dynamic loading:

$$T = .000407 (WR^2) N^2$$

Where:

- HP = Horsepower
- T = Torque, lb. in.
- N = Operating speed, RPM
- $WR^2$  = Effective inertia of load, lb.in.<sup>2</sup>

### Installation

The outside diameters of clutches are made to standard ball bearing dimensions. The RL should be mounted in the bore of a housing of sufficient length to accommodate a ball bearing on each side of the clutch. These bearings provide supports, maintain alignment, and should be designed to carry any radial and/or thrust loads imposed on the input and output shafts.

Snap rings or a shoulder should be provided on the input and output shafts, to insure that any thrust loads which may be imposed on the shafts will be absorbed by the customer-provided bearings.

Care should be taken in the location of snap ring grooves, so that shafts do not rest against each other or their keys do not impose thrust loads on the snap rings in the bore of the clutch.

### Lubrication

**Grease.** Formsprag RL clutches are lubricated at the factory with Lubriplate Low-Temp, a product of Fiske Brothers Refining Company. For temperatures below +20°F., or above 150°F. ambient consult Formsprag Application Engineering.

**Oil.** In applications where oil lubrication is to be used, factory supplied lubricant should be completely flushed from the clutch before installation. Use Mobil D.T.E. Heavy, Medium or any equivalent grade of good SAE-20 oil with high viscosity index (90VI min. 300 SSU at 100°F, 53 SSU at 210°F.)

RL-47A through 160A clutches are shipped from the factory packed with Fiske Brothers Lubriplate Low-Temp grease.

*For further mounting and maintenance information, see Installation and Maintenance Bulletin No. 4501, P-222-26.*

## RL-35A

## RL-47A through RL-160A

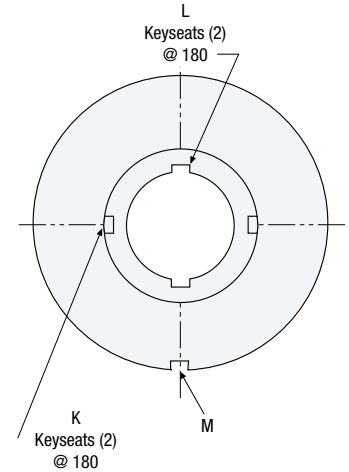
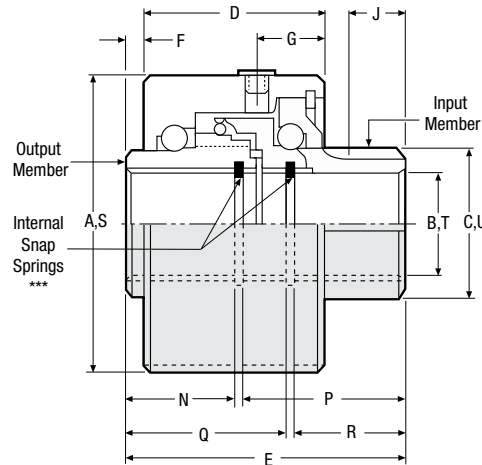
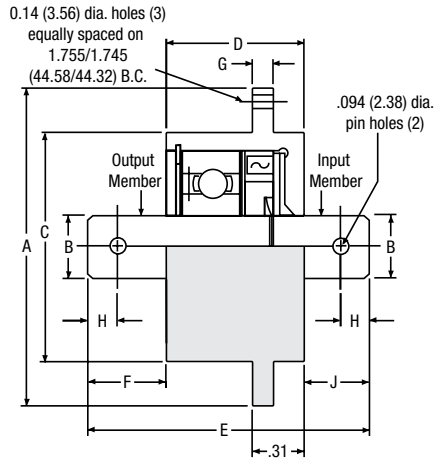

### Dimensions inches (mm)

Size	A	B	C	*D*	*E*	**F**	*G*	H	*J*
RL-35A	2.005/1.995 (50.93/50.67)	.3742/.3738 (9.505/9.495)	1.378/1.377 (35.00/34.96)	.843 (21.93)	1.75 (44.45)	.500 (12.70)	.0625 (1.588)	.1875 (4.763)	.4063 (10.32)
RL-47A	1.8504/1.8499 (47.000/46.987)	.500/.501 (12.700/12.725)	.783/.782 (19.89/19.86)	1.563 (39.70)	2.125 (53.98)	.031 (.787)	.688 (17.48)		.438 (11.13)
RL-72A	2.8346/2.8341 (71.999/71.986)	1.000/1.001 (25.400/25.425)	1.376/1.375 (34.95/34.93)	1.719 (43.66)	2.625 (66.68)	.156 (3.96)	.850 (21.59)		.625 (15.88)
RL-90A	3.5433/3.5428 (89.999/89.987)	1.252/1.251 (31.800/31.775)	1.850/1.849 (46.990/46.964)	2.287 (58.089)	3.11 (78.994)	0.031 (0.787)	1.000 (25.40)		0.750 (19.05)
RL-115A	4.5276/4.5271 (115.001/114.988)	1.500/1.501 (38.100/38.125)	2.001/2.000 (50.83/50.80)	2.281 (57.94)	3.141 (79.78)	.031 (.787)	.875 (22.23)		.688 (17.48)
RL-130A	5.1181/5.1173 (129.999/129.979)	2.000/2.001 (50.800/50.825)	2.845/2.844 (72.26/72.24)	2.828 (71.83)	4.172 (105.97)	.031 (.787)	1.00 (25.40)		1.031 (26.19)
RL-160A	6.2992/6.2982 (159.999/159.974)	2.500/2.501 (63.500/63.525)	3.876/3.875 (98.45/98.43)	3.094 (78.59)	4.719 (119.86)	.031 (.787)	1.00 (25.40)		.937 (23.80)

\* ± .010 (.254) except RL-35A

\*\* ± .020 (.508) except RL-35A

\*\*\* Inside diameter of snap rings is larger than the bore size

### Recommended Housing and Shaft Dimensions inches (mm)

Size	S Housing Bore	T Shaft Dia.	U Bore Dia.	Key Engagement Lengths		Shaft Engagement Lengths		N	R	Q	P
				Keyseats K	L	M					
RL-47A	1.8514/1.8520 (47.025/47.041)	.499/.498 (12.67/12.65)	.7833/.7838 (19.896/19.908)	3/32 x 3/64 (2.38 x 1.19)	3/32 x 3/64 (2.38 x 1.19)	1/8 x 1/16 (3.18 x 1.59)	.781 (19.84)	.813 (20.65)	1.156 (29.36)	1.188 (30.18)	
RL-72A	2.8356/2.8362 (72.024/72.039)	.999/.998 (25.38/25.35)	1.3763/1.3768 (34.958/34.971)	5/32 x 5/64 (3.97 x 1.98)	5/32 x 5/64 (3.97 x 1.98)	1/8 x 1/16 (3.18 x 1.59)	1.000 (25.40)	1.000 (25.40)	1.469 (37.31)	1.469 (37.31)	
RL-90A	3.5443/3.5451 (90.025/90.046)	1.250/1.249 (31.875/31.725)	1.8503/1.8510 (46.997/47.015)	3/16 x 3/32 (4.76/2.38)	3/16 x 3/32 (4.76/2.38)	3/16 x 3/32 (4.76/2.38)	1.250 (31.75)	1.250 (31.75)	1.770 (44.96)	1.770 (44.96)	
RL-115A	4.5286/4.5294 (115.026/115.047)	1.499/1.498 (38.07/38.05)	2.0013/2.0020 (50.833/50.851)	1/4 x 1/8 (6.35 x 3.18)	1/4 x 1/8 (6.35 x 3.18)	1/4 x 1/8 (6.35 x 3.18)	1.188 (41.27)	1.188 (41.28)	1.781 (45.24)	1.781 (45.24)	
RL-130A	5.1191/5.1201 (130.025/130.051)	1.999/1.998 (50.77/50.75)	2.8453/2.8463 (72.271/72.296)	5/16 x 5/32 (7.93 x 3.96)	5/16 x 5/32 (7.93 x 3.96)	1/4 x 1/8 (6.35 x 3.18)	1.635 (41.27)	1.635 (41.27)	2.375 (60.33)	2.375 (60.33)	
RL-160A	6.3002/6.3012 (160.025/160.050)	2.499/2.498 (63.48/63.45)	3.8763/3.8775 (98.458/98.489)	1/2 x 1/4 (12.70 x 6.35)	1/2 x 1/4 (12.70 x 6.35)	1/4 x 1/8 (6.35 x 3.18)	1.875 (47.62)	1.875 (47.62)	2.688 (68.28)	2.688 (68.28)	

# Backstopping Clutches

## RSBW

### Backstopping Sleeve Bearing Supported, Sprag Clutches



Model RSBW is a DC sprag type back-stop. It is self-contained, centered by plain bearings for low rotational speeds and sealed using shield protected O-Rings.

Unit is shipped grease lubricated ready for installation in either a horizontal or vertical position.

Primarily used as a backstop, this model provides high torque capacity with a minimum space requirement.

A bolt, secured to a fixed part of the machine and passing through the slot in the torque arm, provides the rotational stop. Radial clearance on this bolt should be equal to 1% of the slot width. The torque arm must not be rigidly mounted.

### Specifications

Size	Torque Capacity lb.ft. (Nm)	Overrunning Speed Max. RPM Inner Race	Lubrication	Shipping Weight lb. (kg)
20	276 (375)	400	Grease	4.5 (2)
25	447 (606)	400	Grease	5.73 (2.6)
30	447 (606)	400	Grease	5.51 (2.5)
35	447 (606)	400	Grease	5.29 (2.4)
40	956 (1295)	300	Grease	10.14 (4.6)
45	956 (1295)	300	Grease	9.92 (4.5)
50	956 (1295)	300	Grease	9.92 (4.5)
55	956 (1295)	300	Grease	9.70 (4.4)
60	1,882 (2550)	250	Grease	14.33 (6.5)
70	1,882 (2550)	250	Grease	14.11 (6.4)
80	3,598 (4875)	200	Grease	21.83 (9.9)
90	3,598 (4875)	200	Grease	21.61 (9.8)

### Typical Mounting Arrangement

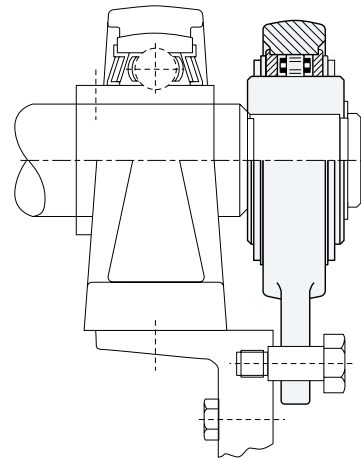

The Model RSBW clutches must be axially restrained on the shaft to avoid binding of the torque arm.



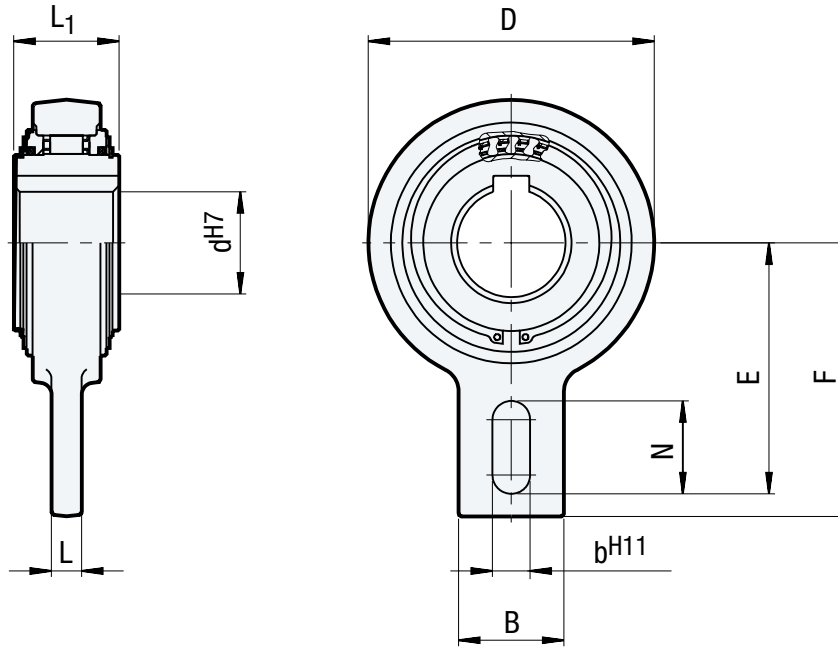

**Dimensions** inches (mm)

Size	D	L <sub>1</sub>	F	E	B	N	L	b <sup>H11</sup>
20	4.17 (106)	1.38 (35)	4.45 (113)	4.04 (102.5)	1.57 (40)	1.38 (35)	0.59 (15)	0.71 (18)
25	4.17 (106)	1.89 (48)	4.45 (113)	4.04 (102.5)	1.57 (40)	1.38 (35)	0.59 (15)	0.71 (18)
30	4.17 (106)	1.89 (48)	4.45 (113)	4.04 (102.5)	1.57 (40)	1.38 (35)	0.59 (15)	0.71 (18)
35	4.17 (106)	1.89 (48)	4.45 (113)	4.04 (102.5)	1.57 (40)	1.38 (35)	0.59 (15)	0.71 (18)
40	5.20 (132)	2.05 (52)	4.92 (125)	4.53 (115)	2.36 (60)	1.38 (35)	0.59 (15)	0.71 (18)
45	5.20 (132)	2.05 (52)	4.92 (125)	4.53 (115)	2.36 (60)	1.38 (35)	0.59 (15)	0.71 (18)
50	5.20 (132)	2.05 (52)	4.92 (125)	4.53 (115)	2.36 (60)	1.38 (35)	0.59 (15)	0.71 (18)
55	5.20 (132)	2.05 (52)	4.92 (125)	4.53 (115)	2.36 (60)	1.38 (35)	0.59 (15)	0.71 (18)
60	6.34 (161)	2.13 (54)	5.51 (140)	5.12 (130)	2.76 (70)	1.38 (35)	0.59 (15)	0.71 (18)
70	6.34 (161)	2.13 (54)	5.51 (140)	5.12 (130)	2.76 (70)	1.38 (35)	0.59 (15)	0.71 (18)
80	7.48 (190)	2.76 (70)	6.50 (165)	5.91 (150)	2.76 (70)	1.77 (45)	0.79 (20)	0.98 (25)
90	7.48 (190)	2.76 (70)	6.50 (165)	5.91 (150)	2.76 (70)	1.77 (45)	0.79 (20)	0.98 (25)

**Bore sizes and keyseats**

inches (mm)

Size	d <sup>H7</sup> Bore Size	Keyseat*
20	0.78 (20)	(6 X 2.8)
25	0.98 (25)	(8 X 3.3)
30	1.18 (30)	(8 X 3.3)
35	1.38 (35)	(10 X 3.3)
40	1.57 (40)	(12 X 3.3)
45	1.77 (45)	(14 X 3.8)
50	1.97 (50)	(16 X 4.3)
55	2.17 (55)	(16 X 4.3)
60	2.36 (60)	(18 X 4.4)
70	2.76 (70)	(20 X 4.9)
80	3.15 (80)	(22 X 5.4)
90	3.54 (90)	(25 X 5.4)

\* For keyseat sizes see DIN 6885.1 table on page 129.

# Backstopping Clutches

---

## HSB (High Speed Backstops)

Backstopping Ball Bearing Supported, Sprag Clutches



### Combination sprag clutch and oil reservoir Holdback conveyors and reducers

HSB units are intended for use as backstops on the high speed shaft or intermediate shaft of a reducer, and as holdbacks on the head shaft of conveyors. They use standard clutches with the addition of the oil reservoir. The oil reservoir is an aluminum casting with cooling fins. HSB models have a spacer replacing the seal at the reservoir end to permit free oil flow between clutch and reservoir. The reservoir has a flush oil sight gauge and a filtered breather. Refer to Bore Sizes/Shaft Tolerance chart for mounting data, page 67. Standard keys supplied by Formsprag at no additional charge for models 750 through 1027.

A torque arm is required to prevent the outer race and reservoir from rotating, see page 126.

The FSO-400 through 700 and FS-750 through 1027 clutch assemblies that are used to make up the HSB series clutches are shipped from the factory with Mobil DTE Heavy Medium oil, but must be filled to the proper level before operation.

*For further information, see Installation and Maintenance Bulletin No. 2214, P-222-7.*

### Specifications

Size	Torque Capacity lb.ft. (Nm)	Overrunning Speed Max. RPM	Resistance after run-in lb.ft. (Nm)	Lubrication Oil oz (ml)	Shipping Weight lb. (kg)
400	300 (408)	2,900	.20 (.27)	2 (59.1)	7 (3.2)
500	1,175 (1598)	2,650	.45 (.61)	3.5 (103.5)	12.5 (5.7)
600	2,250 (3060)	2,300	.90 (1.22)	6 (177.4)	20 (9)
700	5,000 (6800)	2,000	2.13 (2.89)	10 (295.7)	47 (21)
750	7,000 (9520)	1,800	3.75 (5.08)	20 (591.4)	88 (40)
800	13,000 (17,680)	1,400	5.25 (7.12)	25 (739.3)	112 (51)
900	18,000 (24,480)	1,300	6.25 (8.47)	30 (887.1)	170 (77)
1027	27,000 (36,720)	1,050	10.00 (13.56)	40 (1183.4)	315 (143)

#### Notes:

Check key and shaft stress before making final clutch selection since this may determine the maximum allowable drive torque capacity. Specify direction of rotation when ordering.

HSB-400 to 700 clutch assemblies are FSO clutches plus an HSB oil reservoir kit.

HSB-750 to 1027 clutch assemblies are FS clutches plus an HSB oil reservoir kit.

The reservoir kits are boxed separately.

Always consult the Installation and Maintenance Bulletin 2214, P-222-7 for the special seal modifications required to the FSO clutch when being used with the HSB oil reservoir kit, before attaching the reservoir.

### Typical Mounting Arrangement

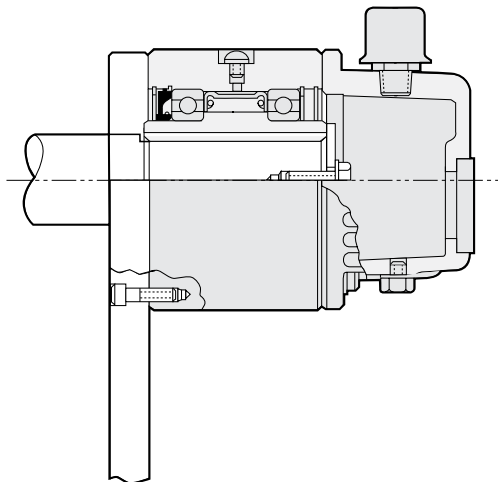

The Model HSB clutch with optional FSO Torque Arm, see Accessories, must be axially restrained on the shaft. The above typical drawing shows a customer supplied retaining plate and bolt and a stepped shaft, providing this restraint. All fasteners are recommended to be grade 8 bolts.

# Backstopping Clutches

## HSB (High Speed Backstops)

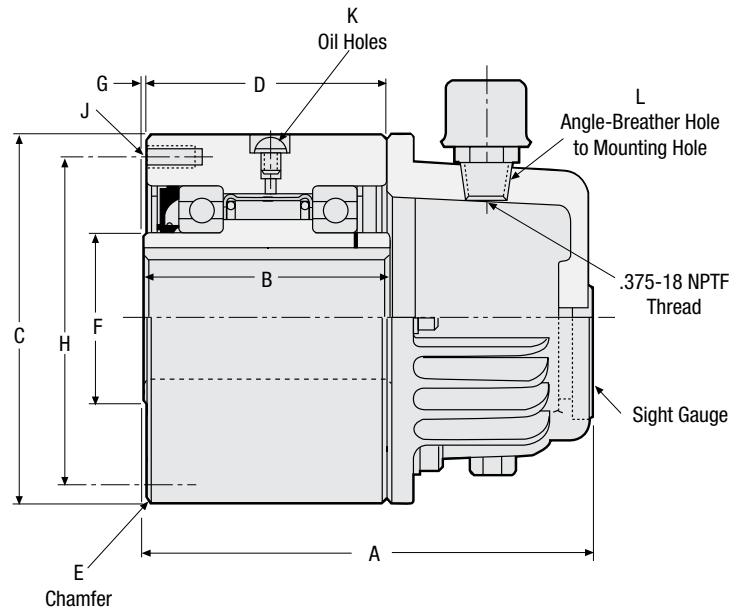

### Dimensions inches (mm)

Size	A	B	C	D	E	F	G	H	J			K	L*
									Number	Thread	Depth		
400	4.78 (121.44)	2.75 (69.85)	3.500/3.498 (88.90/88.85)	2.69 (68.25)	.06 x 45° (1.57 x 45°)	1.19 (29.97)	.03 (.78)	2.88 (73.02)	4 @ 90°	.312-24	.50 (12.70)	.250-28	45°
500	6.50 (165.10)	3.50 (88.90)	4.250/4.248 (107.95/107.90)	3.38 (85.72)	.06 x 45° (1.57 x 45°)	1.19 (30.15)	.06 (1.57)	3.63 (92.07)	4 @ 90°	.312-24	.63 (15.87)	.250-28	45°
600	6.75 (171.45)	3.75 (95.25)	5.375/5.373 (136.52/136.47)	3.63 (92.07)	.06 x 45° (1.57 x 45°)	1.75 (44.45)	.06 (1.57)	4.75 (120.65)	6 @ 60°	.312-24	.63 (15.87)	.250-28	30°
700	9.00 (228.60)	5.00 (127.00)	7.125/7.123 (180.97/180.92)	4.88 (123.82)	.06 x 45° (1.57 x 45°)	3.56 (90.42)	.06 (1.57)	6.25 (158.75)	8**	.375-24	.75 (19.05)	.250-28	0° or 30°
750	11.00 (279.40)	6.00 (152.40)	8.750/8.748 (222.25/222.20)	5.88 (149.22)	.06 x 45° (1.57 x 45°)	4.25 (107.95)	.06 (1.57)	7.00 (177.80)	8**	.500-20	1.00 (25.40)	.500-20	0° or 30°
800	11.50 (292.10)	6.00 (152.40)	10.000/9.998 (254.00/253.95)	5.88 (149.22)	.06 x 45° (1.57 x 45°)	5.50 (139.70)	.06 (1.57)	8.94 (227.00)	8 @ 45°	.500-20	1.00 (25.40)	.500-20	0° or 45°
900	12.25 (311.15)	6.38 (161.92)	12.000/11.997 (304.80/304.72)	6.25 (158.75)	.06 x 45° (1.57 x 45°)	6.38 (161.92)	.06 (1.57)	9.75 (247.65)	10 @ 36°	.625-18	1.25 (31.75)	.500-20	0° or 18°
1027	12.68 (322.07)	6.63 (168.27)	15.000/14.997 (381.00/380.92)	6.50 (165.10)	.13 x 45° (3.17 x 45°)	9.00 (228.60)	.06 (1.57)	11.75 (298.45)	12 @ 30°	.625-18	1.00 (25.40)	.500-20	15°

\* Angle-breather hole to mounting hole.

\*\* Six holes equally spaced at 60° plus two extra holes at 180°. Six hardened mounting screws are adequate for torque loads up to 3,000 lb.ft. (4068 Nm) for model 700, or 5,100 lb.ft. (6916 Nm) for model 750; use eight hardened mounting screws for torque loads above these values.

# Backstopping Clutches

HSB

## Bore sizes and keyseats\*\*\*† inches (mm)

Size	Bore Size	Keyseat	Bore Range	
			Min.	Max.
400	.500 (12.70)	1/8 x 1/16 (3.17 x 1.57)	.437 (11.10)	.875 (22.22)
	.625 (15.87)	3/16 x 3/32 (4.75 x 2.36)		
	.750 (19.05)			
500	.875 (22.22)	3/16 x 1/16 (4.75 x 1.57)	.750 (19.05)	1.312 (33.32)
	1.000 (25.40)			
	1.125 (28.57)	1/4 x 1/8 (6.35 x 3.17)		
	1.250 (31.75)			
600	1.312 (33.32)	1/4 x 3/32 (6.35 x 2.36)	.937 (23.80)	2.250* (57.15)
	1.250 (31.75)	1/4 x 1/8 (6.35 x 3.17)		
	1.375 (34.92)			
	1.500 (38.10)	3/8 x 3/16 (9.52 x 4.75)		
	1.625 (41.27)			
	1.750 (44.45)			
700	2.000 (50.80)	3/8 x 1/8 (9.52 x 3.17)	1.875 (47.62)	3.250** (82.55)
	1.937 (49.20)			
	2.000 (50.80)	1/2 x 1/4 (12.70 x 6.35)		
	2.250 (57.15)			
	2.437 (61.90)	5/8 x 5/16 (15.87 x 7.92)		
	2.500 (63.50)			
	2.750 (69.85)	5/8 x 7/32 (15.87 x 5.59)		
2.937 (74.60)	5/8 x 1/8 (15.87 x 3.17)			

\* 1/2 x 1/8 keyway

\*\* 3/4 x 1/4 keyway

\*\*\* For finished dimensions of keys supplied with the clutch, contact Formsprag.

† For Bore Sizes/Shaft Tolerances, see page 128.

Size	Bore Size	Keyseat	Bore Range	
			Min.	Max.
750	2.437 (61.90)	5/8 x 5/16 (15.87 x 7.92)	2.250 (57.15)	3.437 (87.30)
	2.500 (63.50)			
	2.750 (69.85)			
	2.937 (74.60)			
800	3.000 (76.20)	3/4 x 3/8 (19.05 x 9.52)	2.625 (66.67)	4.437 (112.70)
	3.250 (82.55)			
	3.437 (87.30)			
900	3.437 (87.30)	1 x 1/2 (25.40 x 12.70)	3.625 (92.07)	5.437 (138.10)
	3.500 (88.90)			
	3.750 (95.25)			
	3.937 (100.00)			
	4.000 (101.60)			
	4.250 (107.95)			
1027	4.437 (112.70)	1 1/4 x 5/8 (31.75 x 15.87)	4.937 (125.40)	7.000 (177.80)
	4.437 (112.70)			
	4.500 (114.30)			
	4.750 (120.65)			
	4.937 (125.40)			
	5.000 (127.00)			
	5.250 (133.35)			
5.437 (138.10)				
1077	4.937 to 6.000 (125.40 to 152.40)	1 1/2 x 1/2 (38.10 x 12.70)	4.937 (125.40)	7.000 (177.80)
	6.250 to 6.500 (158.75 to 165.10)			
	6.750 to 7.000 (171.45 to 177.80)			

# Holdback Clutches

## LLH<sup>®</sup> (Long Life Holdbacks<sup>®</sup>)

### Backstopping Technology

Formsprag offers two technologies in backstopping designs, Sprag and Ramp & Roller. The sprag design is comprised of a full complement of accurately formed sprags filling the annular space. The ramp & roller design consists of precision-machined ramps on the inner race and bearing quality cylindrical rollers filling the annular space.

In backstopping or holdback applications, one race is always fixed to a stationary ground member. The function of the holdback clutch is to permit rotation of the mechanism connected to the inner race in one direction only, and to prevent rotation in the reverse direction at any time. Although the clutch normally overruns most of the time, it is referred to as a holdback or backstop in conveyors, gear reducers and similar equipment, because its function is to prevent reverse rotation.

LLH holdback clutches are ready to install. They are equipped with a one-piece, quickly detachable torque arm (simply remove two pins), and grease labyrinth protected oil seals that positively prevent airborne contaminants from reaching internal seals and parts. Oil lubricated, the clutch assembly also includes an oil sight gauge with filter breather, for ease in checking lubricant level. These clutches are designed to be mounted on a through shaft, with the inner race driven by a key. Standard keys are supplied by Formsprag with all holdbacks at no additional charge.

### Sprag Design

(Models LLH-700S through LLH-5000S)

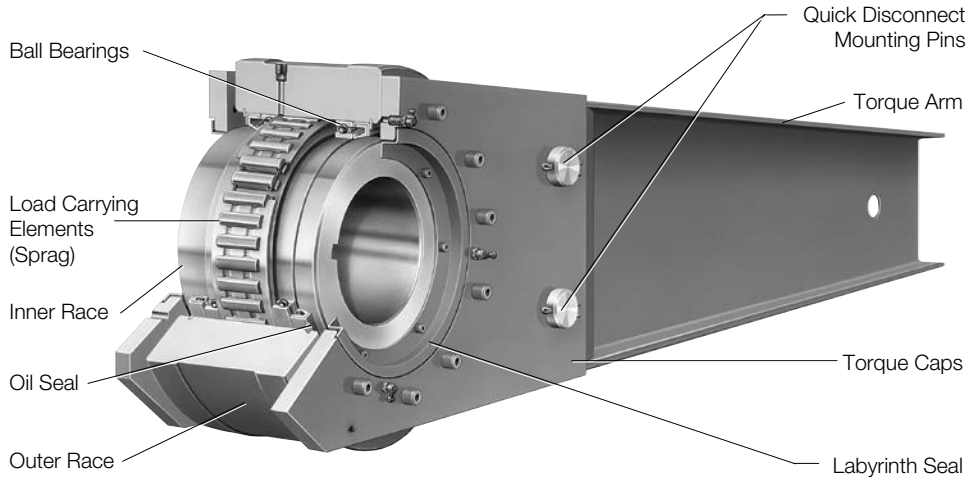

### Ramp and Roller Design

(Models LLH-1250R through LLH-5500R)

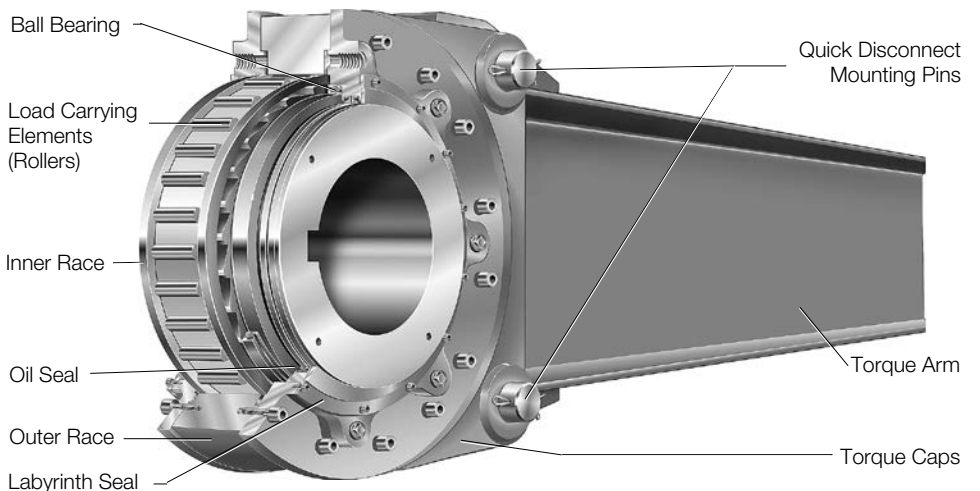

### Typical Holdback Specifications

- LLH holdback units are designed for installation on primary drive line shafting with typical dimensional tolerances and run-outs. Some applications dictate installation in locations not in the primary drive line, i.e. in locations where tolerances and run-outs exceed "typical" values. In these situations, some basic measurements are required to determine the suitability of the proposed mounting location. Holdback lubrication sealing and overall product life can be adversely affected by excessive shaft run-out or lack of straightness.

Prior to installation in a location outside the primary drive line, shaft run-out should be measured in at least two locations in the holdback mounting area. Measured values should not exceed those in the table below:

<u>Max Overrunning Speed, RPM</u>	<u>Maximum TIR, inches</u>
Thru 100	0.010
Thru 150	0.006
Thru 250	0.004
Thru 400	0.002

Across the holdback mounting area, the shaft should be straight within 0.003 inches per foot of length.

These requirements are based on maintaining acceptable axial and radial vibration levels on the holdback. Installations that exceed these limits can result in leakage of lubricant from the holdback, excessive seal wear, and premature failure of bearings and/or Sprags.

- Holdbacks installed on elevators and inclined conveyors must have adequate torque capacity to prevent runback, and must comply with the holdback manufacturer's recommended practice in the selection and application of a safe size.
- The sprags within the holdback must be positioned and individually energized within a suitable retainer. Sprags must act independent of the retainer and independent of the action of any other sprag.
- The sprags and the bearings within the holdback must be lubricated with lubricant suitable for the applicable extremes of ambient temperatures. The lubrication system must incorporate a transparent area suitable for visual checking of the oil level at approximately the level of the centerline of the shaft, suitable fitting

### Specifications

Size	Torque Capacity lb.ft. (Nm)	Maximum Overrunning Speed RPM	Resistance after run-in lb.ft. (Nm)	Bore Range Available		Shipping Weight lb. (kg)
				Min. in. (mm)	Max. in. (mm)	
700	5,000 (6800)	400	2.63 (3.57)	1.875 (47.63)	2.937 (74.60)	160 (72)
750	7,000 (9520)	380	3.75 (5.09)	2.250 (57.15)	3.437 (87.30)	215 (97)
800	13,000 (17680)	300	5.25 (7.12)	2.625 (66.68)	4.437 (112.70)	325 (147)
900	18,000 (24480)	250	6.25 (8.48)	3.625 (92.08)	5.437 (138.10)	570 (258)
1027	27,000 (36720)	200	10 (13.56)	4.937 (125.40)	7.000 (177.80)	750 (340)
1051	45,000 (61200)	200	12 (16.27)	4.937 (125.40)	7.000 (177.80)	800 (363)
1250	65,000 (88400)	170	15 (20.34)	6.750 (171.45)	9.000 (228.60)	1,400 (633)
1300	90,000 (122400)	140	28 (37.97)	7.937 (201.60)	10.000 (254.00)	1,700 (770)
1375	135,000 (183600)	130	39 (52.87)	8.937 (227.00)	11.000 (279.40)	2,200 (995)
2000	200,000 (272000)	100	80 (108.48)	10.937 (277.80)	13.250 (336.55)	3,200 (1452)
2400	265,000 (360400)	85	100 (135.60)	13.000 (330.20)	15.500 (393.70)	4,200 (1905)
3500	375,000 (510000)	80	120 (162.72)	13.437 (341.30)	20.000 (508.00)	5,850 (2653)
5000	700,000 (952000)	75	125 (169.50)	13.437 (341.30)	20.000 (508.00)	5,930 (2690)

for draining oil from the holdback, means for filling the holdback with oil, and a breather to relieve pressure within the holdback. The breather must be equipped with a renewable filter arranged to prevent entry of foreign matter into the lubrication system. The breather and filter may be incorporated into the oil filling fitting. An oil seal must be installed externally of each bearing.

- For dusty or abrasive atmospheres the holdbacks must be equipped with a grease-filled labyrinth seal external to each oil seal.  
A sufficient number of grease fittings must be provided to insure complete filling and purging of the labyrinth.
- The holdback must be symmetrical to permit field installation for either direction of rotation without disassembly of the sealed holdback assembly.
- The holdback must be equipped with torque arm securely fastened to the outer race of the clutch. The outer end of the torque arm must be restrained by means that allow the

arm to float while preventing rotation of the outer race.

- The torque and speed capacity specified by the holdback manufacturer must be based upon adequate tests and engineering documentation. Since these units are used as safety devices, an adequate design safety factor must be used. The compressive stress used in the Hertz stress equations will not exceed 450,000 psi.
- Load carrying elements in the holdbacks will preferably be manufactured from steel forgings, extrusions or bar stock.
- To assure that proper heat treatment has been given to the holdback parts, relative to hardness, case depth and micro-structure, a certificate of quality attesting to proper metallurgical examination of the above mentioned items by the holdback manufacturer's laboratory will be provided to the purchaser.

# Holdback Clutches

## LLH

### Application Information

Formsprag Long Life Holdbacks are designed to “holdback” reverse torque. They are commonly used on inclined conveyors, bucket elevators, or pumps. Holdbacks have also been used on people moving systems, such as ski lifts and elevators. Specially designed nuclear holdbacks are currently installed on vertical shaft applications in several nuclear power plants with a required 40-year life.

**Torque Arm Mounting Positions** — The Holdback should be mounted in an orientation so that the weight of the torque arm will keep the torque arm in constant contact with the reacting surface

and structure. With standard oil sight gauges, the preferred torque arm mounting position is approximately horizontal or slightly off of vertical. For installations requiring torque arms oriented in some other position, consult Formsprag.

**Axial Retention Collars** — Formsprag recommends that holdbacks be axially restrained on the shaft. The preferred method of accomplishing this is with set collars (see page 122). Any type of axial restraint applied to the torque arm reaction end will result in uneven bearing loads that will greatly reduce the bearing B-10 life. Restraint keys are also available. See page 123.

### Typical Conveyor Holdback Arrangements

#### Single Head Pulley Drive

Locate the holdback on the opposite end of the head pulley drive shaft from the drive motor, speed reducer and coupling.

There are two rules for selecting holdbacks:

1. The holdback should always be mounted on the drive shaft.
2. The torque capacity of the holdback should be equal to or greater than the rated capacity of the drive motor.

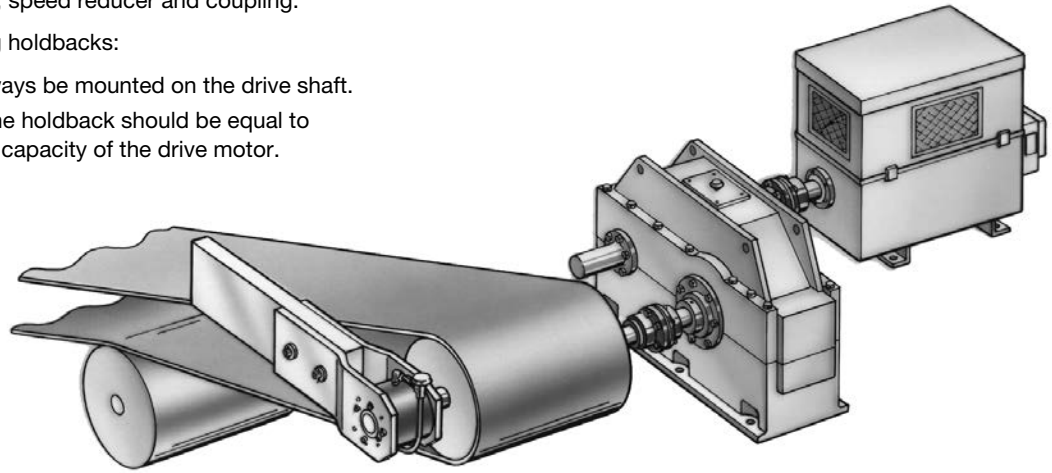
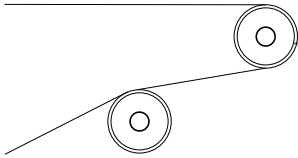

#### Single Drive Pulley Other Than Head Pulley

Locate the holdback on the drive pulley shaft, at the opposite end from the drive motor, speed reducer and coupling.

There are two rules for selecting holdbacks:

1. The holdback should always be mounted on the drive shaft.
2. The torque capacity of the holdback should be equal to or greater than the rated capacity of the drive motor.

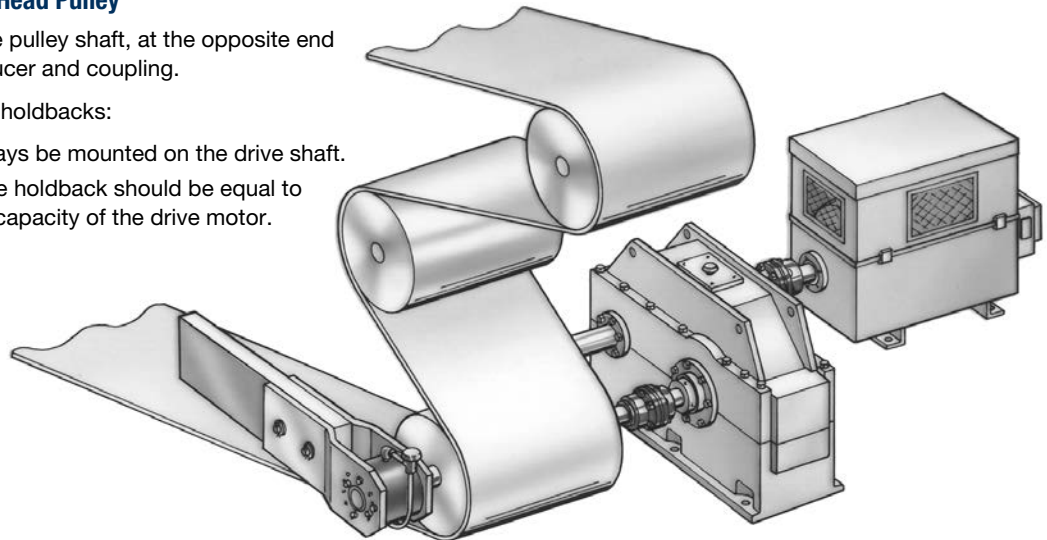
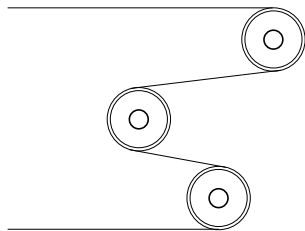



**Auxiliary Seals** — All Formsprag holdbacks are furnished with two grease labyrinth-type seals. These seals, when purged with fresh grease periodically in accordance with our maintenance instructions, will protect the clutch against dusty or abrasive environments.

**Operating Temperatures** — For temperatures above 200°F consult Formsprag.

**Standard Supplied Keys** — All holdbacks are furnished with a hardened (25 – 40Rc) key. Customers should check key and

shaft stress before making final clutch selection since this may determine the maximum allowable drive torque capacity. Do not drive or press-fit the key. It should be installed in the shaft keyway with a “push” fit.

**Extended Storage** — If holdbacks are kept out of operation for six months or more, they should be flushed out and relubricated prior to operation. If holdbacks are to be stored over an extended period of time, consult Formsprag for specific preservation and packaging instructions. See page 81 for extended storage.

## Single Pulley With Dual Drive

Contact Formsprag for selection information on other possible holdback mounting arrangements.

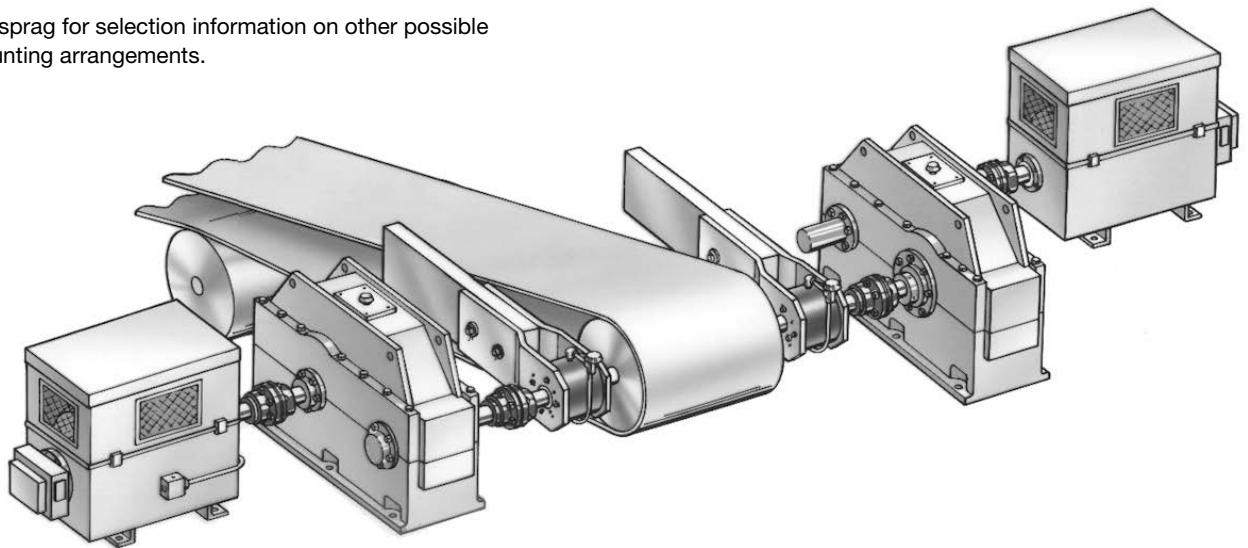

## Tandem Drive Pulleys

Contact Formsprag for selection information on other possible holdback mounting arrangements.

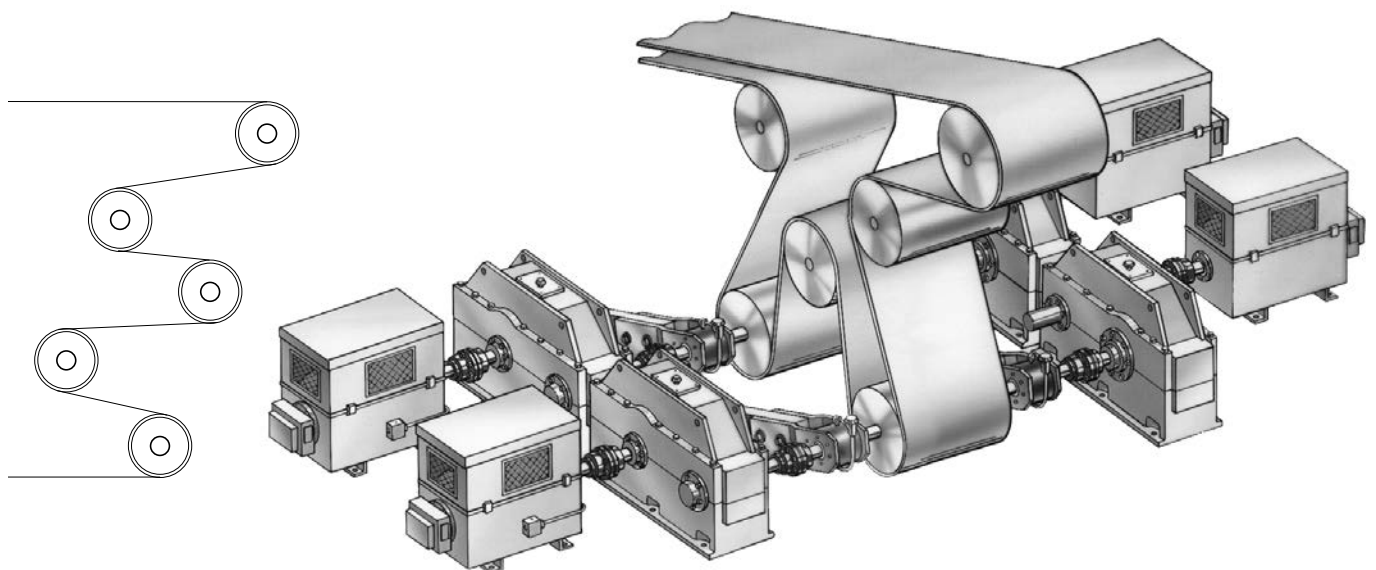

# Holdback Clutches

## LLH

Model sizes 700 through 900

### Horizontal Mounting

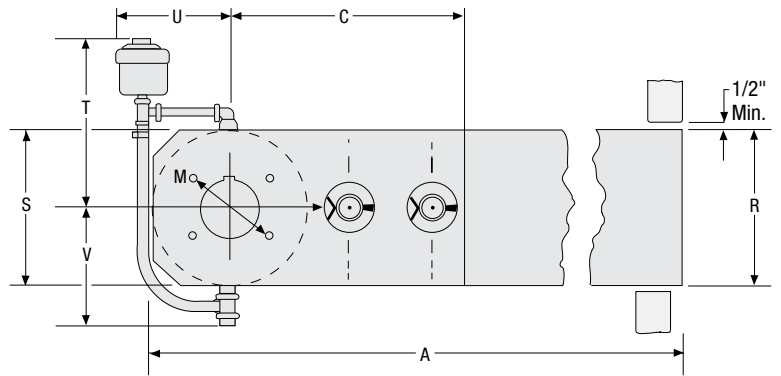
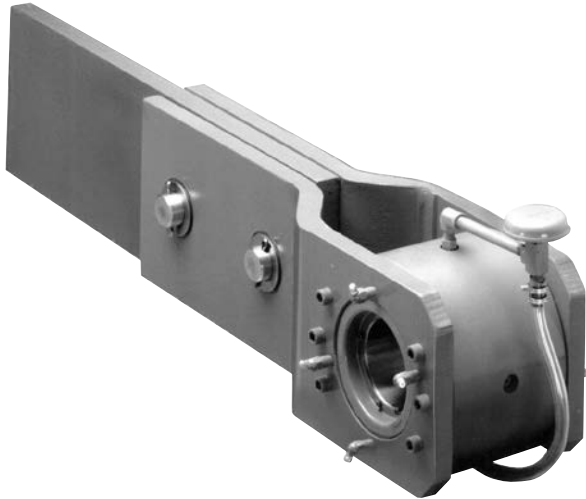

Sizes 700 through 800

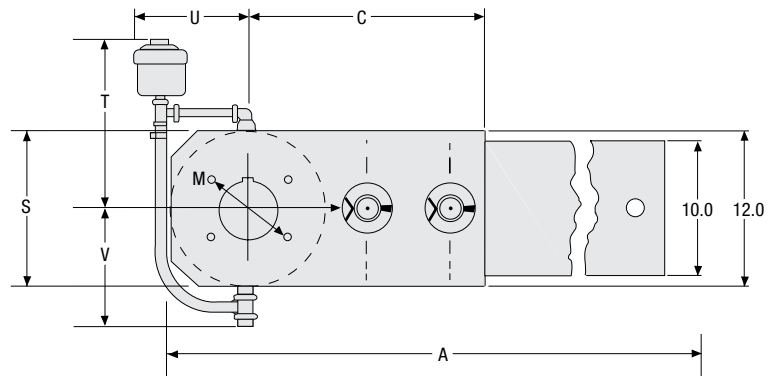

Size 900

### Dimensions inches (mm)

Size	A	B	C	F	G	H	J	L	M	N	P
700	33.63 (854.07)	30.00 (762.00)	18.00 (457.20)	8.25 (209.55)	7.13 (180.97)	6.38 (161.92)	5.00 (127.00)	3.63 (92.07)	5.31 (134.92)	3.88 (98.42)	2.50 (63.50)
750	36.38 (923.92)	32.00 (812.80)	20.38 (517.52)	9.25 (234.95)	8.38 (212.72)	7.38 (187.32)	6.00 (152.40)	4.63 (117.47)	5.81 (147.62)	3.88 (98.42)	2.50 (63.50)
800	37.00 (939.80)	32.00 (812.80)	22.13 (561.97)	9.50 (241.30)	8.63 (219.07)	7.63 (193.67)	6.00 (152.40)	5.44 (138.10)	7.31 (185.72)	4.19 (106.35)	2.75 (69.85)
900	50.00 (1270.00)	44.00 (1117.60)	22.75 (577.85)	9.75 (247.65)	9.25 (234.95)	8.00 (203.20)	6.38 (161.92)	6.44 (163.50)	8.56 (217.47)	4.69 (119.05)	3.25 (82.55)

\* Model 700 through 900, pins are on centerline of torque arm.

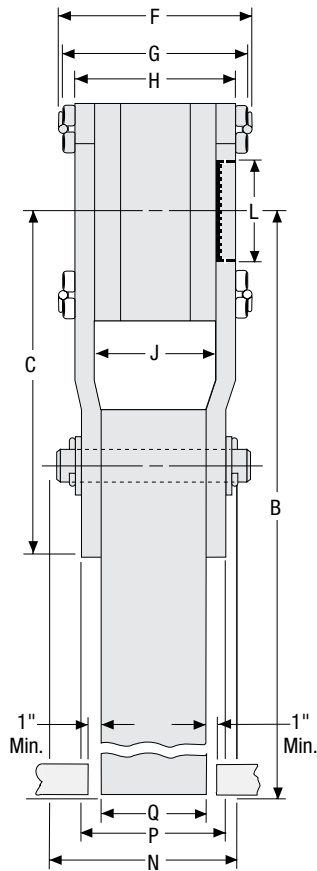
**Sizes 700 through 900**
**Dimensions inches (mm)**

Size	Q	R	S	T	U	V
700	1.00 (25.40)	7.00 (177.80)	7.13 (180.97)	6.00 (152.40)	6.00 (152.40)	5.00 (127.00)
750	1.00 (25.40)	8.00 (203.20)	8.00 (203.20)	11.50 (292.10)	7.25 (184.15)	7.25 (184.15)
800	1.00 (25.40)	10.00 (254.00)	10.00 (254.00)	12.50 (317.50)	8.00 (203.20)	7.75 (196.85)
900	1.50 (38.10)	10.00 (254.00)	12.00 (304.80)	13.50 (342.90)	9.25 (234.95)	8.75 (222.25)

**Bore sizes and keyseats\*† inches (mm)**

Size	Bore Size	Keyseat	Bore Range	
			Min.	Max.
700	1.937 (49.20)	1/2 x 1/4 (12.70 x 6.35)	1.875 (47.62)	3.250 (74.60)
	2.000 (50.80)			
	2.250 (57.15)			
	2.437 (61.90)	5/8 x 5/16 (15.87 x 7.93)		
	2.500 (63.50)			
	2.750 (69.85)	5/8 x 7/32 (15.87 x 5.56)		
2.937 (74.60)	5/8 x 1/8 (15.87 x 3.18)			
750	2.437 (61.90)	5/8 x 5/16 (15.87 x 7.93)	2.250 (57.15)	3.437 (87.30)
	2.500 (63.50)			
	2.750 (69.85)			
	2.937 (74.60)	3/4 x 3/8 (19.05 x 9.52)		
	3.000 (76.20)			
	3.250 (82.55)	3/4 x 1/4 (19.05 x 6.35)		
	3.437 (87.30)	3/4 x 3/16 (19.05 x 4.75)		
	800	2.937 (74.60)		
3.000 (76.20)				
3.250 (82.55)				
3.437 (87.30)		7/8 x 7/16 (22.22 x 11.10)		
3.500 (88.90)				
3.750 (95.25)				
3.937 (100.00)		1 x 1/2 (25.40 x 12.70)		
4.000 (101.60)				
4.250 (107.95)				
4.437 (112.70)				
900	3.937 (100.00)	1 x 1/2 (25.40 x 12.70)	3.625 (92.07)	5.437 (138.10)
	4.000 (101.60)			
	4.250 (107.95)			
	4.437 (112.70)			
	4.500 (114.30)			
	4.750 (120.65)			
	4.937 (125.40)	1 x 3/8 (25.40 x 9.52)		
	5.000 (127.00)			
	5.250 (133.35)	1 x 1/4 (25.40 x 6.35)		
	5.437 (138.10)			

\* For finished dimensions of keys supplied with the clutch, contact Formspag.

† For Bore Sizes/Shaft Tolerances, see page 82.

# Holdback Clutches

**LLH**

Model Sizes 1027 Through 5000

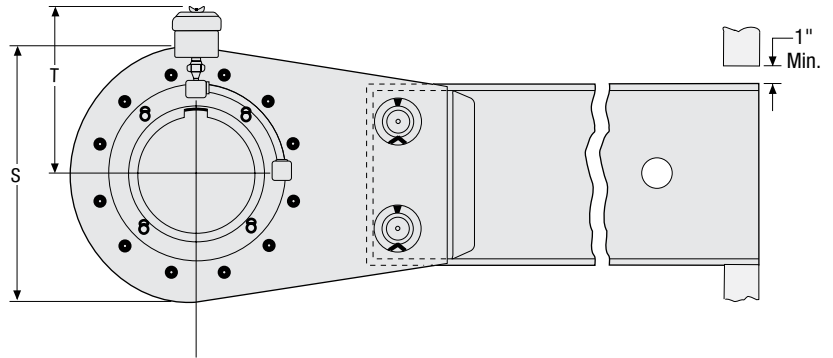
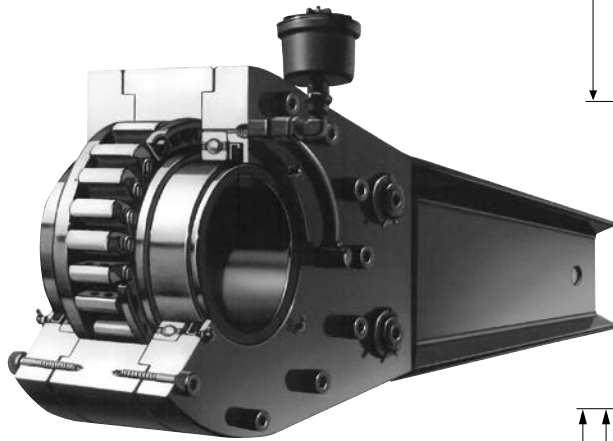

**Horizontal Mounting**

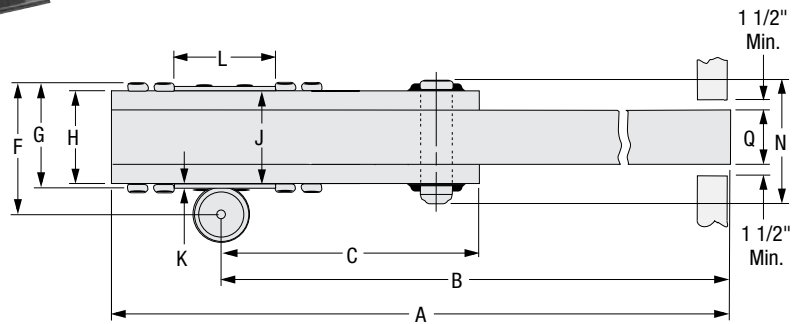

**Dimensions** inches (mm)

Size	A	B	C	F	G	H	J	K	L	M	N
1027	68.63 (1743.55)	61.88 (1571.62)	18.00 (457.20)	9.63 (244.47)	9.50 (241.30)	8.25 (209.55)	6.63 (168.27)	—	8.88 (225.42)	10.75 (273.05)	10.00 (254.00)
1051	68.63 (1743.07)	61.13 (1552.57)	18.00 (457.20)	14.25 (361.95)	10.75 (273.05)	9.50 (241.30)	9.63 (244.47)	0.06 (1.57)	8.63 (219.07)	9.63 (244.47)	11.88 (301.62)
1250	76.00 (1930.40)	66.00 (1676.40)	20.25 (514.36)	14.97 (380.24)	11.57 (293.88)	9.80 (248.92)	10.25 (260.35)	.23 (5.84)	10.56 (268.22)	12.00 (304.80)	12.00 (304.80)
1300	77.75 (1974.85)	67.00 (1701.80)	21.81 (553.97)	15.10 (383.54)	11.87 (300.23)	9.80 (248.92)	10.25 (260.35)	.23 (5.84)	11.72 (297.69)	13.00 (330.20)	12.00 (304.80)
1375	82.25 (2089.15)	70.00 (1778.00)	24.50 (622.30)	15.22 (386.59)	12.07 (306.58)	9.80 (248.92)	11.00 (279.40)	.61 (15.494)	13.56 (344.42)	15.00 (381.00)	12.00 (304.80)
2000	97.00 (2463.80)	82.00 (2082.80)	29.44 (747.70)	15.38 (390.52)	12.38 (314.32)	10.38 (263.52)	10.62 (269.8)	0.13 (3.17)	17.56 (446.07)	19.25 (488.95)	13.00 (330.20)
2400	100.50 (2552.70)	82.50 (2095.50)	34.19 (868.35)	15.38 (390.52)	12.38 (314.32)	10.63 (269.87)	10.88 (276.22)	0.13 (3.17)	19.56 (496.87)	21.25 (539.75)	13.25 (336.55)
3500	101.50 (2578.10)	82.50 (2095.50)	34.12 (866.65)	20.16 (512.06)	17.00 (431.80)	14.75 (374.65)	18.00 (457.20)	1.03 (26.16)	22.46 (570.48)	26.00 (660.40)	16.75 (425.45)
5000	101.50 (2578.10)	82.50 (2095.50)	34.12 (866.65)	24.66 (626.36)	21.50 (546.10)	19.25 (488.95)	22.81 (579.37)	1.03 (26.16)	22.46 (570.48)	26.00 (660.40)	21.25 (539.75)

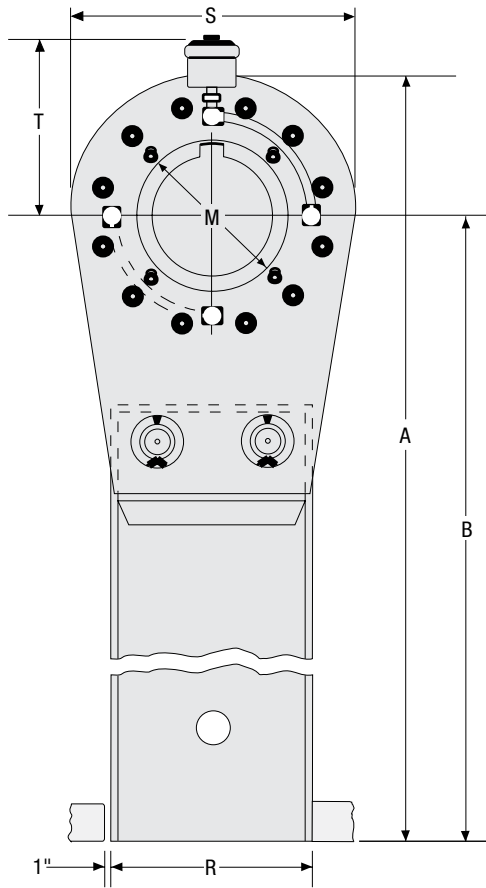

### Vertical Mounting

(Must be mounted at least 10° off of vertical)

### Dimensions inches (mm)

Size	P*	Q	R	S	T
1027	8.25 (209.55)	5.25 (133.35)	12.00 (304.80)	15.00 (381.00)	14.50 (368.30)
1051	9.50 (241.30)	5.25 (133.35)	12.00 (304.80)	15.00 (381.00)	12.00 (304.80)
1250	—	5.50 (139.70)	15.00 (381.00)	20.00 (508.00)	13.17 (334.52)
1300	—	6.25 (158.75)	18.00 (457.20)	21.50 (546.10)	13.42 (340.87)
1375	—	6.25 (158.75)	18.00 (457.20)	24.50 (622.30)	14.55 (369.57)
2000	—	7.13 (180.97)	24.00 (609.60)	30.00 (762.00)	17.25 (438.15)
2400	—	7.88 (200.02)	24.00 (609.60)	36.00 (914.40)	18.75 (476.25)
3500	—	8.00 (203.20)	24.00 (609.60)	38.00 (965.20)	20.17 (512.32)
5000	—	8.00 (203.20)	24.00 (609.60)	38.00 (965.20)	20.17 (512.32)

\* Width over torque cap, see page 73.

### Bore sizes and keyseats\*\*† inches (mm)

Size	Bore Size	Keyseat	Bore Range	
			Min.	Max.
1027	4.937 (125.40) to 6.000 (152.40)	1 1/4 x 5/8 (31.75 x 15.87)	4.937 (125.40)	7.000 (177.80)
	6.250 (158.75) to 6.500 (165.10)	1 1/2 x 1/2 (38.10 x 12.70)		
	6.750 (171.45) to 7.000 (177.80)	1 1/2 x 7/16 (38.10 x 11.10)		
1051	5.000 (127.00) to 6.000 (152.40)	1 1/4 x 5/8 (31.75 x 15.88)	4.937 (125.40)	7.000 (177.80)
	6.250 (158.75) to 6.625 (162.28)	1 1/2 x 5/8 (38.10 x 15.88)		
	6.750 (171.45) to 6.875 (174.63)	1 1/2 x 1/2 (38.10 x 12.70)		
	7.000 (177.80)	1 1/2 x 7/16 (38.10 x 11.11)		
1250	7.50 (190.50) to 7.937 (201.60)	1 3/4 x 7/8 (44.45 x 22.35)	6.750 (171.45)	9.000 (228.60)
	8.000 (203.20) to 8.250 (209.55)	1 3/4 x 5/8 (44.45 x 16.00)		
	8.312 (211.12) to 9.000 (228.60)	1 1/2 x 1/2 (38.10 x 12.70)		
	9.000 (228.60)	1 1/2 x 7/8 (38.10 x 22.35)		
1300	8.000 (203.20) to 9.000 (228.60)	1 3/4 x 7/8 (44.45 x 22.35)	7.937 (201.60)	10.000 (254.00)
	9.063 (230.20) to 10.000 (254.00)	1 1/2 x 1/2 (38.10 x 12.70)		
	10.000 (254.00)	1 1/2 x 7/8 (38.10 x 22.35)		
1375	9.000 (228.60) to 10.250 (260.35)	1 3/4 x 7/8 (44.45 x 22.35)	8.937 (227.00)	11.000 (279.40)
	10.312 (261.93) to 11.00 (279.40)	2 x 3/4 (50.80 x 19.05)		
	11.00 (279.40)	2 x 3/4 (50.80 x 19.05)		
2000	10.937 (277.80) to 12.000 (304.80)	2 1/2 x 1 1/4 (63.50 x 31.75)	10.937 (277.80)	13.250 (336.55)
	12.063 (306.40) to 13.250 (336.55)	2 1/2 x 1 (63.50 x 25.40)		
	13.000 (330.20) to 15.000 (381.00)	2 1/2 x 1 1/4 (63.50 x 31.75)		
2400	15.063 (382.60) to 15.500 (393.70)	2 1/2 x 1 (63.50 x 25.40)	13.000 (330.20)	15.500 (393.70)
	15.500 (393.70)	2 1/2 x 1 (63.50 x 25.40)		
3500	13.437 (341.30) to 13.750 (349.25)	2 1/2 x 1 1/4 (63.50 x 31.75)	13.437 (341.30)	20.00 (508.00)
	14.000 (355.60) to 18.000 (457.20)	3 x 1 1/2 (76.20 x 38.10)		
	20.000 (508.00)	3 x 1 1/4 (76.20 x 31.75)		
	13.437 (341.30) to 13.750 (349.25)	2 1/2 x 1 1/4 (63.50 x 31.75)		
5000	14.000 (355.60) to 18.000 (457.20)	3 x 1 1/2 (76.20 x 38.10)	13.437 (341.30)	20.00 (508.00)
	18.000 (457.20) to 20.000 (508.00)	3 x 1 1/4 (76.20 x 31.75)		
	20.000 (508.00)	3 x 1 1/4 (76.20 x 31.75)		
	20.000 (508.00)	3 x 1 1/4 (76.20 x 31.75)		

\*\* For finished dimensions of keys supplied with the clutch, contact Formspag.

† For Bore Sizes/Shaft Tolerances, see page 82.

# Holdback Clutches

## LLH

Model Sizes 1250R Through 5500R

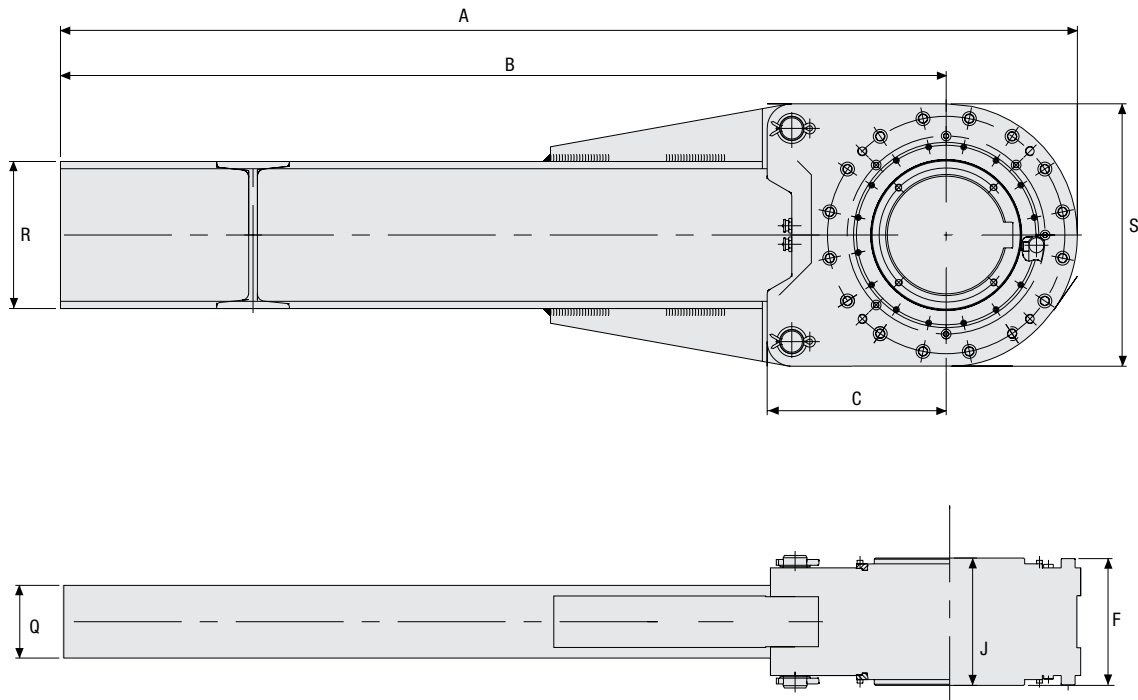

### Dimensions inches (mm)

Model No.	Torque Capacity	Maximum Overrunning Speed	A	B	C	F	J	Shipping Weight
1250R	63,000 (85909)	120	87.44 (2221)	77.95 (1980)	12.25 (311)	9.3 (236)	9.3 (236)	830 (381)
1300R	90,000 (122040)	105	91.89 (2334)	81.89 (2080)	14.25 (362)	10.5 (267)	10.5 (267)	1,130 (520)
1375R	135,000 (183060)	90	99.61 (2530)	87.99 (2235)	16.06 (408)	11.75 (298)	11.75 (298)	1,500 (690)
2000R	180,000 (244407)	80	107.72 (2736)	94.09 (2390)	16.54 (420)	12.6 (320)	12.6 (320)	2,100 (966)
2400R	240,000 (325,396)	70	115.16 (2925)	100.00 (2540)	18.0 (457)	16.0 (406)	16.0 (406)	2,700 (1242)
3500R	375,000 (508432)	60	138.89 (3528)	120.00 (3048)	23.0 (584)	18.75 (476)	18.7 (476)	6,000 (2760)
5000R	540,000 (732142)	60	166 (4216)	144 (3658)	26.50 (673)	22.5 (572)	22.5 (572)	9,000 (4140)
5500R	720,000 (976271)	60	166 (4216)	144 (3658)	26.50 (673)	23.5 (597)	23.5 (597)	10,000 (4545)

\* Torque arm I-beam. S-type section dimensions may vary according to the American Iron and Steel Institute or DIN standards.

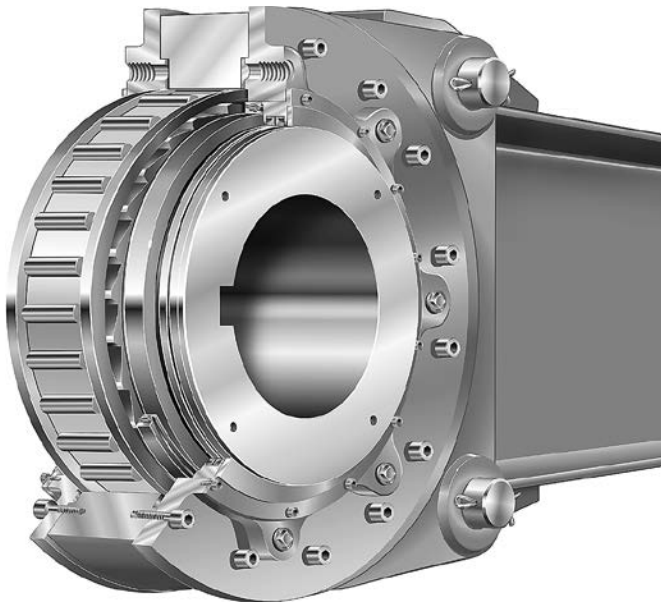

### Dimensions inches (mm)

Model No.	Q*	R*	S
1250R	5.00 (127)	10.00 (254)	19.6 (489)
1300R	5.51 (140)	12.01 (305)	23.0 (584)
1375R	5.62 (143)	15.00 (381)	25.7 (653)
2000R	6.26 (159)	18.00 (457)	30.3 (770)
2400R	6.38 (162)	20.00 (508)	34.5 (876)
3500R	8.00 (203)	24.20 (615)	41.0 (1041)
5000R	10.12 (257)	27.20 (691)	47.0 (1194)
5500R	10.12 (257)	27.20 (691)	47.0 (1194)

### Bore sizes and keyseats\*\*† inches (mm)

Model No.	Bore Size	Keyseat	Bore Range	
			Min.	Max.
1250R	6.000 (152.00) to 6.500 (165.10)	1.500 x .75 (38.10 x 19.05)	5.25 (133.35)	8.000 (203.2)
	6.563 (166.70) to 7.500 (190.50)	1.750 x .75 (44.45 x 15.88)		
	7.563 (192.10) to 8.250 (209.55)	2.000 x .75 (50.80 x 19.05)		
1300R	6.500 (165.10)	1.500 x .75 (38.10 x 12.70)	5.75 (146.05)	9.000 (230.00)
	6.563 (166.70) to 7.500 (190.50)	1.750 x .75 (44.45 x 19.05)		
	7.563 (192.10) to 8.750 (222.25)	2.000 x .75 (50.80 x 19.05)		
	7.750 (196.85) to 9.000 (228.60)	2.000 x .75 (50.80 x 19.05)		
1375R	9.063 (230.20) to 10.250 (260.35)	2.500 x .88 (63.50 x 22.23)	6.75 (171.45)	10.500 (270.00)
	9.000 (228.60)	2.000 x .75 (50.80 x 19.05)		
	11.000 (279.40)	2.500 x .88 (63.50 x 22.23)		
2000R	11.063 (281.00) to 12.000 (304.80)	3.000 x 1.00 (76.20 x 25.40)	7.25 (184.15)	11.75 (298.45)
	11.000 (279.40)	2.500 x .88 (63.50 x 22.23)		
	13.000 (330.20)	3.000 x 1.00 (76.20 x 25.40)		
2400R	13.063 (331.80) to 13.750 (249.25)	3.500 x 1.25 (88.90 x 31.75)	8.25 (209.55)	14.000 (360.00)
	13.000 (330.20)	3.000 x 1.00 (76.20 x 25.40)		
	13.063 (281.00) to 13.000 (330.20)	3.000 x 1.00 (76.20 x 25.40)		
	13.063 (331.80) to 13.750 (249.25)	3.500 x 1.25 (88.90 x 31.75)		
3500R	15.000 (381.00)	3.500 x 1.25 (88.90 x 31.75)	10.25 (260.35)	18.00 (457.20)
	13.063 (331.80) to 15.000 (381.00)	3.500 x 1.25 (88.90 x 31.75)		
	15.063 (382.60) to 17.000 (431.80)	4.000 x 1.50 (101.60 x 38.10)		
5000R and 5500R	13.000 (330.20)	3.000 x 1.00 (76.20 x 25.40)	15.25 (387.35)	21.00 (533.40)
	13.063 (331.80) to 15.000 (381.00)	3.500 x 1.25 (88.90 x 31.75)		
	15.063 (382.60) to 18.000 (457.20)	4.000 x 1.50 (101.60 x 38.10)		
	18.000 (457.20)	4.000 x 1.50 (101.60 x 38.10)		
	18.063 (458.80) to 22.000 (558.80)	5.000 x 1.75 (127.00 x 44.45)		
	22.000 (558.80)	5.000 x 1.75 (127.00 x 44.45)		
	22.063 (560.40) to 21.000 (533.4)	6.000 x 4.00 (152.40 x 101.60)		
	21.000 (533.4)	6.000 x 4.00 (152.40 x 101.60)		

\*\* For finished dimensions of keys supplied with the clutch, contact Formsprag.

† For Bore Sizes/Shaft Tolerances, see page 82.

# Holdback Clutches

## LLH

### Selection Procedure

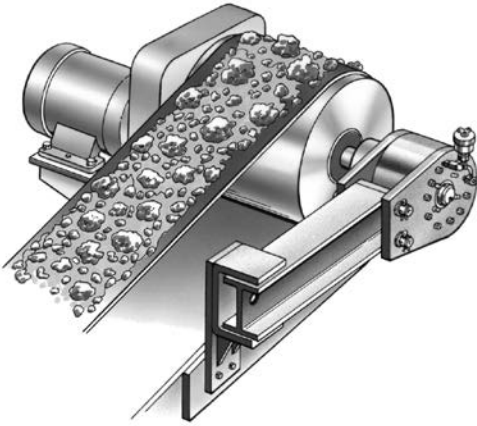

### Conveyors

The CEMA Formula calculates the motor breakdown or stall torque which could be imposed on the backstop if the conveyor is jammed or frozen, or when the conveyor is overloaded. In this condition the motor will produce stall torque which is significantly higher than the motor nameplate rating. This will cause the belt to stretch; and when the motor stalls, the stall torque produced by the motor will be imposed on the backstop. This torque will be increased if there is a load on the belt. Therefore, the maximum loading on a backstop occurs in the rare case of a moving belt being gradually overloaded until the motor reaches stall or breakdown torque. The torque on the backstop will be the motor torque from the stretched belt plus the torque from the load moving in the reverse direction due to the force of gravity.

To select a holdback based on motor breakdown torque, calculate motor torque using the following formula:

$$T_{\text{motor}} \text{ (lb.ft.)} = \frac{\text{(S.F.) (Motor Nameplate HP) (5,250)}}{\text{(Headshaft RPM)}}$$

The clutch may be selected on the basis of installed nameplate horsepower without using a service factor (S.F.), provided the motor breakdown torque does not exceed 175 percent of the nameplate rating; a minimum service factor based upon the ratio of motor breakdown torque to 175 percent of nameplate torque is required in order to preclude serious damage to the installation or to the holdback.

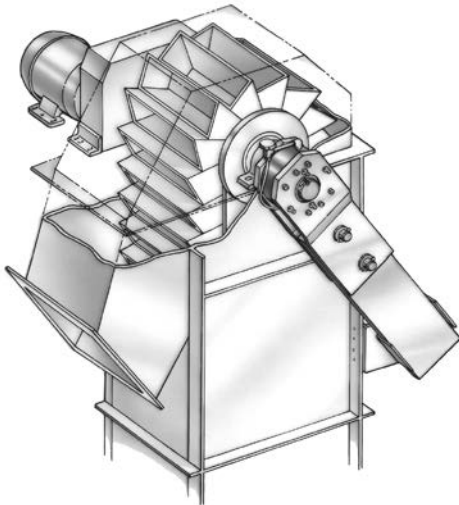

### Bucket Elevators

When selecting and sizing long life holdbacks application on bucket elevators, friction may or may not be considered because it is usually only a small fraction of the lift HP required. Similarly, motor breakdown HP is usually not considered if traction wheel drives are used because the elevator will usually slip before the breakdown HP is reached. For these reasons, the recommended design torque is based on lift HP alone.

$$T_B \text{ (lb.ft.)} = \frac{\text{(S.F.) (Lift HP) (5,250)}}{\text{(Headshaft RPM)}}$$

A minimum service factor (S.F.) of 2.0 is recommended. If additional assistance is needed, consult Formsprag Application Engineering.



### OSHA Cover Kit

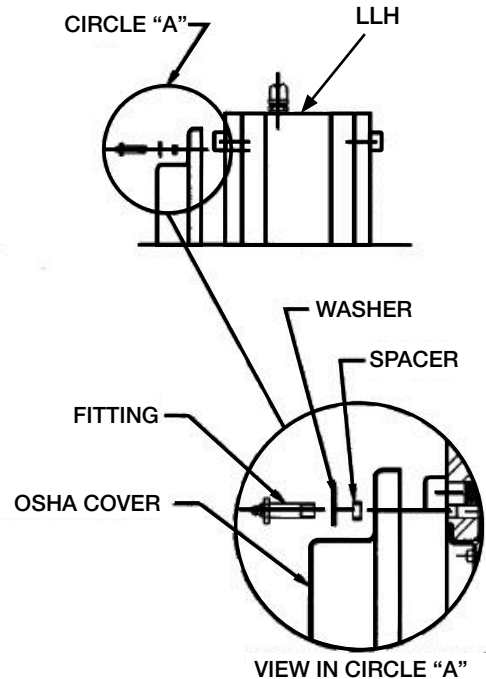

OSHA end cover kits for shaft end mounted LLH units are available from Formsprag. These cover kits provide not only the stationary cover enclosure required by OSHA, but additional protection for the LLH from abrasive environments as well.

**Note:** OSHA requires that clutches with projecting parts (and operating seven (7) feet or less above the floor) must be enclosed by a stationary guard (see below). Also, shaft couplings with bolts, nuts and set screws must be covered with safety sleeves unless they are countersunk or do not extend beyond the flange of the coupling (see below).

(k) *Guarding of clutches, cutoff couplings, and clutch pulleys*—(1) *Guards.* Clutch cutoff couplings, or clutch pulleys having projecting parts, where such clutches are located seven (7) feet or less above the floor or less above the floor or working platform, shall be enclosed by a stationary guard constructed in accordance with this section. A “U” type guard is permissible.

Size	End Cover Part No.	Dimension “A” Inches
LLH-700	CL-7891	2.00
LLH-750	CL-7892	2.00
LLH-800	CL-7893	2.00
LLH-900	CL-7894	2.00
LLH-1027	CL-7895	2.50
LLH-1051	CL-7896	2.50
LLH-1250	CL-7897	2.50
LLH-1300	CL-7898	2.50
LLH-1375	CL-7899	3.00
LLH-2000	CL-7900	3.00
LLH-2400	CL-7901	Consult
LLH-3500	CL-7902	Formsprag
LLH-5000	CL-7902	

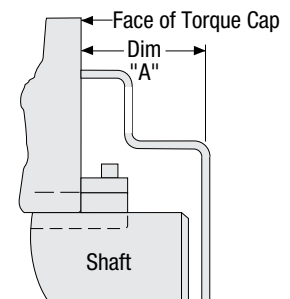

Sizes 700 through 1027

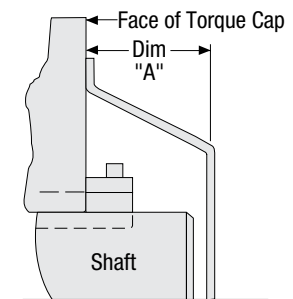

Sizes 1051 through 5000

(i)(2) *Couplings.* Shaft coupling shall be so constructed as to present no hazard from bolts, nuts, setscrews, or revolving surfaces. Bolts, nuts, and set screws will, however, be permitted where they are covered with safety sleeves or where they are used parallel with the shafting and are countersunk or else do not extend beyond the flange of the coupling.

FEDERAL REGISTER,  
VOL.36, NO. 105—  
SATURDAY, MAY 29, 1971

# Holdback Clutches

## LLH

### Torque Arm Installation

The torque arm reaction force is the force which the torque arm stops must resist. Formsprag recommends that the stops be at least 3/4 of the distance (B) away from the center line of the clutch.

The Holdback should be mounted in an orientation so that the weight of the torque arm will keep the torque arm in constant contact with the reacting surface and structure.

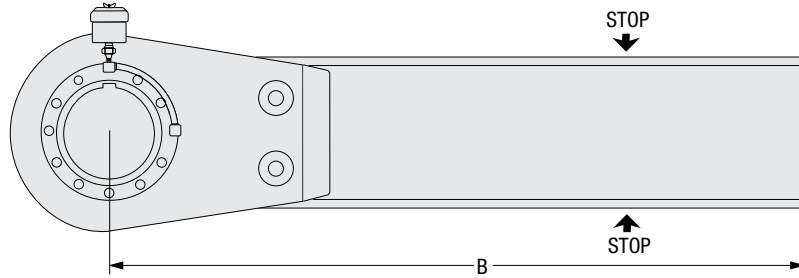

The torque arm reaction force is calculated as follows:

$$\text{Torque Arm Reaction—lbs. (kg)} = \frac{\text{*Rated Backstopping Torque—lb.ft. (Nm)}}{\text{Distance (.75B) of stop from centerline—ft. (m)}}$$

**Note:** Do not restrict torque arm movement in the axial direction.

\*Ratings are shown on page 69 of catalog for applicable holdback.

### Torque Arm Clearance

Torque arm clearance is required on all sides of the torque arm to prevent binding which could cause uneven loading of the holdback bearings.

**Note:** The torque arm must not be rigidly fastened at reaction point.

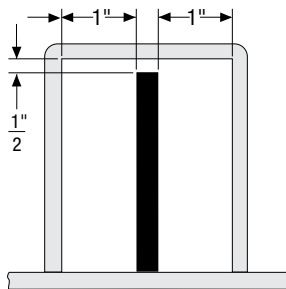

Models 700 thru 900

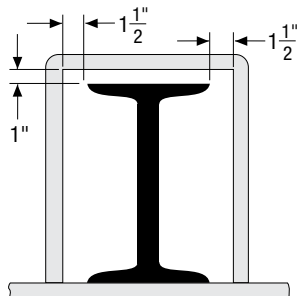

Models 1027 thru 5000

### Specifications

Size	B ft. (m)	.75B ft. (m)	Catalog Torque Values lb.ft. (Nm)	Torque Arm Reaction lb. (kg)
700S	2.5 (.76)	1.88 (.57)	4,000 (5424)	2,150 (975)
750S	2.67 (.81)	2.00 (.61)	6,800 (9221)	3,400 (1542)
800S	2.67 (.81)	2.00 (.61)	11,500 (15594)	5,750 (2608)
900S	3.67 (1.12)	2.75 (.84)	18,000 (24408)	6,550 (2970)
1027S	5.16 (1.57)	3.87 (1.18)	27,000 (36612)	7,000 (3175)
1051S	5.09 (1.55)	3.82 (1.16)	45,000 (61020)	12,000 (5443)
1250S	5.50 (1.68)	4.13 (1.26)	65,000 (88140)	15,750 (7145)
1250R	6.5 (1.98)	4.87 (1.48)	63,000 (85417)	12,936 (7145)
1300S	5.58 (1.71)	4.19 (1.28)	90,000 (122040)	21,500 (9750)
1300R	6.8 (2.0)	5.1 (1.5)	90,000 (122040)	17,647 (9750)
1375S	5.83 (1.78)	4.38 (1.34)	135,000 (183060)	31,000 (14060)
1375R	7.3 (2.2)	5.4 (1.65)	135,000 (183060)	25,000 (14060)
2000S	6.83 (2.08)	5.12 (1.56)	200,000 (271200)	39,500 (17917)
2000R	7.5 (2.3)	5.85 (1.72)	180,000 (244047)	30,770 (17917)
2400S	6.88 (2.10)	5.16 (1.57)	265,000 (359340)	51,500 (23360)
2400R	8.3 (2.5)	6.2 (1.87)	240,000 (325396)	38,700 (23360)
3500S	6.88 (2.10)	5.16 (1.57)	375,000 (508500)	68,000 (30844)
3500R	10 (3.0)	7.5 (2.25)	375,000 (508500)	50,000 (30844)
5000S	6.88 (2.10)	5.16 (1.57)	700,000 (949200)	136,250 (61800)
5000R	12 (3.6)	9 (2.7)	540,000 (732146)	60,000 (27272)
5500R	12 (3.6)	9 (2.7)	720,000 (976271)	80,000 (36363)

### Lubrication

LLH Clutches are normally oil lubricated, see the Installation and Maintenance Bulletin No. 2224, P-222-14 for Models 700 thru 1027 or Bulletin No. 2211, P-222-4 for Models 1051 thru 5000 for the list of approved lubricants.

### Grease Recommended for Long Life Holdbacks

Grease is recommended for vertical shaft applications, but it is not to be used where ambient temperatures are below +20°F. Below +20°F, consult Formsprag.

### Oil Lubrication

The oil level should be checked weekly. To add oil, remove breather cover (entire breather on Model LLH-700), and pour oil into holdback.

Use a recommended oil for the permissible ambient temperature range as specified in the Installation and Maintenance Bulletin No. 2224, P-222-14 for Models 700 through 1027 or Bulletin No. 2211, P-222-4 for Models 1051 through 5000. Formsprag holdbacks are shipped three-fourths full of Mobil DTE Heavy Medium oil.

Holdbacks should be flushed every six months. If holdbacks operate under severe dust conditions, or 24 hours a day, flush every three months.

### Auxiliary Seal Lubrication

Auxiliary seals should be lubricated every three months/monthly if clutch operates under extremely dusty conditions. To relubricate auxiliary seals, pump seals full, through all fittings on both sides, until old grease is purged and clean grease runs out around the entire circumference of seal.

Use a grease selected from the Installation and Maintenance Bulletin No. 2224, P-222-14 for Models 700 through 1027 or Bulletin No. 2211, P-222-4 for Models 1051 through 5000. Auxiliary seals are packed with Fiske Bros. Aero Lubriplate grease prior to shipment.

For additional information, request Lubrication & Maintenance Bulletin A-4032, P-1052 and Installation & Maintenance Bulletin No. 2224, P-222-14 for Models 700 through 1027. For Models 1051 through 5000, request Installation & Maintenance Bulletin No. 2211, P-222-14.

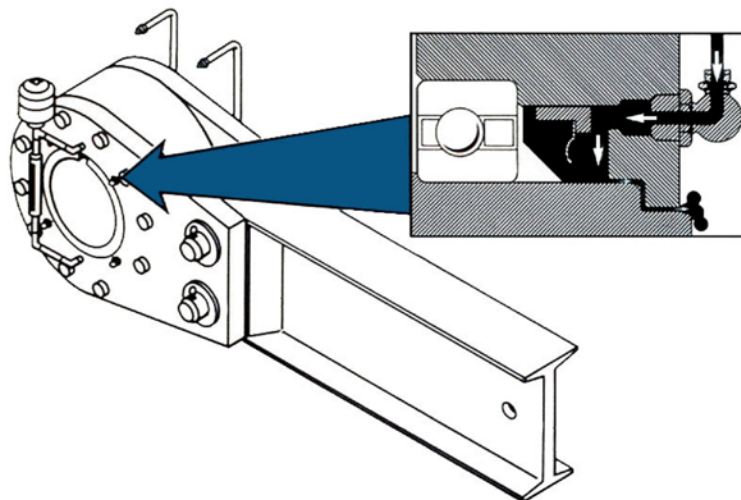
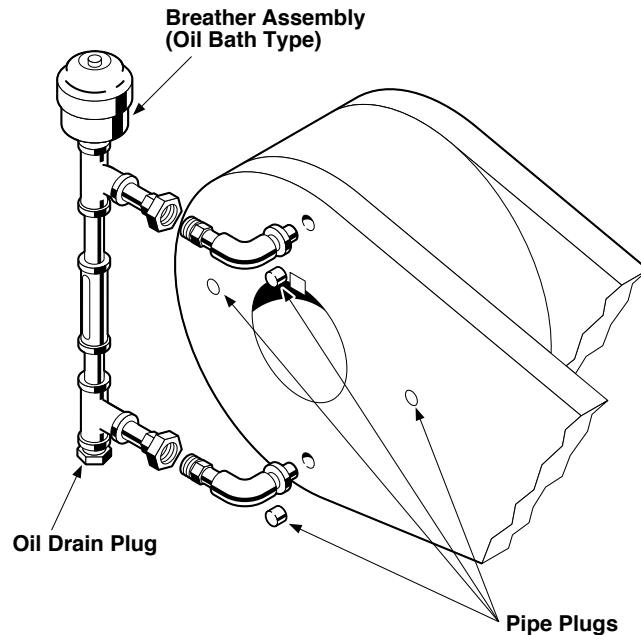

### Storage

Formsprag LLH's are shipped 3/4 full of oil and ready for operation. If the clutch is to be stored for a long period of time (6 months to 2 years), it must be completely filled with oil (Mobil Artic "C")

and stored under a roof at above freezing temperatures. At the customer's request, Formsprag will prepare the clutch for long term storage in accordance with our Spec SP-2877.

# Holdback Clutches

## LLH

### Bore sizes and shaft tolerances

#### English (inches)

Bore and shaft tolerances listed below will give the recommended fit for each size clutch. If the installation requirements make a press fit necessary, never exceed .001" interference fit. For all bore and shaft sizes not listed below use same tolerances and fits as next larger size.

Shaft and key length must be equal to the length of the inner race of the clutch for proper engagement. If the shaft to clutch bore engagement is less than 100% contact Formsprag Engineering.

Nominal Bore	Bore Diameter	Shaft Diameter
1.937	1.9385/1.9395	1.9375/1.9360
2.000	2.0010/2.0020	2.0000/1.9985
2.125	2.1260/2.1270	2.1250/2.1235
2.250	2.2510/2.2525	2.2500/2.2485
2.375	2.3760/2.3770	2.3750/2.3740
2.437	2.4385/2.4400	2.4375/2.4360
2.500	2.5010/2.5025	2.5000/2.4980
2.625	2.6260/2.6275	2.6250/2.6230
2.750	2.7510/2.7525	2.7500/2.7480
2.937	2.9385/2.9400	2.9375/2.9355
3.000	3.0010/3.0025	3.0000/2.9980
3.250	3.2510/3.2525	3.2500/3.2470
3.437	3.4385/3.4400	3.4375/3.4345
3.500	3.5010/3.5025	3.5000/3.4970
3.750	3.7510/3.7525	3.7500/3.7470
3.937	3.9385/3.9400	3.9375/3.9345
4.000	4.0010/4.0025	4.0000/3.9970
4.250	4.2510/4.2530	4.2500/4.2460
4.437	4.4385/4.4405	4.4375/4.4335
4.500	4.5010/4.5030	4.5000/4.4960
4.750	4.7510/4.7530	4.7500/4.7460
4.937	4.9385/4.9405	4.9375/4.9335
5.000	5.0010/5.0030	5.0000/4.9960
5.250	5.2510/5.2530	5.2500/5.2460
5.437	5.4385/5.4405	5.4375/5.4335
5.500	5.5010/5.5030	5.5000/5.4960
5.750	5.7510/5.7530	5.7500/5.7460
5.937	5.9385/5.9405	5.9375/5.9335
6.000	6.0020/6.0040	6.0000/5.9960
6.250	6.2520/6.2540	6.2500/6.2460
6.437	6.4390/6.4410	6.4375/6.4335
6.500	6.5020/6.5040	6.5000/6.4960
6.750	6.7520/6.7540	6.7500/6.7460
6.937	6.9400/6.9420	6.9375/6.9335

**Note:** On models 750 through 5000, Formsprag may elect to supply a stepped key in the event of keyseat distortion during heat treat of inner race.

For bore sizes and recommended shaft tolerances for all other clutch series see page 128.

Nominal Bore	Bore Diameter	Shaft Diameter
7.000	7.003/7.005	7.001/7.000
7.500	7.504/7.506	7.502/7.501
7.750	7.754/7.756	7.752/7.751
8.000	8.004/8.006	8.002/8.001
8.250	8.254/8.256	8.252/8.251
8.500	8.504/8.506	8.502/8.501
8.750	8.754/8.756	8.752/8.751
9.000	9.004/9.006	9.002/9.000
9.250	9.254/9.256	9.252/9.250
9.500	9.504/9.506	9.502/9.500
9.750	9.754/9.756	9.752/9.750
10.000	10.004/10.006	10.002/10.000
10.500	10.504/10.506	10.502/10.500
11.000	11.004/11.006	11.002/11.000
11.500	11.504/11.506	11.502/11.500
12.000	12.004/12.006	12.002/11.999
12.250	12.254/12.256	12.252/12.249
12.500	12.504/12.506	12.502/12.499
13.000	13.004/13.006	13.002/12.999
13.250	13.254/13.256	13.252/13.249
13.500	13.504/13.506	13.502/13.499
13.750	13.754/13.756	13.752/13.749
14.000	14.004/14.006	14.002/13.999
14.250	14.254/14.256	14.252/14.249
14.500	14.504/14.506	14.502/14.499
14.750	14.754/14.756	14.752/14.749
15.000	15.004/15.006	15.002/14.999
15.250	15.254/15.256	15.252/15.249
15.500	15.504/15.506	15.502/15.499
15.750	15.754/15.756	15.752/15.749
16.000	16.004/16.007	16.002/16.000
16.250	16.254/16.257	16.252/16.250
16.500	16.504/16.507	16.502/16.500
16.750	16.754/16.757	16.752/16.750
17.000	17.004/17.007	17.002/17.000
17.250	17.254/17.257	17.252/17.250
17.500	17.504/17.507	17.502/17.500
17.750	17.754/17.757	17.752/17.750
18.000	18.004/18.007	18.002/18.000
18.250	18.254/18.257	18.252/18.250
18.500	18.504/18.507	18.502/18.500
18.750	18.754/18.757	18.752/18.750
19.000	19.004/19.007	19.002/19.000
20.000	20.004/20.007	20.002/20.000

**Metric (millimeters)**

Bore and shaft tolerances listed below will give the recommended fit for each size clutch. If the installation requirements make a press fit necessary, never exceed .025 mm interference fit. For all bore and shaft sizes not listed below use same tolerances and fits as next larger size.

Nominal Bore	Bore Diameter	Shaft Diameter
49.20	49.24/49.26	49.21/49.17
50.80	50.83/50.85	50.80/50.76
53.98	54.00/54.03	53.97/53.94
57.15	57.18/57.21	57.15/57.11
61.90	61.94/61.98	61.91/61.87
63.50	63.53/63.56	63.50/63.45
66.68	66.70/66.74	66.68/66.62
69.85	69.88/69.91	69.85/69.80
74.60	74.64/74.68	74.61/74.56
76.20	76.23/76.26	76.20/76.15
82.55	82.58/82.61	82.55/82.47
87.30	87.34/87.38	87.31/87.24
88.90	88.92/88.96	88.90/88.82
95.25	95.28/95.31	95.25/95.17
100.00	100.04/100.08	100.01/99.94
101.60	101.63/101.66	101.60/101.52
107.95	107.98/108.03	107.95/107.88
112.70	112.74/112.79	112.71/112.61
114.30	114.33/114.38	114.30/114.20
120.65	120.68/120.73	120.65/120.55
125.40	124.44/125.49	125.43/125.31
127.00	127.03/127.08	127.00/126.90
133.35	133.38/133.43	133.35/133.25
138.10	138.14/138.19	138.11/138.01
139.70	139.72/139.78	139.70/139.60
146.05	146.08/146.13	146.05/145.95
150.80	150.84/150.89	150.81/150.71
152.40	152.45/152.50	152.40/152.30
158.75	158.80/158.85	158.75/158.65
163.50	163.55/163.60	163.51/163.41
165.10	165.15/165.20	165.10/164.10
171.45	171.50/171.55	171.45/171.35
176.20	176.28/176.33	176.21/176.11

**Note:** On models 750 thru 5000, Formsprag may elect to supply a stepped key in the event of keyseat distortion during heat treat of inner race.

For bore sizes and recommended shaft tolerances for all other clutch series see page 128.

Nominal Bore	Bore Diameter	Shaft Diameter
177.80	177.88/177.93	177.83/177.80
190.50	190.60/190.66	190.55/190.53
196.85	196.95/197.00	196.90/196.88
203.20	203.30/203.35	203.25/203.23
209.55	209.65/209.70	209.60/209.58
215.90	216.00/216.05	215.95/215.93
222.25	222.35/222.40	222.30/222.28
228.60	228.70/228.75	228.65/228.60
234.95	235.05/235.10	235.00/234.95
241.30	241.40/241.45	241.35/241.30
247.65	247.75/247.80	247.70/247.65
254.00	254.10/254.15	254.05/254.00
266.80	266.80/266.85	266.75/266.70
279.40	279.50/279.55	279.45/279.40
292.10	292.20/292.25	292.15/292.10
304.80	304.90/304.95	304.85/304.77
311.15	311.25/311.30	311.20/311.12
317.50	317.60/317.65	317.55/317.47
330.20	330.30/330.35	330.25/330.17
336.55	336.65/336.70	336.60/336.52
342.90	343.00/343.05	342.95/342.87
349.25	349.35/349.40	349.30/349.22
355.60	355.70/355.75	355.65/355.57
361.95	362.05/362.10	362.00/361.92
368.30	368.40/368.45	368.35/368.27
374.65	374.75/373.80	374.70/374.62
381.00	381.10/381.15	381.05/380.97
387.35	387.45/387.50	387.40/387.32
393.70	393.80/393.85	393.75/393.67
400.05	400.15/400.20	400.10/400.02
406.40	406.50/406.58	406.45/406.40
412.75	412.85/412.93	412.80/412.75
419.10	419.20/419.28	419.15/419.10
425.25	425.55/425.63	425.50/425.45
431.80	431.90/431.98	431.85/431.80
438.15	438.25/438.33	438.20/438.15
444.50	444.60/444.68	444.55/444.50
450.85	450.95/451.01	450.90/450.85
457.20	457.30/457.38	457.25/457.20
463.55	463.65/463.73	463.60/463.55
469.90	470.00/470.08	469.95/469.90
476.25	476.35/476.43	476.30/476.25
482.60	482.70/482.78	482.65/482.60
508.00	508.10/508.18	508.05/508.00

# Backstopping Clutches

## FHB

### Backstopping Ball Bearing Supported, Sprag Clutches



**Model FHB is directly interchangeable with the older FALK® Model BIF external high-speed backstop.**

Model FHB is a high speed, centrifugal throw-out (C/T) Sprag type backstop with internal sealed ball bearings. This self-contained design is completely maintenance free. It requires no re-lubrication, no external control, and no adjustment. It engages instantaneously and automatically to prevent any reverse shaft rotation. Model FHB operates at higher overrunning speeds and holds greater torque loads than competing backstops. A larger number of torque transmitting C/T Sprags reduce the hertzian contact stresses during backstopping leading to longer life than is possible with shoe designs.

#### Specifications

Size	Torque Capacity lb.ft. (Nm)	Overrunning Speed Inner Race RPM		Shipping Weight lb. (kg)
		Min.	Max.	
FHB-10	1,734 (2350)	400	2,400	31 (14)
FHB-20	1,734 (2350)	400	2,000	63 (29)
FHB-60	4,130 (5600)	400	1,800	158 (72)

The FHB backstop is mounted on a through-shaft with its inner race driven by a key, and its integral outer race torque arm prevented from rotating through a clearance fit interface with a fixed reaction pin. The reaction pin may also be used to provide axial restraint of the backstop on the rotating shaft. Typical uses for the Model FHB backstop include inclined conveyors, bucket elevators, and other applications where a rotating shaft must be absolutely prevented from rotating in a reverse direction, as commonly found in mining, aggregates, material handling, and other industries. The high speed capability of the unit make this backstop ideal for mounting on double extended input shafts of gear reducers. The overrunning speed of the rotating shaft should be greater than 400 RPM to assure C/T Sprag “lift-off”.

**Grease Lubricated Backstops**, the Model FHB is shipped from the factory lubricated for life and the ambient operating temperatures range is from -40°F (-40°C) to 150°F (65°C).

**Optional OSHA cover kits** are available for all three sizes. See page 125.

For further information see Service and Installation Instructions (P-222-33-FC, Bulletin 4073).

#### Typical Mounting Arrangements

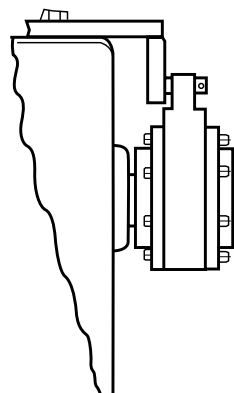

**The Model FHB can be axially restrained by a cotter pin in the reaction pin**

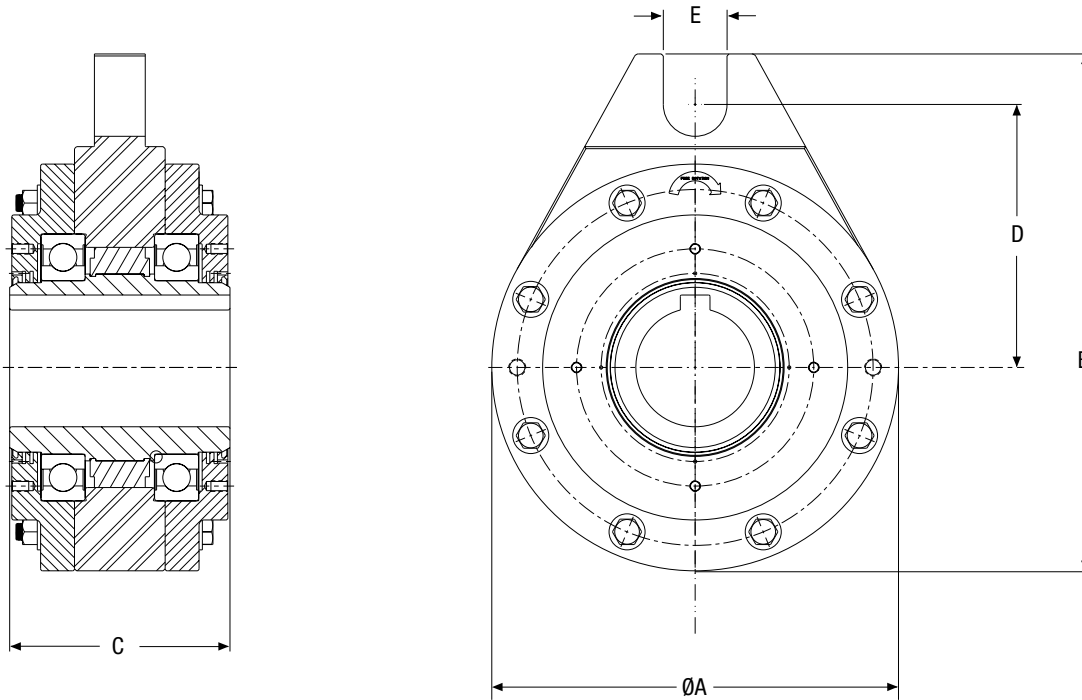

### Dimensions – Formsprag FHB (mm)

Model No.	BORE		A	B	C	D	E
	Min	Max					
FHB-10	1.13 (28.70)	1.88 (47.75)	6.88 (174.75)	8.38 (212.85)	4.13 (104.90)	4.13 (104.90)	0.81 (20.5)
FHB-20	1.75 (44.45)	2.25 (57.15)	8.23 (209.04)	11.26 (286.00)	5.50 (139.70)	6.00 (152.40)	1.25 (31.75)
FHB-60	2.25 (57.15)	3.75 (95.25)	12 (304.80)	15.25 (387.35)	6.50 (165.10)	7.75 (196.85)	1.88 (47.75)

### Dimensions – Falk® BIF (mm)

Model No.	BORE		A	B	C	D
	Min	Max				
10BIF	1.13 (28.70)	1.63 (41.40)	7.28 (184.91)	8.59 (218.19)	4.13 (104.90)	4.13 (104.90)
20BIF	1.75 (44.45)	2.25 (57.15)	10.28 (261.11)	12.27 (311.66)	5.50 (139.70)	6.00 (152.40)
60BIF	2.25 (57.15)	3.75 (95.25)	13.03 (330.96)	15.78 (400.81)	6.50 (165.10)	7.75 (196.85)

### Bore sizes and keyseats inches (mm)

Bore Size	Bore Size	Keyseat	Bore Range	
			Min.	Max.
10	1.13 (28.58)	1/4 x 1/8	1.13 (28.7)	1.88 (47.8)
	1.25 (31.75)			
	1.50 (38.10)			
	1.56 (39.67)			
	1.63 (41.28)			
	1.75 (44.45)			
	1.79 (45.339)			
	2.00 (50.8)			
	2.13 (53.975)			
	2.25 (57.15)			
20	2.25 (57.15)		1.75 (44.5)	2.25 (57.2)
	2.38 (60.325)			
	2.50 (63.5)			
	2.75 (69.85)			
	2.94 (74.6)			
	3.00 (76.2)			
	3.25 (82.55)			
	3.50 (88.9)			
	3.75 (95.25)			
	60			

# Backstopping Clutches

## LCB

### Backstopping Ball Bearing Supported, Sprag Clutches



- Wide speed range between 0 and (LCB-200 3600/ LCB-400 1800 RPM).
- Wide temperature operating range between -13 and 194 °F (-25 and 90 °C).
- Wide bore range for fan shaft (LCB-200 Max 3.5”/ LCB-400 Max 5”) (89mm and 127mm).
- Torque capacity (LCB-200 150 lb.ft (200Nm)/ LCB-400 850 lb.ft (1150Nm).
- Drag torque, negligible, less than 1.5 lb.in.
- Easy to install requiring only LCB-200 1.125” and LCB-400 2” of shaft engagement.
- Lubricated for life (no maintenance required).
- Bearing life L10 is over 200 years.
- Compact design with only LCB-200 2-7/8”/ LCB-400 4.95” required space beyond the shaft end of the fan.
- Self actuated with no power or utility required to operate.
- Shaft mounted design has been tested to over 200% torque capacity.
- Flexible torque arm design.
- Meets ISO “G” 30 Balance

For further information see Installation and Maintenance Bulletin No. A-3041, P-4051.

The Model LCB-200 and 400 were designed to economically meet the problem of windmilling in fan applications.

The Model LCB-200 and 400 are economical low torque clutches which can accommodate a range of shaft diameters between 1-7/8” and 5”.

These clutches can be installed on vertical or horizontal fan shafts without the use of a key. These clutches are maintenance free and easy to install.

### Typical Mounting Arrangements

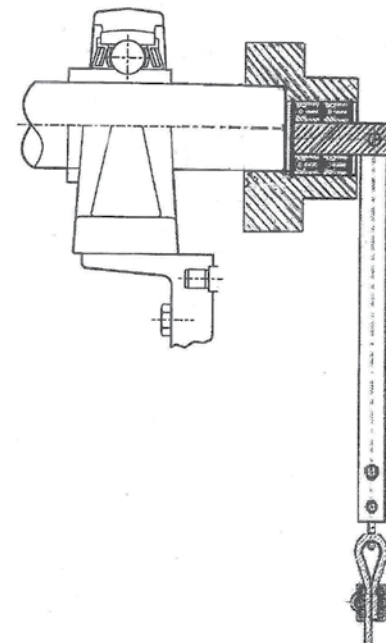

### Specifications

Formsprag Model LCB				
Size	Torque Capacity lb.ft. (Nm)	Max Speed (RPM)	Resistance After Run-in lb.in. (Ncm)	Shipping Weight (lbs)
200	150 (200)	3,600	1.07 (12)	10.0
400	850 (1150)	1,800	1.78 (20)	70.0



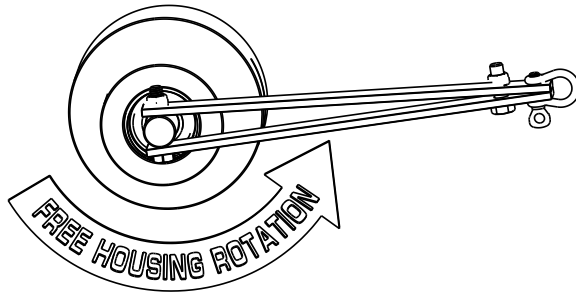

Counterclockwise rotation as shown is left hand.  
Right hand rotation is opposite.

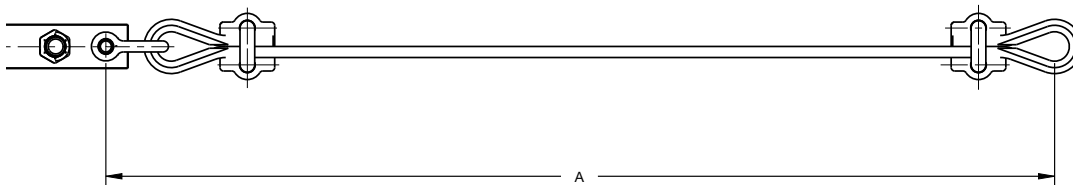
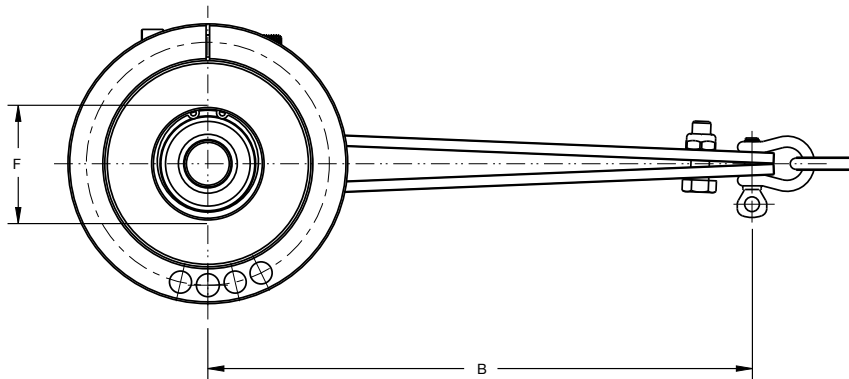
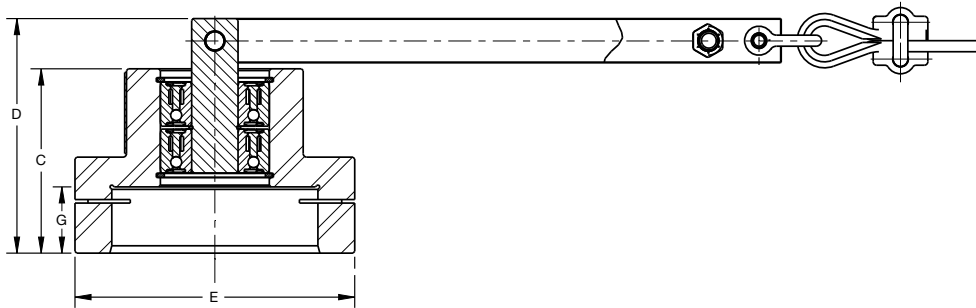

### Dimensions inches (mm)

Model	A	B	C	D	E	F		G
						Min. Bore Size	Max. Bore Size	
LCB-200	Approx. 16	9.25	3.13	3.98	4.75	Ø1.85	Ø3.50	1.12
	(406.40)	(234.95)	(79.50)	(101.09)	(120.65)	(46.99)	(88.90)	(28.45)
LCB-400	Approx. 32	10.75	5.38	6.95	8.00	Ø3.15	Ø5.00	2.00
	(812.80)	(273.05)	(136.65)	(176.53)	(203.20)	(80.01)	(127.00)	(50.80)

# Backstop Clutches

## HFB/VFB

### Backstopping

#### Ball Bearing Supported, Sprag Clutches

#### Horizontal Fan Backstop/Vertical Fan Backstop



**HFB**  
(Horizontal  
Shafts)

**VFB**  
(Vertical  
Shafts)

Models HFB and VFB are backstopping clutching designed to prevent reverse rotation of shafts in applications that have large shaft diameters of up to 6.0 inches and low backstopping torque requirements. HFB & VFB backstops have Sprag clutch technology with high inner race overrunning speed, are ball bearing supported and protected with integral lip seals. The clutch housing is prevented from rotating with a torque arm and is mounted on a stub shaft with a locking ring for easy mounting. Clutches are selected by shaft size and torque requirement.

### Features:

#### Specifications

Size	Torque Capacity lb.ft. (Nm)	Overrunning Speed Max. RPM	Resistance after run-in lb.in. (Ncm)	Maximum Bore in. (mm)	Shipping Weight lb. (kg)	
					HFB	VFB
100	284 (385)	2,000	0.88 (10)	3.00 (76.2)	22 (10)	20 (9)
350	284 (385)	2,000	0.88 (10)	4.50 (114.3)	27 (12.2)	23 (10.3)
450	483 (656)	1,800	0.88 (10)	6.00 (152.4)	30 (13.6)	—

- Wide speed range of 0 to 2,000 RPM
- Wide bore range of 1.0 to 6.0 inches
- Wide torque range of 248 to 483 lb.ft. (337 to 656 Nm)
- Low drag torque of 9 lb.in. (10 Ncm)
- Easy to install, requiring only 1.125 inches of shaft engagement
- Lubricated for life – No regular maintenance required
- Rough bore kits in stock
- Stops wind milling automatically
- Improves both motor and belt life
- Compact design with less than 2.0 inches beyond the shaft end
- Lip sealed backstop for longer life in adverse atmospheres
- Wide temperature operating range of -4°F (-20°C) to 212°F (+100°C)
- Self Actuated – No power or utility required to operate
- Shaft mounting design tested to over 200%
- Patent Pending
- Removable torque arm
- Optional coating available
- No shaft keyseat required for mounting
- Easy installation with a (2) clamping bolt design

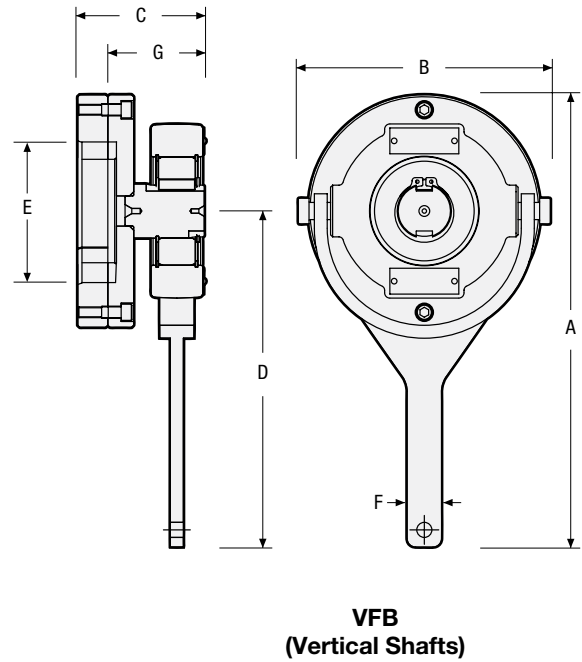
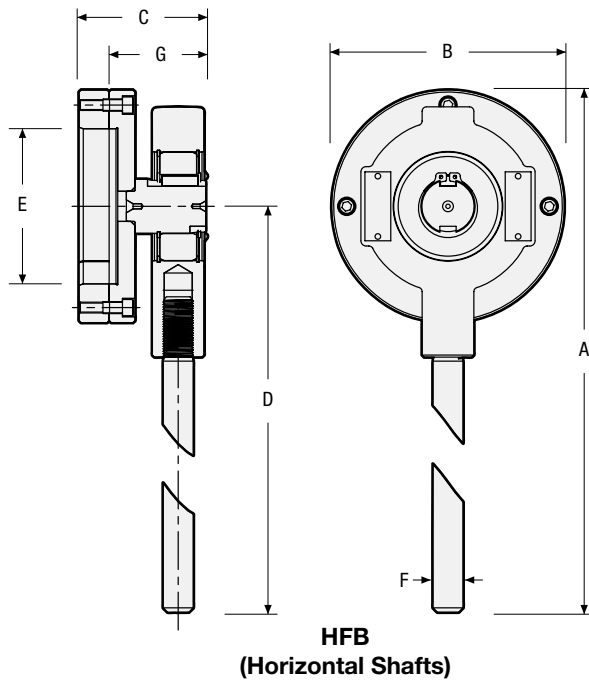

### Dimensions inches (mm)

Model	A	B	C	D	E	F	G
HFB-100	19.25 (488.9)	5.25 (133.4)	4.29 (108)	16.63 (422.4)	1.0/3.0 (25/76)	0.88 (22.2)	2.29 (58.2)
HFB-350	20.00 (508)	6.75 (171.4)	4.29 (108)	16.63 (422.4)	3.0/4.5 (76/114)	0.88 (22.2)	2.29 (58.2)
HFB-450	20.75 (526.4)	8.25 (209.6)	5.20 (132)	16.63 (422.4)	4.5/6.0 (114/152)	0.88 (22.2)	3.20 (80)
VFB-100	12.4 (314.5)	7.3 (185.7)	3.7 (94.0)	9.8 (248.9)	1.0/3.0 (25.4/76.2)	1.0 (25.4)	2.6 (64.8)
VFB-350	13.1 (333.5)	7.3 (185.7)	3.7 (94.0)	9.8 (248.9)	3.0/4.5 (76.2/114.3)	1.0 (25.4)	2.6 (64.8)

### Bore Ranges

Size	in.	(mm)
100	1.0 – 3.0	(25 – 75)
350	3.0 – 4.5	(75 – 114)
450	4.5 – 6.0	(115 – 152)

### Typical Mounting Arrangement

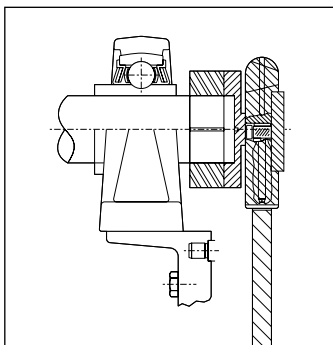

The model VFB & HFB can be secured to a smooth end of shaft without the use of a key using an equine clamping ring design providing a simple and economical solution to wind milling in existing fan applications.

# Modular “Building Block” Clutches

## Building Block System

### Modular Components Offer Extensive Combinations

The Models AL, GFR and RIZ have a modular design that offers a wide range of mounting options. A variety of cover, torque arm and coupling designs that can be assembled to the base clutch result in a mounting flexibility to meet any application.

#### AL

The model AL..clutch assembled with the F2 and D2 covers provides a versatile clutch assembly. The F2 cover provides mounting holes countersunk from the outboard side which are used to secure and drive a gear or pulley mounted over the outer race. This mounting configuration provides the highest radial load capacity as the line of force from the gear or sprocket is located between the clutch bearings. The D2 cover encloses the other end of the clutch for through shaft mounting.



#### GFR

The model GFR clutch assembled with the F3 and F4 covers results in an excellent low speed backstop. The F3 cover encloses one side of the clutch and provides the torque arm with integrated restraining bolt necessary for backstopping applications. The F4 cover encloses the other side of the clutch and provides extra room for end of shaft restraint as well as added oil capacity.

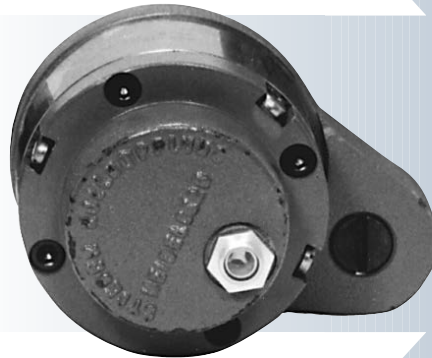

#### RINZ

The model RINZ clutch assembled with the G5 covers on both sides provides a durable easy-to-use design. The G5 cover provides axial restraint of a gear or pulley mounted on the outer race. Torque is transmitted to the gear or pulley by the key located in the outer race outside keyseat.

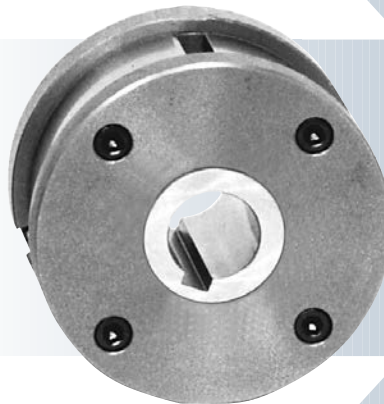

# Modular "Building Block" Clutches

## Building Block System Clutch and Cover Combinations

Covers

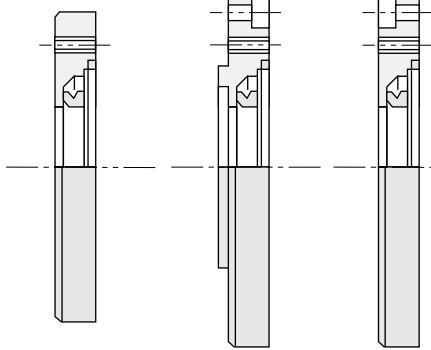

F7

F4

F2

Clutch

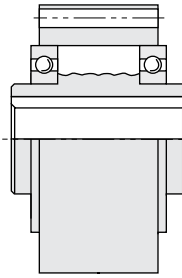

AL/ALM  
ALP/ALPM

Covers

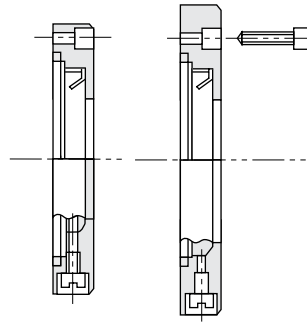

D2

D7

Covers

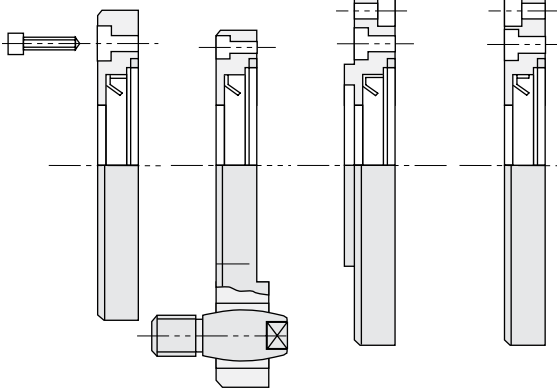

F5

F3

F7

F1

Clutch

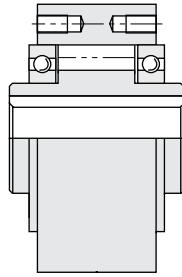

GFR, GFRN

Covers

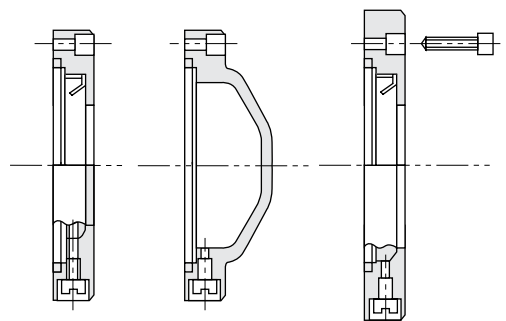

F2

F4

F6

Covers

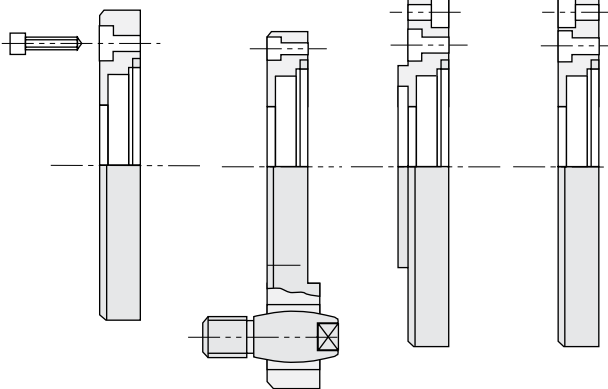

G5

G3

G7

G1

Clutch

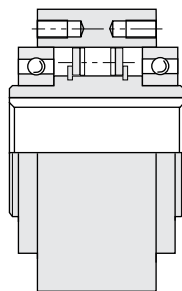

RIZ  
RINZ

Covers

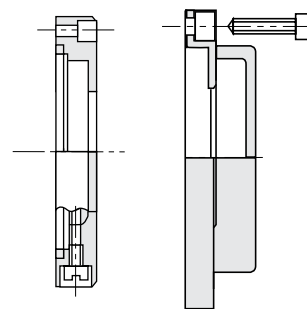

G2

G4

# Modular “Building Block” Clutches

## AL/ALM

### Overrunning, Indexing Ball Bearing Supported, Ramp & Roller Clutches



The model AL and ALM clutches are part of a Modular Building Block System. They are a ramp & roller type clutch that is ball bearing supported. Covers are used to transmit the torque and enclose the clutch, making it self-contained. A variety of cover designs are available and the cover combination selected would be based upon the drive arrangement. The bearings in this design cannot accept axial loads. These clutches are primarily used in overrunning and indexing applications. These clutches are oil lubricated.

This clutch is designed for oil lubrication. For grease lubrication, reduce the maximum overrunning speed to 50% of listed value.

For bolt tightening torque values, see page 134.

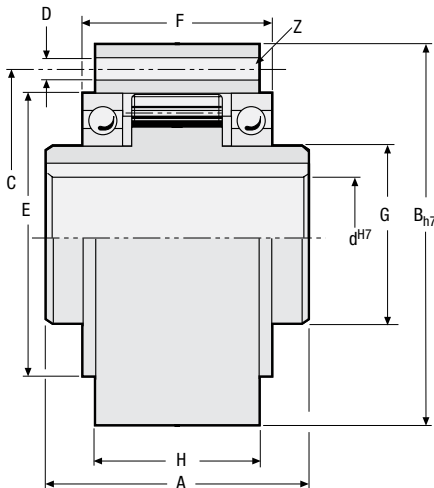

### Specifications

Model	Size	Torque Capacity lb.ft. (Nm)	Overrunning Speed Max. RPM		Resistance after run-in lb.in. (Ncm)	Shipping Weight lb. (kg)
			Inner Race	Outer Race		
AL	12	41 (55)	2,500	7,200	0.3 (3.4)	1.3 (0.6)
	15	92 (125)	1,900	6,500	0.3 (4.1)	2.0 (0.9)
	20	134 (181)	1,600	5,600	0.7 (8)	2.6 (1.2)
	25	213 (288)	1,400	4,500	1.3 (14)	4.0 (1.8)
	30	369 (500)	1,300	4,100	2.1 (23)	5.3 (2.4)
	35	535 (725)	1,100	3,800	5.4 (60)	6.8 (3.1)
	40	756 (1025)	950	3,400	6.5 (72)	10.6 (4.8)
	45	830 (1125)	900	3,200	12.6 (140)	11 (4.9)
	50	1,568 (2125)	850	2,800	16.2 (180)	16 (6.9)
	55	1,937 (2625)	720	2,650	17.1 (190)	20 (9)
	60	2,583 (3500)	680	2,450	21.6 (240)	24 (11)
	70	4,244 (5750)	580	2,150	28.8 (320)	31 (14)
	80	6,273 (8500)	480	1,900	29.7 (330)	40 (18)
	90	10,701 (14500)	380	1,700	58.5 (650)	60 (27)
	100	14,760 (20000)	350	1,450	74.7 (830)	101 (46)
120	23,063 (31250)	250	1,250	97.2 (1080)	139 (63)	
150	51,660 (70000)	180	980	111.6 (1240)	282 (128)	
200	129,150 (175000)	120	750	342 (3800)	650 (293)	
250	212,175 (287500)	100	620	549 (6100)	1,034 (469)	
ALM	25	286 (388)	1,100	2,800	1.9 (22)	3.7 (1.8)
	30	434 (588)	1,000	2,500	3.3 (37)	5.3 (2.5)
	35	618 (838)	900	2,400	5.9 (66)	7.0 (3.2)

# Modular “Building Block” Clutches

AL/ALM

## Dimensions inches (mm)

Model	Size	A	B <sub>h7</sub>	C	D	E	F	G	H <sup>(1)</sup>	Z
				Bolt Circle Dia.	Bolt Hole Dia. (No. Holes)					
AL	12	1.654 (42)	2.44 (62)	2.008 (51)	.217 (3) (5.5)	1.654 (42)	1.063 (27)	.787 (20)	.799 (20.3)	3
	15	2.047 (52)	2.67 (68)	2.205 (56)	.217 (3) (5.5)	1.850 (47)	1.343 (34.1)	.984 (25)	1.193 (30.3)	3
	20	2.244 (57)	2.953 (75)	2.520 (64)	.217 (4) (5.5)	2.165 (55)	1.539 (39.1)	1.181 (30)	1.350 (34.3)	4
	25	2.362 (60)	3.543 (90)	3.071 (78)	.217 (6) (5.5)	2.677 (68)	1.657 (42.1)	1.575 (40)	1.469 (37.3)	6
	30	2.677 (68)	3.937 (100)	3.425 (87)	.260 (6) (6.6)	2.953 (75)	1.933 (49.1)	1.772 (45)	1.744 (44.3)	6
	35	2.913 (74)	4.331 (110)	3.780 (96)	.260 (6) (6.6)	3.150 (80)	2.130 (54.1)	1.969 (50)	1.902 (48.3)	6
	40	3.386 (86)	4.921 (125)	4.252 (108)	.354 (6) (9)	3.543 (90)	2.445 (62.1)	2.165 (55)	2.217 (56.3)	6
	45	3.386 (86)	5.118 (130)	4.409 (112)	.354 (8) (9)	3.740 (95)	2.445 (62.1)	2.362 (60)	2.217 (56.3)	8
	50	3.622 (92)	5.906 (150)	5.197 (132)	.354 (8) (9)	4.331 (110)	2.720 (69.1)	2.756 (70)	2.492 (63.3)	8
	55	4.094 (104)	6.299 (160)	5.433 (138)	.433 (8) (11)	4.528 (115)	2.878 (73.1)	2.953 (75)	2.638 (67)	8
	60	4.488 (114)	6.693 (170)	5.906 (150)	.433 (10) (11)	4.921 (125)	3.307 (84)	3.150 (80)	3.071 (78)	10
	70	5.276 (134)	7.480 (190)	6.496 (165)	.433 (10) (11)	5.512 (140)	4.056 (103)	3.543 (90)	3.740 (95)	10
	80	5.669 (144)	8.268 (210)	7.283 (185)	.433 (10) (11)	6.299 (160)	4.882 (108)	4.133 (105)	3.937 (100)	10
	90	6.220 (158)	9.055 (230)	8.110 (206)	.551 (10) (14)	7.087 (180)	5.630 (125)	4.724 (120)	4.528 (115)	10
	100	7.165 (182)	10.630 (270)	9.449 (240)	.709 (10) (18)	8.268 (210)	5.157 (131)	5.512 (140)	4.724 (120)	10
120	7.953 (202)	12.205 (310)	10.945 (278)	.709 (12) (18)	9.449 (240)	5.984 (152)	6.299 (160)	5.512 (140)	12	
150	9.685 (246)	15.748 (400)	14.173 (360)	.866 (12) (22)	12.205 (310)	7.717 (190)	7.874 (200)	7.087 (180)	12	
200	12.834 (326)	20.472 (520)	18.110 (460)	1.024 (18) (26)	15.748 (400)	10.433 (265)	10.236 (260)	9.449 (240)	18	
250	15.591 (396)	24.016 (610)	21.457 (545)	1.299 (20) (33)	18.898 (480)	12.992 (330)	12.598 (320)	11.811 (300)	20	
ALM	25	2.362 (60)	3.543 (90)	3.071 (78)	.217 (6) (5.5)	2.677 (68)	1.657 (42.1)	1.575 (40)	1.468 (37.3)	6
	30	2.677 (68)	3.937 (100)	3.425 (87)	.260 (6) (6.6)	2.953 (75)	1.933 (49.1)	1.772 (45)	1.744 (44.3)	6
	35	2.913 (74)	4.331 (110)	3.780 (96)	.260 (6) (6.6)	3.150 (80)	2.130 (54.1)	1.969 (50)	1.902 (48.3)	6

## Bore sizes and keyseats inches (mm)

Size	d <sup>H7</sup> Bore Size	Keyseat*	Bore Range	
			Min.	Max.
12	.47 (12)	(4 X 1.8)	.354	.550
15	.59 (15)	(5 X 2.3)	.433	.689
20	.79 (20)	(6 X 2.8)	.433	.689
25	.98 (25)	(8 X 3.3)	.551	1.102
30	1.18 (30)	(8 X 3.3)	.748	1.338
35	1.38 (35)	(10 X 3.3)	.944	1.496
40	1.57 (40)	(12 X 3.3)	1.102	1.692
45	1.77 (45)	(14 X 3.8)	1.102	1.811
50	1.97 (50)	(14 X 3.8)	1.496	2.165
55	2.17 (55)	(16 X 4.3)	1.496	2.362
60	2.36 (60)	(18 X 4.4)	1.890	2.440
70	2.76 (70)	(20 X 4.9)	1.890	2.874
80	3.15 (80)	(22 X 5.4)	2.165	3.385
90	3.54 (90)	(25 X 5.4)	2.362	3.779
100	3.94 (100)	(28 X 6.4)	2.755	4.488
120	4.72 (120)	(32 X 7.4)	3.149	4.803
150	5.91 (150)	(36 X 8.4)	3.937	6.614
200	7.87 (200)	—	4.724	8.740
250	9.84 (250)	—	5.905	10.708
25	.98 (25)	(8 X 3.3)	.551	1.102
30	1.18 (30)	(8 X 3.3)	.748	1.338
35	1.38 (35)	(10 X 3.3)	.944	1.496

### Notes:

<sup>(1)</sup> The dimension “H” for models 12 to 50 have sealing discs. Both sides add .010 inches (.25 mm) for each disc. From model 55 and up, without sealing discs, use “O” ring seals.

\* For keyseat sizes see DIN6885.1 table on page 129.

# Modular “Building Block” Clutches

## AL..F2D2, AL..F4D2; ALM..F2D2, ALM..F4D2

Overrunning, Indexing, Backstopping Ball Bearing Supported, Ramp & Roller Clutches

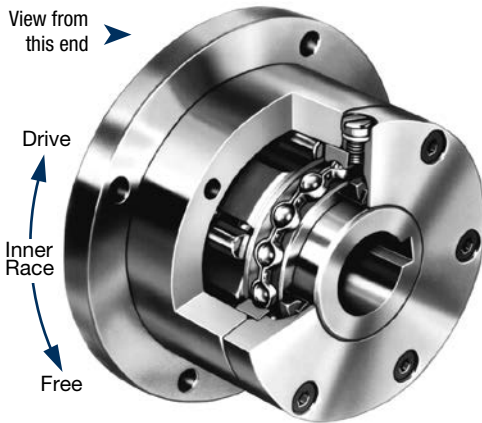

*Right Hand rotation shown.  
(Left Hand opposite.)*

*Specify direction of rotation when ordering.*

The Model ALM clutch is a modified design for higher torque and lower overrunning speed applications.

This clutch is designed for oil lubrication. For grease lubrication, reduce the maximum overrunning speed to 50% of listed value.

### Specifications

Model	Size	Torque Capacity lb.ft. (Nm)	Overrunning Speed Max. RPM		Resistance after run-in lb.in. (Ncm)	Shipping Weight lb. (kg)
			Inner Race	Outer Race		
AL..F2D2 AL..F4D2	12	41 (55)	2,500	7,200	1.0 (11)	1.98 (0.9)
	15	92 (125)	1,900	6,500	1.3 (15)	2.87 (1.3)
	20	134 (181)	1,600	5,600	1.6 (18)	3.75 (1.7)
	25	213 (288)	1,400	4,500	3.2 (36)	5.73 (2.6)
	28	369 (500)	1,300	4,100	.35 (4)	7.72 (3.5)
	30	369 (500)	1,300	4,100	.35 (4)	7.72 (3.5)
	35	535 (725)	1,100	3,800	5.3 (60)	9.92 (4.5)
	40	756 (1025)	950	3,400	7.4 (84)	15.21 (6.9)
	45	830 (1125)	900	3,200	8.3 (94)	15.66 (7.1)
	50	1,568 (2125)	850	2,800	11.3 (128)	22.27 (10.1)
	55	1,937 (2625)	720	2,650	13.3 (150)	28.89 (13.1)
	60	2,583 (3500)	680	2,450	14.2 (160)	34.40 (15.6)
	70	4,244 (5750)	580	2,150	31.9 (360)	44.98 (20.4)
	80	6,273 (8500)	480	1,900	31.9 (360)	58.87 (26.7)
	90	10,701 (14500)	380	1,700	60.2 (680)	86.00 (39)
	100	14,760 (20000)	350	1,450	77.9 (880)	145.53 (66)
	120	23,063 (31250)	250	1,250	106.2 (1200)	200.66 (91)
150	51,660 (70000)	180	980	119.5 (1350)	410.13 (186)	
200	129,150 (175000)	120	750	371.7 (4200)	937.12 (425)	
250	212,175 (287500)	100	620	575.3 (6500)	1,499.4 (680)	
ALM..F2D2 ALM..F4D2	25	286 (388)	1,100	2,800	3.6 (41)	5.95 (2.7)
	30	434 (588)	1,000	2,500	5.7 (64)	8.05 (3.65)
	35	618 (838)	900	2,400	6.7 (76)	10.36 (4.7)

**Note:** When ordering, please specify direction of rotation.



# Modular “Building Block” Clutches

## AL..F2D2, AL..F4D2; ALM..F2D2, ALM..F4D2

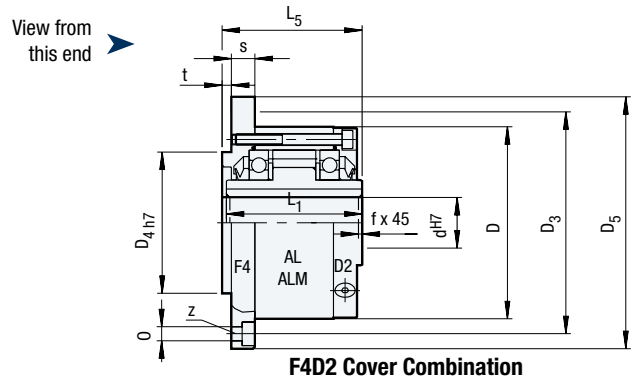
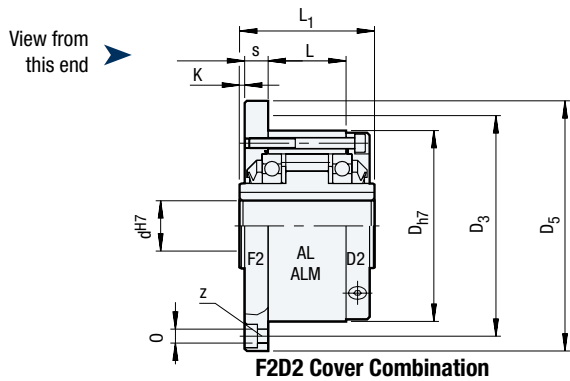

### Dimensions inches (mm)

Model	Size	d <sup>H7</sup>	D <sub>h7</sub>	L <sub>1</sub>	D <sub>5</sub>	D <sub>3</sub>	z	0	D <sub>4h7</sub>	t	L <sub>5</sub>	K	s	f
AL..F2D2 AL..F4D2	12	0.47 (12)	2.44 (62)	1.65 (42)	3.35 (85)	2.83 (72)	3	0.22 (5.5)	1.65 (42)	0.12 (3)	1.73 (44)	0.02 (0.5)	0.41 (10.3)	0.02 (0.5)
	15	0.59 (15)	2.68 (68)	2.05 (52)	3.62 (92)	3.07 (78)	3	0.22 (5.5)	1.85 (47)	0.12 (3)	2.13 (54)	0.02 (0.5)	0.41 (10.3)	0.03 (0.8)
	20	0.79 (20)	2.95 (75)	2.24 (57)	3.86 (98)	3.35 (85)	4	0.22 (5.5)	2.17 (55)	0.12 (3)	2.32 (59)	0.02 (0.5)	0.43 (10.8)	0.03 (0.8)
	25	0.98 (25)	3.54 (90)	2.36 (60)	4.65 (118)	4.09 (104)	6	0.26 (6.6)	2.68 (68)	0.12 (3)	2.44 (62)	0.02 (0.5)	0.41 (10.5)	0.04 (1)
	28	1.18 (30)	3.94 (100)	2.68 (68)	5.04 (128)	4.49 (114)	6	0.26 (6.6)	2.95 (75)	0.12 (3)	2.76 (70)	0.02 (0.5)	0.44 (11.3)	0.04 (1)
	30	1.18 (30)	3.94 (100)	2.68 (68)	5.04 (128)	4.49 (114)	6	0.26 (6.6)	2.95 (75)	0.12 (3)	2.76 (70)	0.02 (0.5)	0.44 (11.3)	0.04 (1)
	35	1.38 (35)	4.33 (110)	2.91 (74)	5.43 (138)	4.88 (124)	6	0.26 (6.6)	3.15 (80)	0.14 (3.5)	2.99 (76)	0.04 (1)	0.46 (11.8)	0.04 (1)
	40	1.57 (40)	4.92 (125)	3.39 (86)	6.30 (160)	5.59 (142)	6	0.35 (9)	3.54 (90)	0.14 (3.5)	3.46 (88)	0.04 (1)	0.54 (13.8)	0.06 (1.5)
	45	1.77 (45)	5.12 (130)	3.39 (86)	6.50 (165)	5.75 (146)	8	0.35 (9)	3.74 (95)	0.14 (3.5)	3.46 (88)	0.04 (1)	0.54 (13.8)	0.06 (1.5)
	50	1.97 (50)	5.91 (150)	3.62 (92)	7.28 (185)	6.54 (166)	8	0.35 (9)	4.33 (110)	0.16 (4)	3.70 (94)	0.04 (1)	0.50 (12.8)	0.06 (1.5)
	55	2.17 (55)	6.30 (160)	4.09 (104)	8.03 (204)	7.17 (182)	8	0.43 (11)	4.53 (115)	0.16 (4)	4.17 (106)	0.06 (1.5)	0.66 (16.8)	0.08 (2)
	60	2.36 (60)	6.69 (170)	4.49 (114)	8.43 (214)	7.56 (192)	10	0.43 (11)	4.92 (125)	0.16 (4)	4.57 (116)	0.06 (1.5)	0.64 (16.3)	0.08 (2)
	70	2.76 (70)	7.48 (190)	5.28 (134)	9.21 (234)	8.35 (212)	10	0.43 (11)	5.51 (140)	0.16 (4)	5.35 (136)	0.06 (1.5)	0.70 (17.8)	0.10 (2.5)
	80	3.15 (80)	8.27 (210)	5.67 (144)	10.00 (254)	9.13 (232)	10	0.43 (11)	6.30 (160)	0.16 (4)	5.76 (146.3)	0.06 (1.5)	0.80 (20.3)	0.10 (2.5)
	90	3.54 (90)	9.06 (230)	6.22 (158)	10.94 (278)	10.00 (254)	10	0.55 (14)	7.09 (180)	0.18 (4.5)	6.34 (161)	0.06 (1.5)	0.79 (20)	0.12 (3)
	100	3.94 (100)	10.63 (270)	7.17 (182)	13.19 (335)	12.01 (305)	10	0.71 (18)	8.27 (210)	0.20 (5)	7.24 (184)	0.10 (2.5)	1.10 (28)	0.12 (3)
120	4.72 (120)	12.20 (310)	7.95 (202)	14.76 (375)	13.58 (345)	12	0.71 (18)	9.45 (240)	0.20 (5)	8.03 (204)	0.10 (2.5)	1.12 (28.5)	0.12 (3)	
150	5.91 (150)	15.75 (400)	9.69 (246)	19.09 (485)	17.52 (445)	12	0.87 (22)	12.20 (310)	0.20 (5)	9.80 (249)	0.10 (2.5)	1.22 (31)	0.16 (4)	
200	7.87 (200)	20.47 (520)	12.83 (326)	24.61 (625)	22.24 (565)	18	1.02 (26)	15.75 (400)	0.20 (5)	12.91 (328)	0.12 (3)	1.57 (40)	0.20 (5)	
250	9.84 (250)	24.02 (610)	15.59 (396)	29.13 (740)	26.77 (680)	20	1.30 (33)	18.90 (480)	0.20 (5)	15.67 (398)	0.12 (3)	1.77 (45)	0.20 (5)	
ALM..F2D2 ALM..F4D2	25	.098 (25)	3.54 (90)	2.36 (60)	4.65 (118)	4.09 (104)	4	0.26 (6.6)	2.68 (68)	0.12 (3)	2.44 (62)	0.02 (0.5)	0.41 (10.5)	0.04 (1)
	30	1.18 (30)	3.94 (100)	2.68 (68)	5.04 (128)	4.49 (114)	6	0.26 (6.6)	2.95 (75)	0.12 (3)	2.76 (70)	0.02 (0.5)	0.44 (11.3)	0.04 (1)
	35	1.38 (35)	4.33 (110)	2.91 (74)	5.43 (138)	4.88 (124)	6	0.26 (6.6)	3.15 (80)	0.14 (3.5)	2.99 (76)	0.04 (1)	0.46 (11.8)	0.04 (1)

Note: For bore and keyseat information see page 93.

# Modular “Building Block” Clutches

## ALP..F7D7, ALPM..F7D7

### Overrunning, Indexing Ball Bearing Supported, Ramp & Roller Clutches

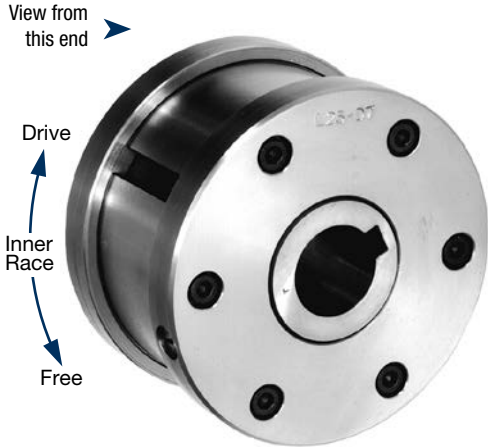

Right Hand rotation shown.  
(Left Hand opposite.)

Specify direction of rotation when ordering.

Model ALP..F7D7 is a ramp & roller type clutch, self-contained, sealed and bearing supported using two 160 Series bearings. Unit is shipped oil lubricated.

This cover combination is mostly used as an overrunning or indexing clutch.

A keyway is machined on the outer race for the connection to the drive or driven member centered on its outside.

D7 cover is used to close the unit. It is equipped with two screws for oil filling, drain and level.

The shaft seal is a V-ring type. Cover and seal have been designed to provide sealing with minimum drag torque.

We recommend that the unit be supplied assembled.

This clutch is designed for oil lubrication. For grease lubrication, reduce the maximum overrunning speed to 50% of listed value.

### Specifications

Model	Size	Torque Capacity lb.ft. (Nm)	Overrunning Speed Max. RPM		Resistance after run-in lb.in. (Ncm)	Shipping Weight lb. (kg)
			Inner Race	Outer Race		
ALP.. F7D7	12	41 (55)	2,500	7,200	1.0 (11)	2.21 (1)
	15	92 (125)	1,900	6,500	1.3 (15)	3.09 (1.4)
	20	134 (181)	1,600	5,600	1.6 (18)	4.19 (1.9)
	25	213 (288)	1,400	4,500	3.2 (36)	6.17 (2.8)
	28	369 (500)	1,300	4,100	4.0 (45)	8.16 (3.7)
	30	369 (500)	1,300	4,100	4.1 (45)	8.16 (3.7)
	35	535 (725)	1,100	3,800	5.4 (60)	10.36 (4.7)
	40	756 (1025)	950	3,400	7.4 (84)	15.66 (7.1)
	45	830 (1125)	900	3,200	8.3 (94)	16.32 (7.4)
	50	1,568 (2125)	850	2,800	11.3 (128)	22.93 (10.4)
	55	1,937 (2625)	720	2,650	13.3 (150)	29.55 (13.4)
	60	2,583 (3500)	680	2,450	14.2 (160)	35.06 (15.9)
	70	4,244 (5750)	580	2,150	31.9 (360)	45.86 (20.8)
	80	6,273 (8500)	480	1,900	31.9 (360)	59.76 (27.1)
	90	10,701 (14500)	380	1,700	60.2 (680)	86.88 (39.4)
100	14,760 (20000)	350	1,450	77.9 (880)	146.41 (66.4)	
120	23,063 (31250)	250	1,250	106.2 (1200)	201.76 (91.5)	
150	51,660 (70000)	180	980	119.5 (1350)	412.34 (187)	
200	129,150 (175000)	120	750	371.7 (4200)	948.15 (430)	
250	212,175 (287500)	100	620	575.3 (6500)	1,517.04 (688)	
ALPM.. F7D7	25	286 (388)	1,100	2,800	3.6 (41)	6.39 (2.9)
	30	434 (588)	1,000	2,500	5.7 (64)	8.49 (3.85)
	35	618 (838)	900	2,400	6.7 (76)	10.80 (4.9)

**Note:** When ordering, please specify direction of rotation.

# Modular “Building Block” Clutches

## ALP..F7D7, ALPM..F7D7

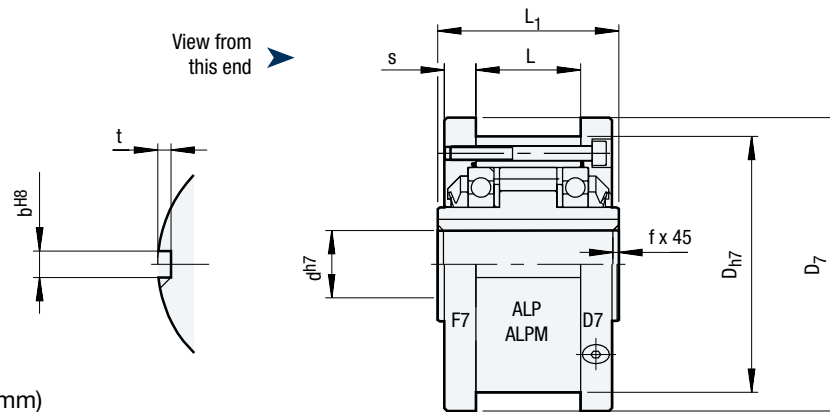

Dimensions inches (mm)

Model	Size	d <sup>H7</sup>	D <sup>H7</sup>	L <sub>1</sub>	D <sub>7</sub>	s	L	b <sup>H8</sup>	t	f
ALP.. F7D7	12	0.47 (12)	2.44 (62)	1.65 (42)	2.76 (70)	0.41 (10.4)	0.79 (20)	0.16 (4)	0.09 (2.4)	0.02 (0.5)
	15	0.59 (15)	2.68 (68)	2.05 (52)	2.99 (76)	0.45 (11.4)	1.10 (28)	0.20 (5)	0.11 (2.9)	0.03 (0.8)
	20	0.79 (20)	2.95 (75)	2.24 (57)	3.31 (84)	0.43 (10.9)	1.34 (34)	0.24 (6)	0.14 (3.5)	0.03 (0.8)
	25	0.98 (25)	3.54 (90)	2.36 (60)	3.90 (99)	0.47 (11.9)	1.38 (35)	0.31 (8)	0.16 (4.1)	0.04 (1)
	28	1.18 (30)	3.94 (100)	2.68 (68)	4.29 (109)	0.47 (11.9)	1.69 (43)	0.31 (8)	0.16 (4.1)	0.04 (1)
	30	1.18 (30)	3.94 (100)	2.68 (68)	4.29 (109)	0.47 (11.9)	1.69 (43)	0.31 (8)	0.16 (4.1)	0.04 (1)
	35	1.38 (35)	4.33 (110)	2.91 (74)	4.69 (119)	0.53 (13.4)	1.77 (45)	0.39 (10)	0.19 (4.7)	0.04 (1)
	40	1.57 (40)	4.92 (125)	3.39 (86)	5.31 (135)	0.61 (15.4)	2.09 (53)	0.47 (12)	0.19 (4.9)	0.06 (1.5)
	45	1.77 (45)	5.12 (130)	3.39 (86)	5.51 (140)	0.61 (15.4)	2.09 (53)	0.55 (14)	0.22 (5.5)	0.06 (1.5)
	50	1.97 (50)	5.91 (150)	3.62 (92)	6.30 (160)	0.51 (12.9)	2.52 (64)	0.55 (14)	0.22 (5.5)	0.06 (1.5)
	55	2.17 (55)	6.30 (160)	4.09 (104)	6.69 (170)	0.69 (17.5)	2.60 (66)	0.63 (16)	0.24 (6.2)	0.08 (2)
	60	2.36 (60)	6.69 (170)	4.49 (114)	7.17 (182)	0.65 (16.5)	3.07 (78)	0.71 (18)	0.27 (6.8)	0.08 (2)
	70	2.76 (70)	7.48 (190)	5.28 (134)	7.95 (202)	0.71 (18)	3.74 (95)	0.79 (20)	0.29 (7.4)	0.10 (2.5)
	80	3.15 (80)	8.27 (210)	5.67 (144)	8.74 (222)	0.81 (20.5)	3.94 (100)	0.87 (22)	0.33 (8.5)	0.10 (2.5)
	90	3.54 (90)	9.06 (230)	6.22 (158)	9.53 (242)	0.79 (20)	4.53 (115)	0.98 (25)	0.34 (8.7)	0.12 (3)
	100	3.94 (100)	10.63 (270)	7.17 (182)	11.10 (282)	1.12 (28.5)	4.72 (120)	1.10 (28)	0.39 (9.9)	0.12 (3)
	120	4.72 (120)	12.20 (310)	7.95 (202)	12.68 (322)	0.89 (22.5)	5.98 (152)	1.26 (32)	0.44 (11.1)	0.12 (3)
	150	5.91 (150)	15.75 (400)	9.69 (246)	16.22 (412)	1.22 (31)	7.09 (180)	1.42 (36)	0.48 (12.3)	0.16 (4)
	200	7.87 (200)	20.47 (520)	12.83 (326)	21.26 (540)	1.57 (40)	9.45 (240)	1.77 (45)	0.59 (15)	0.20 (5)
	250	9.84 (250)	24.02 (610)	15.59 (396)	24.80 (630)	1.77 (45)	11.8 (300)	1.77 (45)	0.59 (15)	0.20 (5)
ALPM.. F7D7	25	0.98 (25)	3.54 (90)	2.36 (60)	3.90 (99)	0.47 (11.9)	1.38 (35)	0.31 (8)	0.16 (4.1)	0.04 (1)
	30	1.18 (30)	3.94 (100)	2.68 (68)	4.29 (109)	0.47 (11.9)	1.69 (43)	0.31 (8)	0.16 (4.1)	0.04 (1)
	35	1.38 (35)	4.33 (110)	2.91 (74)	4.69 (119)	0.53 (13.4)	1.77 (45)	0.39 (10)	0.19 (4.7)	0.04 (1)

Note: For bore and keyseat information see page 93.

# Modular “Building Block” Clutches

## GFR®/GFRN

### Overrunning, Indexing, Backstopping Ball Bearing Supported, Ramp & Roller Clutches

#### GFR

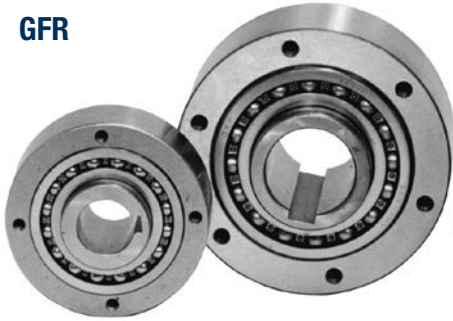

#### GFRN

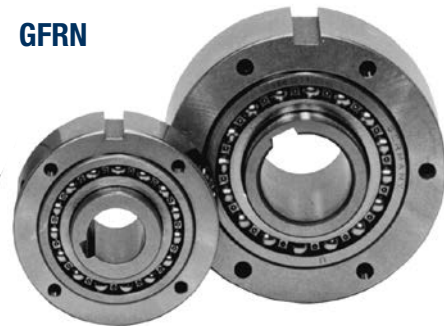

The GFR and GFRN are part of the Stieber modular system. They are bearing supported, using two 160 Series bearings, and require oil lubrication. These units may be used in designs providing oil lubrication and sealing as shown on the following pages.

The bearings must not be axially stressed. Typically, models GFR and GFRN are used with the F series covers that are designed to transmit torque and retain oil lubrication.

Usually, these covers are used in pairs according to combinations shown on the following pages.

The outer race of the GFR model is designed to support and center any

component bored to H7 tolerance. Torque is transmitted by bolts through the cover plate in this case. Models GFR and GFRN are identical, except that model GFRN has a keyseat on the outside diameter to transmit torque.

Two paper seals are shipped with each unit to be placed between the outer race and cover plates.

This clutch is designed for oil lubrication. For grease lubrication, reduce the maximum overrunning speed to 50% of listed value.

For bolt tightening torque values, see page 134.

#### For Indexing Applications:

Maximum number indexes per minute is 350.

#### Specifications

Size	Torque Capacity lb.ft. (Nm)	Overrunning Speed Max. RPM		Shipping Weight lb. (kg)
		Inner Race	Outer Race	
12	41 (55)	4,000	5,600	1.1 (0.5)
15	92 (125)	3,600	5,200	1.76 (0.8)
20	134 (181)	2,700	4,600	2.21 (1)
25	213 (288)	2,100	3,600	3.31 (1.5)
30	369 (500)	1,700	3,200	4.85 (2.2)
35	535 (725)	1,550	3,000	6.62 (3)
40	756 (1025)	1,150	2,600	10.14 (4.6)
45	830 (1125)	1,000	2,400	10.36 (4.7)
50	1,568 (2125)	800	2,150	15.88 (7.2)
55	1,937 (2625)	750	2,000	18.96 (8.6)
60	2,583 (3500)	650	1,900	23.15 (10.5)
70	4,244 (5750)	550	1,750	29.77 (13.5)
80	6,273 (8500)	500	1,600	40.13 (18.2)
90	10,701 (14500)	450	1,450	62.84 (28.5)
100	14,760 (20000)	350	1,250	93.71 (42.5)
130	23,063 (31250)	250	1,000	143.33 (65)
150	51,660 (70000)	200	800	304.29 (138)

Note: Keyway to DIN 6885.1

# Modular “Building Block” Clutches

GFR/GFRN

GFR

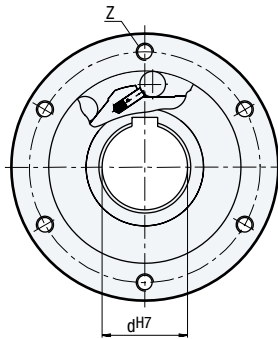
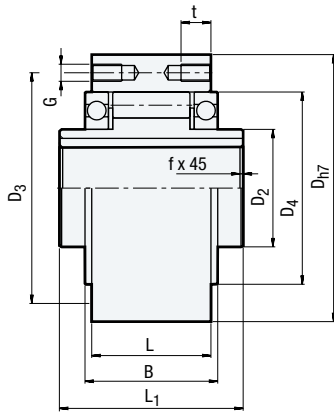

GFRN

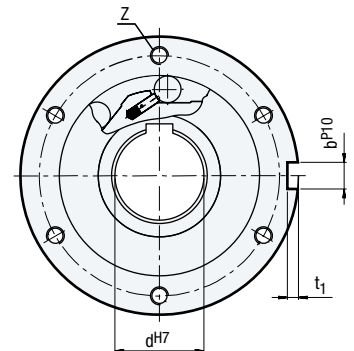
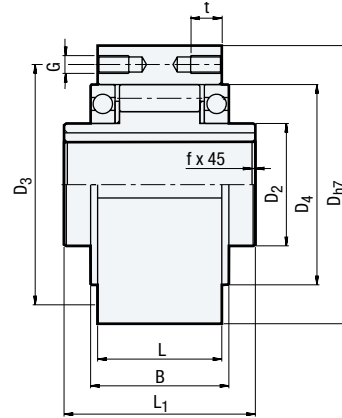

## Dimensions inches (mm)

Size	d <sup>H7</sup>	D <sub>h7</sub>	D <sub>2</sub>	D <sub>4</sub>	D <sub>3</sub>	t	L <sub>1</sub>	L	B	t <sub>1</sub>	b <sup>P10</sup>	f	G	Z
12	0.47 (12)	2.44 (62)	0.79 (20)	1.65 (42)	2.01 (51)	— (—)	1.65 (42)	0.79 (20)	1.06 (27)	0.10 (2.5)	0.16 (4)	1.10 (0.5)	(5.5)	2
15	0.59 (15)	2.68 (68)	0.98 (25)	1.85 (47)	2.20 (56)	0.31 (8)	2.05 (52)	1.10 (28)	1.26 (32)	0.12 (3)	0.20 (5)	0.03 (0.8)	M5	3
20	0.79 (20)	2.95 (75)	1.18 (30)	2.17 (55)	2.52 (64)	0.31 (8)	2.24 (57)	1.34 (34)	1.54 (39)	0.14 (3.5)	0.24 (6)	0.03 (0.8)	M5	3
25	0.98 (25)	3.54 (90)	1.57 (40)	2.68 (68)	3.07 (78)	0.39 (10)	2.36 (60)	1.38 (35)	1.57 (40)	0.16 (4)	0.31 (8)	0.04 (1)	M6	4
30	1.18 (30)	3.94 (100)	1.77 (45)	2.95 (75)	3.43 (87)	0.39 (10)	2.68 (68)	1.69 (43)	1.89 (48)	0.16 (4)	0.31 (8)	0.04 (1)	M6	4
35	1.38 (35)	4.33 (110)	1.97 (50)	3.15 (80)	3.78 (96)	0.47 (12)	2.91 (74)	1.77 (45)	2.01 (51)	0.20 (5)	0.39 (10)	0.04 (1)	M6	6
40	1.57 (40)	4.92 (125)	2.17 (55)	3.54 (90)	4.25 (108)	0.55 (14)	3.39 (86)	2.09 (53)	2.32 (59)	0.20 (5)	0.47 (12)	0.06 (1.5)	M8	6
45	1.77 (45)	5.12 (130)	2.36 (60)	3.74 (95)	4.41 (112)	0.55 (14)	3.39 (86)	2.09 (53)	2.32 (59)	0.22 (5.5)	0.55 (14)	0.06 (1.5)	M8	6
50	1.97 (50)	5.91 (150)	2.76 (70)	4.33 (110)	5.20 (132)	0.55 (14)	3.70 (94)	2.52 (64)	2.83 (72)	0.22 (5.5)	0.55 (14)	0.06 (1.5)	M8	8
55	2.17 (55)	6.30 (160)	2.95 (75)	4.53 (115)	5.43 (138)	0.63 (16)	4.09 (104)	2.60 (66)	2.83 (72)	0.24 (6)	0.63 (16)	0.08 (2)	M10	8
60	2.36 (60)	6.69 (170)	3.15 (80)	4.92 (125)	5.91 (150)	0.63 (16)	4.49 (114)	3.07 (78)	3.50 (89)	0.28 (7)	0.71 (18)	0.08 (2)	M10	10
70	2.76 (70)	7.48 (190)	3.54 (90)	5.51 (140)	6.50 (165)	0.63 (16)	5.28 (134)	3.74 (95)	4.25 (108)	0.30 (7.5)	0.79 (20)	0.10 (2.5)	M10	10
80	3.15 (80)	8.27 (210)	4.13 (105)	6.30 (160)	7.28 (185)	0.63 (16)	5.67 (144)	3.94 (100)	4.25 (108)	0.35 (9)	0.87 (22)	0.10 (2.5)	M10	10
90	3.54 (90)	9.06 (230)	4.72 (120)	7.09 (180)	8.11 (206)	0.79 (20)	6.22 (158)	4.53 (115)	4.92 (125)	0.35 (9)	0.98 (25)	0.12 (3)	M12	10
100	3.94 (100)	10.63 (270)	5.51 (140)	8.27 (210)	9.45 (240)	0.94 (24)	7.17 (182)	4.72 (120)	5.16 (131)	0.39 (10)	1.10 (28)	0.12 (3)	M16	10
130	4.72 (120)	12.20 (310)	6.30 (160)	9.45 (240)	10.94 (278)	0.94 (24)	8.35 (212)	5.98 (152)	6.61 (168)	0.43 (11)	32 (1.26)	0.12 (3)	M16	12
150	5.91 (150)	15.75 (400)	7.87 (200)	12.20 (310)	14.17 (360)	1.26 (32)	9.69 (246)	7.09 (180)	7.64 (194)	0.47 (12)	1.42 (36)	0.16 (4)	M20	12

Note: GFR 12 has through holes in outer race.

## Bore sizes and keyseats inches (mm)

Size	d <sup>H7</sup> Bore Size	Keyseat*
12	0.47 (12)	(4 X 1.8)
15	0.59 (15)	(5 X 2.3)
20	0.79 (20)	(6 X 2.8)
25	0.98 (25)	(8 X 3.3)
30	1.18 (30)	(8 X 3.3)
35	1.38 (35)	(10 X 3.3)
40	1.57 (40)	(12 X 3.3)
45	1.77 (45)	(14 X 3.8)
50	1.97 (50)	(14 X 3.8)
55	2.17 (55)	(16 X 4.3)
60	2.36 (60)	(18 X 4.4)
70	2.76 (70)	(20 X 4.9)
80	3.15 (80)	(22 X 5.4)
90	3.54 (90)	(25 X 5.4)
100	3.94 (100)	(28 X 6.4)
130	5.12 (130)	(32 X 7.4)
150	5.91 (150)	(36 X 8.4)

\* For keyseat sizes see DIN 6885.1 table on page 129.

# Modular “Building Block” Clutches

## GFR..F1F2, GFR..F2F7, GFRN..F5F6

Overrunning, Indexing Ball Bearing Supported, Ramp & Roller Clutches

### GFR..F1F2

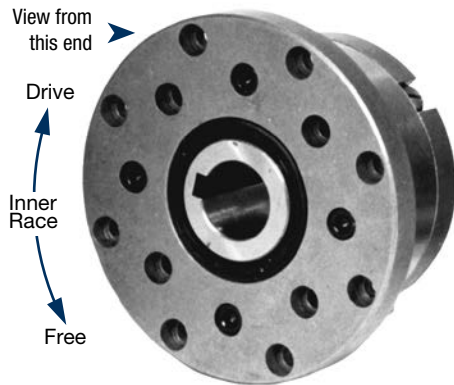

### GFRN..F5F6



Right Hand rotation shown.  
(Left Hand opposite.)

Specify direction of rotation when ordering.

Models GFR..F1F2/F2F7 and GFRN..F5F6 are ramp & roller type clutches, self-contained, sealed and bearing supported, using two 160 Series bearings.

They use the GFR and GFRN base modules described on previous pages.

Units must be oil lubricated before use if they are shipped unassembled.

Primarily used as an overrunning or indexing clutches. The cover combination is selected according to the type of drive, attachments required.

F2 and F6 covers are used to enclose the unit. They are equipped with 3 screws for oil filling, drain and level.

This design uses standard lip seals.

Covers may be easily assembled by the user, allowing for easily changing the rotation.

Alternatively, units can be shipped assembled and lubricated.

#### For Indexing Applications:

Maximum number indexes per minute is 350.

This clutch is designed for oil lubrication. For grease lubrication, reduce the maximum overrunning speed to 50% of listed value.

### Specifications

Size	Torque Capacity lb.ft. (Nm)	Overrunning Speed Max. RPM		Shipping Weight lb. (kg)
		Inner Race	Outer Race	
12	41 (55)	3,100	4,700	2.65 (1.2)
15	92 (125)	2,800	4,400	3.53 (1.6)
20	134 (181)	2,400	4,100	4.19 (1.9)
25	213 (288)	1,600	3,800	6.39 (2.9)
30	369 (500)	1,300	2,800	8.60 (3.9)
35	535 (725)	1,200	2,600	10.80 (4.9)
40	756 (1025)	850	2,300	16.54 (7.5)
45	830 (1125)	740	2,200	17.20 (7.8)
50	1,568 (2125)	580	1,950	23.81 (10.8)
55	1,937 (2625)	550	1,800	30.87 (14)
60	2,583 (3500)	530	1,700	37.04 (16.8)
70	4,244 (5750)	500	1,600	45.86 (20.8)
80	6,273 (8500)	480	1,500	59.54 (27)
90	10,701 (14500)	450	1,300	88.20 (40)
100	14,760 (20000)	350	1,100	147.74 (67)
130	23,063 (31250)	250	900	207.27 (94)
150	51,660 (70000)	200	700	412.34 (187)

**Note:** When ordering, please specify direction of rotation.

# Modular "Building Block" Clutches

## GFR..F1F2, GFR..F2F7, GFRN..F5F6

### GFR..F1F2

View from this end

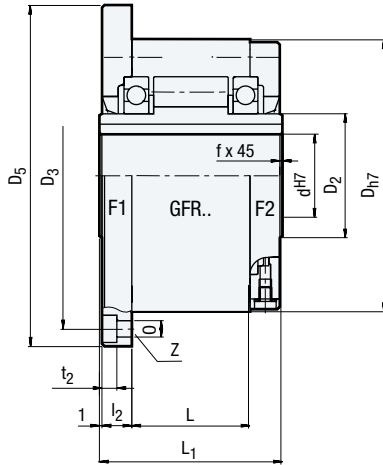

### GFR..F2F7

View from this end

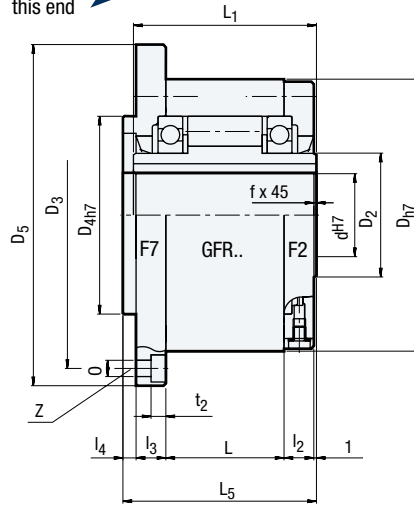

### GFRN..F5F6

View from this end

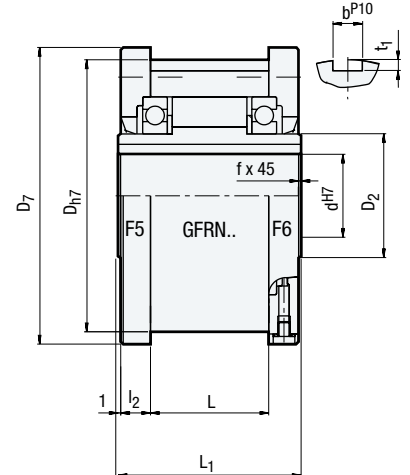

### Dimensions inches (mm)

Size	d <sup>h7</sup>	D <sub>h7</sub>	D <sub>5</sub>	D <sub>7</sub>	D <sub>3</sub>	D <sub>4h7</sub>	0	t <sub>2</sub>	L <sub>1</sub>	L <sub>5</sub>	L	l <sub>2</sub>	l <sub>3</sub>	l <sub>4</sub>	t <sub>1</sub>	b <sup>P10</sup>	f	z
12	0.47 (12)	2.44 (62)	3.35 (85)	2.76 (70)	2.83 (72)	1.65 (42)	0.22 (5.5)	0.22 (5.7)	1.65 (42)	1.73 (44)	0.79 (20)	0.39 (10)	0.39 (10)	0.12 (3)	0.10 (2.5)	0.16 (4)	0.02 (0.5)	2
15	0.59 (15)	2.68 (68)	3.62 (92)	2.99 (76)	3.07 (78)	1.85 (47)	0.22 (5.5)	0.22 (5.7)	2.05 (52)	2.13 (54)	1.10 (28)	0.43 (11)	0.43 (11)	0.12 (3)	0.12 (3)	0.20 (5)	0.03 (0.8)	3
20	0.79 (20)	2.95 (75)	3.86 (98)	3.31 (84)	3.35 (85)	2.17 (55)	0.22 (5.5)	0.22 (5.7)	2.24 (57)	2.32 (59)	1.34 (34)	0.41 (10.5)	0.41 (10.5)	0.12 (3)	0.14 (3.5)	0.24 (6)	0.03 (0.8)	3
25	0.98 (25)	3.54 (90)	4.65 (118)	3.90 (99)	4.09 (104)	2.68 (68)	0.26 (6.6)	0.27 (6.8)	2.36 (60)	2.44 (62)	1.38 (35)	0.45 (11.5)	0.45 (11.5)	0.12 (3)	0.16 (4)	0.31 (8)	0.04 (1)	4
30	1.18 (30)	3.94 (100)	5.04 (128)	4.29 (109)	4.49 (114)	2.95 (75)	0.26 (6.6)	0.27 (6.8)	2.68 (68)	2.76 (70)	1.69 (43)	0.45 (11.5)	0.45 (11.5)	0.12 (3)	0.16 (4)	0.31 (8)	0.04 (1)	4
35	1.38 (35)	4.33 (110)	5.51 (140)	4.69 (119)	4.88 (124)	3.15 (80)	0.26 (6.6)	0.27 (6.8)	2.91 (74)	2.99 (76)	1.77 (45)	0.53 (13.5)	0.51 (13)	0.14 (3.5)	0.20 (5)	0.39 (10)	0.04 (1)	6
40	1.57 (40)	4.92 (125)	6.30 (160)	5.31 (135)	5.59 (142)	3.54 (90)	0.35 (9)	0.35 (9)	3.39 (86)	3.46 (88)	2.09 (53)	0.61 (15.5)	0.59 (15)	0.14 (3.5)	0.20 (5)	0.47 (12)	0.06 (1.5)	6
45	1.77 (45)	5.12 (130)	6.50 (165)	5.51 (140)	5.75 (146)	3.74 (95)	0.35 (9)	0.35 (9)	3.39 (86)	3.46 (88)	2.09 (53)	0.61 (15.5)	0.59 (15)	0.14 (3.5)	0.22 (5.5)	0.55 (14)	0.06 (1.5)	6
50	1.97 (50)	5.91 (150)	7.28 (185)	6.30 (160)	6.54 (166)	4.33 (110)	0.35 (9)	0.35 (9)	3.70 (94)	3.78 (96)	2.52 (64)	0.55 (14)	0.51 (13)	0.16 (4)	0.22 (5.5)	0.55 (14)	0.06 (1.5)	8
55	2.17 (55)	6.30 (160)	8.03 (204)	6.69 (170)	7.17 (182)	4.53 (115)	0.43 (11)	0.43 (11)	4.09 (104)	4.17 (106)	2.60 (66)	0.71 (18)	0.67 (17)	0.16 (4)	0.24 (6)	0.63 (16)	0.08 (2)	8
60	2.36 (60)	6.69 (170)	8.43 (214)	7.17 (182)	7.56 (192)	4.92 (125)	0.43 (11)	0.43 (11)	4.49 (114)	4.57 (116)	3.07 (78)	0.67 (17)	0.63 (16)	0.16 (4)	0.28 (7)	0.71 (18)	0.08 (2)	10
70	2.76 (70)	7.48 (190)	9.21 (234)	7.95 (202)	8.35 (212)	5.51 (140)	0.43 (11)	0.43 (11)	5.28 (134)	5.35 (136)	3.74 (95)	0.73 (18.5)	0.69 (17.5)	0.16 (4)	0.30 (7.5)	0.79 (20)	0.10 (2.5)	10
80	3.15 (80)	8.27 (210)	10.00 (254)	8.74 (222)	9.13 (232)	6.30 (160)	0.43 (11)	0.43 (11)	5.67 (144)	5.75 (146)	3.94 (100)	0.83 (21)	0.79 (20)	0.16 (4)	0.35 (9)	0.87 (22)	0.10 (2.5)	10
90	3.54 (90)	9.06 (230)	10.94 (278)	9.53 (242)	10.00 (254)	7.09 (180)	0.55 (14)	0.51 (13)	6.22 (158)	6.30 (160)	4.53 (115)	0.81 (20.5)	0.75 (19)	0.18 (4.5)	0.35 (9)	0.98 (25)	0.12 (3)	10
100	3.94 (100)	10.63 (270)	13.19 (335)	11.10 (282)	12.01 (305)	8.27 (210)	0.71 (18)	0.69 (17.5)	7.17 (182)	7.24 (184)	4.72 (120)	1.18 (30)	1.10 (28)	0.20 (5)	0.39 (10)	1.10 (28)	0.12 (3)	10
130	5.12 (130)	12.20 (310)	14.96 (380)	12.68 (322)	13.58 (345)	9.45 (240)	0.71 (18)	0.69 (17.5)	8.35 (212)	8.43 (214)	5.98 (152)	1.14 (29)	1.06 (27)	0.20 (5)	0.43 (11)	1.26 (32)	0.12 (3)	12
150	5.91 (150)	15.75 (400)	19.09 (485)	16.22 (412)	17.52 (445)	12.20 (310)	0.87 (22)	0.85 (21.5)	9.69 (246)	9.76 (248)	7.09 (180)	1.26 (32)	1.18 (30)	0.20 (5)	0.47 (12)	1.42 (36)	0.16 (4)	12

Note: For bore and keyseat information see page 99.

Dimension D<sub>2</sub> listed on page 101.

# Modular “Building Block” Clutches

## GFR..F2F3, GFR..F3F4

### Backstopping Ball Bearing Supported, Ramp & Roller Clutches

GFR..F2F3

GFR..F3F4



Models GFR..F2F3/F3F4 are ramp & roller type clutches, self contained, sealed and bearing supported, using two 160 Series bearings.

They use the GFR base module. Units must be oil lubricated before use if they are shipped disassembled and, in any case, for the F3F4 combination.

These cover combinations are primarily used as backstops.

The F3 cover acts as a torque arm and has an integrated restraining bolt. The restraining bolt should go into a slot in a fixed part of the machine. The restraining bolt must have a radial clearance of 1% of the bolt’s diameter. The torque arm and bearings must not be rigidly mounted.

F2 and F4 covers are used to enclose the unit. They are equipped with 3 screws for oil filling, drain and level.

If using cover type F4, the shaft end plate and its screw must be sealed to avoid oil leakage through the keyway.

Covers are easily removed, allowing for on site selection of rotation direction.

If requested, units can be shipped assembled and lubricated for the F2F3 combination.

#### For Indexing Applications:

Maximum number indexes per minute is 350.

This clutch is designed for oil lubrication. For grease lubrication, reduce the maximum overrunning speed to 50% of listed value.

### Specifications

Size	Torque Capacity lb.ft. (Nm)	Overrunning Speed	Shipping Weight lb. (kg)
		Max. RPM Inner Race	
12	41 (55)	3,100	3.09 (1.4)
15	92 (125)	2,800	3.97 (1.8)
20	134 (181)	2,400	5.07 (2.3)
25	213 (288)	1,600	7.50 (3.4)
30	369 (500)	1,300	9.92 (4.5)
35	535 (725)	1,200	12.35 (5.6)
40	756 (1025)	850	18.74 (8.5)
45	830 (1125)	740	19.62 (8.9)
50	1,568 (2125)	580	28.22 (12.8)
55	1,937 (2625)	550	35.72 (16.2)
60	2,583 (3500)	530	42.56 (19.3)
70	4,244 (5750)	500	51.82 (23.5)
80	6,273 (8500)	480	70.56 (32)
90	10,701 (14500)	450	104.08 (47.2)
100	14,760 (20000)	350	167.58 (76)
130	23,063 (31250)	250	242.55 (110)
150	51,660 (70000)	200	471.87 (214)

**Note:** When ordering, please specify direction of rotation.



# Modular “Building Block” Clutches

## GFR..F2F3, GFR..F3F4

### GFR..F2F3

View from  
this end

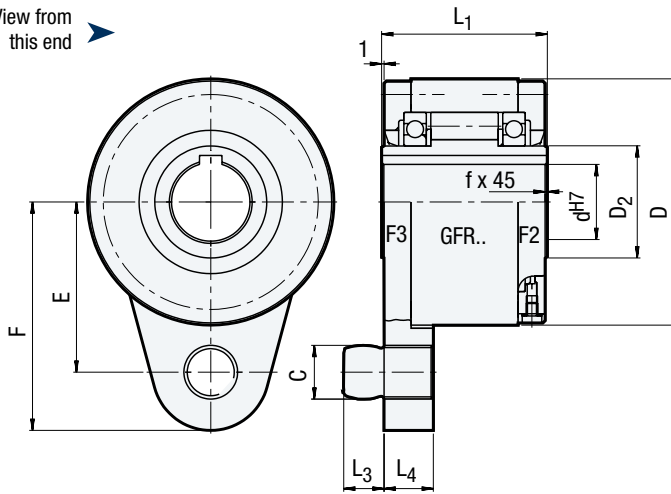

### GFR..F3F4

View from  
this end

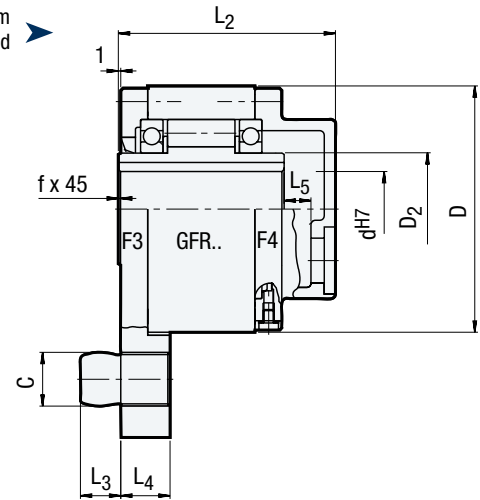

### Dimensions inches (mm)

Size	d <sup>H7</sup>	D	D <sub>2</sub>	C	L <sub>1</sub>	L <sub>2</sub>	L <sub>3</sub>	L <sub>4</sub>	F	E	L <sub>5</sub>	f
12	0.47 (12)	2.44 (62)	0.79 (20)	0.39 (10)	1.65 (42)	2.52 (64)	0.39 (10)	0.51 (13)	2.32 (59)	1.73 (44)	0.24 (6)	0.02 (0.5)
15	0.59 (15)	2.68 (68)	0.98 (25)	0.39 (10)	2.05 (52)	3.07 (78)	0.39 (10)	0.51 (13)	2.44 (62)	1.85 (47)	0.39 (10)	0.03 (0.8)
20	0.79 (20)	2.95 (75)	1.18 (30)	0.47 (12)	2.24 (57)	3.23 (82)	0.43 (11)	0.59 (15)	2.83 (72)	2.13 (54)	0.39 (10)	0.03 (0.8)
25	0.98 (25)	3.54 (90)	1.57 (40)	0.63 (16)	2.36 (60)	3.35 (85)	0.55 (14)	0.71 (18)	3.31 (84)	2.44 (62)	0.39 (10)	0.04 (1)
30	1.18 (30)	3.94 (100)	1.77 (45)	0.63 (16)	2.68 (68)	3.74 (95)	0.55 (14)	0.71 (18)	3.62 (92)	2.68 (68)	0.39 (10)	0.04 (1)
35	1.38 (35)	4.33 (110)	1.97 (50)	0.79 (20)	2.91 (74)	4.02 (102)	0.71 (18)	0.98 (25)	4.02 (102)	2.99 (76)	0.47 (12)	0.04 (1)
40	1.57 (40)	4.92 (125)	2.17 (55)	0.79 (20)	3.39 (86)	4.53 (115)	0.71 (18)	0.98 (25)	4.41 (112)	3.35 (85)	0.47 (12)	0.06 (1.5)
45	1.77 (45)	5.12 (130)	2.36 (60)	0.98 (25)	3.39 (86)	4.53 (115)	0.87 (22)	0.98 (25)	4.72 (120)	3.54 (90)	0.47 (12)	0.06 (1.5)
50	1.97 (50)	5.91 (150)	2.76 (70)	0.98 (25)	3.70 (94)	4.84 (123)	0.87 (22)	0.98 (25)	5.31 (135)	4.02 (102)	0.47 (12)	0.06 (1.5)
55	2.17 (55)	6.30 (160)	2.95 (75)	1.26 (32)	4.09 (104)	5.43 (138)	0.98 (25)	1.18 (30)	5.59 (142)	4.25 (108)	0.59 (15)	0.08 (2)
60	2.36 (60)	6.69 (170)	3.15 (80)	1.26 (32)	4.49 (114)	5.79 (147)	0.98 (25)	1.18 (30)	5.71 (145)	4.41 (112)	0.59 (15)	0.08 (2)
70	2.76 (70)	7.48 (190)	3.54 (90)	1.50 (38)	5.28 (134)	6.61 (168)	1.18 (30)	1.38 (35)	6.89 (175)	5.31 (135)	0.63 (16)	0.10 (2.5)
80	3.15 (80)	8.27 (210)	4.13 (105)	1.50 (38)	5.67 (144)	7.01 (178)	1.18 (30)	1.38 (35)	7.28 (185)	5.71 (145)	0.63 (16)	0.10 (2.5)
90	3.54 (90)	9.06 (230)	4.72 (120)	1.97 (50)	6.22 (158)	7.56 (192)	1.57 (40)	1.77 (45)	8.07 (205)	6.10 (155)	0.63 (16)	0.12 (3)
100	3.94 (100)	10.63 (270)	5.51 (140)	1.97 (50)	7.17 (182)	8.54 (217)	1.57 (40)	1.77 (45)	9.06 (230)	7.09 (180)	0.63 (16)	0.12 (3)
130	5.12 (130)	12.20 (310)	6.30 (160)	2.68 (68)	8.35 (212)	9.84 (250)	2.17 (55)	2.36 (60)	10.55 (268)	8.07 (205)	0.71 (18)	0.12 (3)
150	5.91 (150)	15.75 (400)	7.87 (200)	2.68 (68)	9.69 (246)	11.26 (286)	2.17 (55)	2.36 (60)	12.80 (325)	10.04 (255)	0.79 (20)	0.16 (4)

Note: For bore and keyseat information see page 99.

# Modular “Building Block” Clutches

## RIZ/RINZ

### Overrunning, Backstopping Ball Bearing Supported, Centrifugal Throwout (C/T) Sprag Clutches

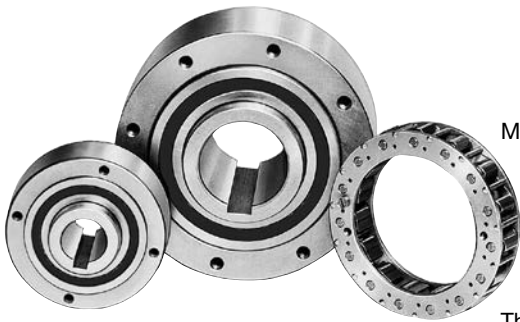

Models RIZ and RINZ are centrifugal throw-out sprag type clutches with the inner race rotating. Suitable for backstop, or overrunning clutch applications. Only the inner race is designed for overrunning.

These units are part of the Stieber modular system. They are bearing supported using Series 60 grease sealed bearings.

Units are shipped with grease and ready to install in either a horizontal or vertical position.

Models RIZ and RINZ are designed to be used with G series covers (see following pages). If the unit is to be installed inside a housing where oil lubrication is available, please specify type RIW and RIWN. To facilitate the oil flow the F series covers from model GFR and GFRN are then used without seals. Models

RIZ and RINZ are identical, except that model RINZ has a keyseat on the outside diameter to transmit torque.

For bolt tightening torque values, see page 134.

#### Maintenance

The Model RIZ using grease sealed bearings has almost zero lubrication maintenance requirements. The C/T Sprag feature provides no Sprag contact or wear during overrunning when operated above the Sprag lift-off speed. The typical recommended maintenance is to replace the bearing every three years. The Sprag assembly and race are to be relubricated with grease for corrosion protection at this time. All applications should be reviewed by Formsprag Engineering for complete Maintenance recommendation.

### Specifications

Size	Torque Capacity lb.ft. (Nm)	Overrunning Speed Max. RPM			Lubrication	Shipping Weight lb. (kg)
		Drive	Sprag Lift-off	Inner Race Overrunning		
30	276 (375)	350	780	9,000	Grease	5.07 (2.3)
35	406 (550)	320	740	8,500	Grease	7.06 (3.2)
40	590 (800)	315	720	7,500	Grease	10.58 (4.8)
45	673 (912)	285	665	6,600	Grease	11.03 (5)
50	1,033 (1400)	265	610	6,000	Grease	16.54 (7.5)
60	1,734 (2350)	200	490	5,300	Grease	28.00 (12.7)
70	2,250 (3050)	210	480	4,100	Grease	31.97 (14.5)
80	3,321 (4500)	190	450	3,600	Grease	41.90 (19)
90	4,132 (5600)	180	420	2,700	Grease	65.05 (29.5)
100	7,748 (10500)	200	455	2,700	Grease	93.71 (42.5)
130	11,623 (15750)	180	415	2,400	Grease	154.35 (70)

**Note:** When ordering, please specify direction of rotation.

# Modular “Building Block” Clutches

RIZ/RINZ

RIZ

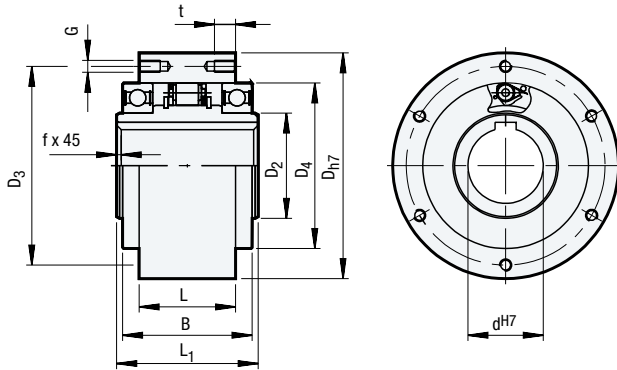

RINZ

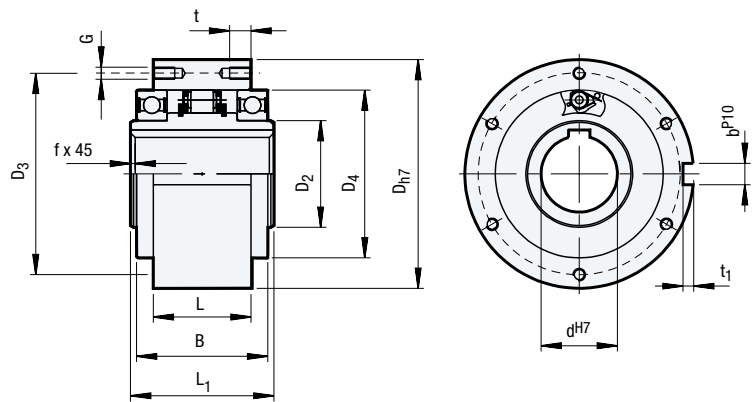

## Dimensions inches (mm)

Size	d <sup>H7</sup>	D <sub>n7</sub>	D <sub>2</sub>	D <sub>4</sub>	D <sub>3</sub>	G	Number of Holes	L <sub>1</sub>	L	B	t	f	t <sub>1</sub>	b <sup>P10</sup>
30	1.18 (30)	3.94 (100)	1.77 (45)	2.95 (75)	3.43 (87)	M6	6	2.68 (68)	1.69 (43)	2.38 (60.5)	0.39 (10)	0.04 (1)	0.16 (4)	0.31 (8)
35	1.38 (35)	4.33 (110)	1.97 (50)	3.15 (80)	3.78 (96)	M6	6	2.91 (74)	1.77 (45)	2.48 (63)	0.47 (12)	0.04 (1)	0.20 (5)	0.39 (10)
40	1.57 (40)	4.92 (125)	2.17 (55)	3.54 (90)	4.25 (108)	M8	6	3.39 (86)	2.09 (53)	2.87 (73)	0.55 (14)	0.06 (1.5)	0.20 (5)	0.47 (12)
45	1.77 (45)	5.12 (130)	2.36 (60)	3.74 (95)	4.41 (112)	M8	8	3.39 (86)	2.09 (53)	2.87 (73)	0.55 (14)	0.06 (1.5)	0.22 (5.5)	0.55 (14)
50	1.97 (50)	5.91 (150)	2.76 (70)	4.33 (110)	5.20 (132)	M8	8	3.70 (94)	2.52 (64)	3.39 (86)	0.55 (14)	0.06 (1.5)	0.22 (5.5)	0.55 (14)
60	2.36 (60)	6.69 (170)	3.15 (80)	4.92 (125)	5.91 (150)	M10	10	4.49 (114)	3.07 (78)	4.13 (105)	0.63 (16)	0.08 (2)	0.28 (7)	0.71 (18)
70	2.76 (70)	7.48 (190)	3.54 (90)	5.51 (140)	6.50 (165)	M10	10	5.28 (134)	3.74 (95)	4.88 (124)	0.63 (16)	0.10 (2.5)	0.30 (7.5)	0.79 (20)
80	3.15 (80)	8.27 (210)	4.13 (105)	6.30 (160)	7.28 (185)	M10	10	5.67 (144)	3.94 (100)	4.88 (124)	0.63 (16)	0.10 (2.5)	0.35 (9)	0.87 (22)
90	3.54 (90)	9.06 (230)	4.72 (120)	7.09 (180)	8.11 (206)	M12	10	6.22 (158)	4.53 (115)	5.63 (143)	0.79 (20)	0.12 (3)	0.35 (9)	0.98 (25)
100	3.94 (100)	10.63 (270)	5.51 (140)	8.27 (210)	9.45 (240)	M16	10	7.17 (182)	4.72 (120)	6.02 (153)	0.94 (24)	0.12 (3)	0.39 (10)	1.10 (28)
130	5.12 (130)	12.20 (310)	6.30 (160)	9.45 (240)	10.94 (278)	M16	12	8.35 (212)	5.98 (152)	7.64 (194)	0.94 (24)	0.12 (3)	0.43 (11)	1.26 (32)

## Bore sizes and keyseats

inches (mm)

Size	d <sup>H7</sup> Bore Size	Keyseat*
30	1.18 (30)	(8 X 3.3)
35	1.38 (35)	(10 X 3.3)
40	1.57 (40)	(12 X 3.3)
45	1.77 (45)	(14 X 3.8)
50	1.97 (50)	(14 X 3.8)
60	2.36 (60)	(18 X 4.4)
70	2.76 (70)	(20 X 4.9)
80	3.15 (80)	(22 X 5.4)
90	3.54 (90)	(25 X 5.4)
100	3.94 (100)	(28 X 6.4)
130	5.12 (130)	(32 X 7.4)

\* For keyseat sizes see DIN 6885.1 table on page 129.

# Modular “Building Block” Clutches

## RIZ, RINZ..G1G2, G2G7, G5G5

### Overrunning, Backstopping Ball Bearing Supported, Centrifugal Throwout (C/T) Sprag Clutches

Models RIZ..G1G2/G2G7, RINZ..G5G5 are centrifugal throw-out sprag type clutches with the inner race rotating. Only the inner race is designed for overrunning.

These are self-contained units designed for overrunning clutch applications. Typically used in creep drives, where the overrunning speed is high, but the drive speed is low, and does not exceed the maximum driving speed specified in the table.

Models RIZ and RINZ are equipped with G type covers featuring a grease pocket and contact-free seal.

When ordered complete, the unit is shipped grease lubricated, ready for either horizontal or vertical installation.

The Model RIZ using grease sealed bearings has almost zero lubrication maintenance requirements. The C/T Sprag feature provides no Sprag contact or wear during overrunning when operated above the Sprag lift-off speed. The typical recommended maintenance is to replace the bearing every three years. The Sprag assembly and race are to be relubricated with grease for corrosion protection at this time. All applications should be reviewed by Formsprag Engineering for complete Maintenance recommendation.

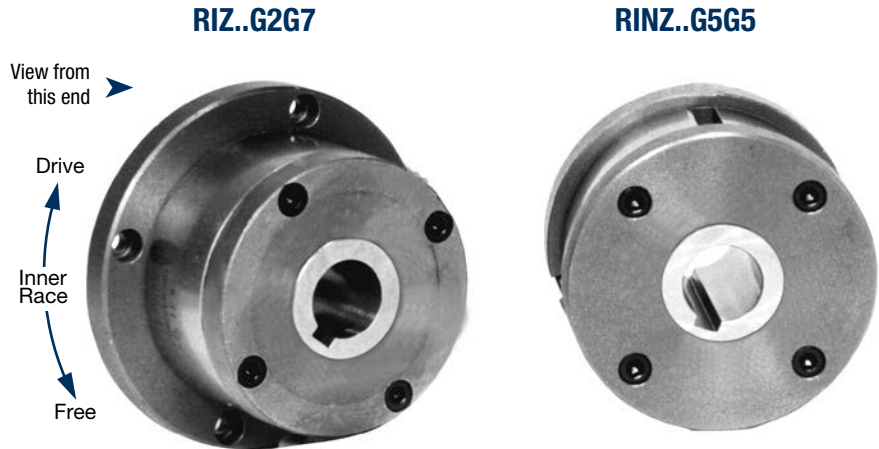

Right Hand rotation shown.  
(Left Hand opposite.)  
Specify direction of rotation when ordering.

### Specifications

Size	Torque Capacity lb.ft. (Nm)	Overrunning Speed Max. RPM			Lubrication	Shipping Weight lb. (kg)
		Max Drive	Sprag Lift-off	Inner Race Overrunning		
30	276 (375)	350	780	9,000	Grease	8.60 (3.9)
35	406 (550)	320	740	8,500	Grease	10.80 (4.9)
40	590 (800)	315	720	7,500	Grease	16.54 (7.5)
45	673 (912)	285	665	6,600	Grease	17.20 (7.8)
50	1,033 (1400)	265	610	6,000	Grease	23.81 (10.8)
60	1,734 (2350)	200	490	5,300	Grease	37.04 (16.8)
70	2,250 (3050)	210	480	4,100	Grease	45.86 (20.8)
80	3,321 (4500)	190	450	3,600	Grease	59.54 (27)
90	4,132 (5600)	180	420	2,700	Grease	88.20 (40)
100	7,748 (10500)	200	455	2,700	Grease	147.74 (67)
130	11,623 (15750)	180	415	2,400	Grease	207.27 (94)

**Note:** When ordering, please specify direction of rotation.

# Modular “Building Block” Clutches

RIZ, RINZ..G1G2, G2G7, G5G5

## RIZ..G1G2

View from this end

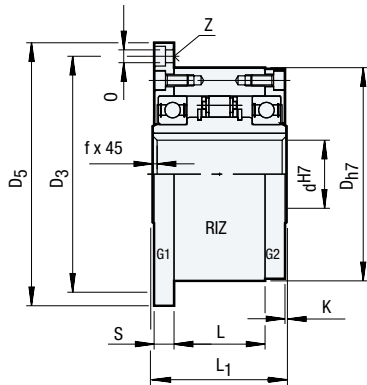

## RIZ..G2G7

View from this end

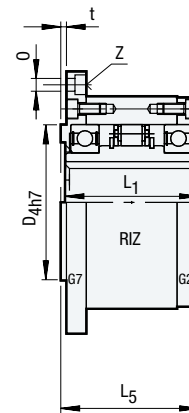

## RINZ..G5G5

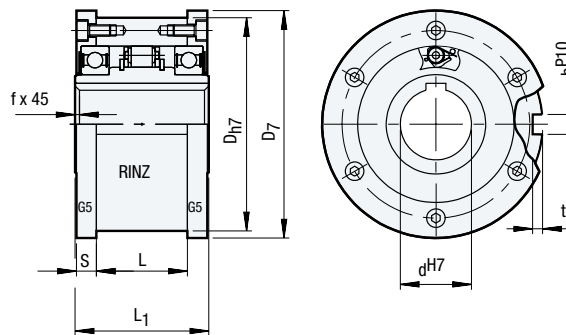

### Dimensions inches (mm)

Size	d <sup>H7</sup>	D <sub>h7</sub>	D <sub>3</sub>	D <sub>4h7</sub>	D <sub>5</sub>	D <sub>7</sub>	O	S	L <sub>1</sub>	L	L <sub>5</sub>	t	t <sub>1</sub>	b <sup>P10</sup>	f
30	1.18 (30)	3.94 (100)	4.49 (114)	2.95 (75)	5.04 (128)	4.29 (109)	0.26 (6.6)	0.45 (11.5)	2.68 (68)	1.69 (43)	2.76 (70)	0.12 (3)	0.16 (4)	0.31 (8)	0.04 (1)
35	1.38 (35)	4.33 (110)	4.88 (124)	3.15 (80)	5.51 (140)	4.69 (119)	0.26 (6.6)	0.53 (13.5)	2.91 (74)	1.77 (45)	2.99 (76)	0.14 (3.5)	0.20 (5)	0.39 (10)	0.04 (1)
40	1.57 (40)	4.92 (125)	5.59 (142)	3.54 (90)	6.30 (160)	5.31 (135)	0.35 (9)	0.61 (15.5)	3.39 (86)	2.09 (53)	3.46 (88)	0.14 (3.5)	0.20 (5)	0.47 (12)	0.06 (1.5)
45	1.77 (45)	5.12 (130)	5.75 (146)	3.74 (95)	6.50 (165)	5.51 (140)	0.35 (9)	0.61 (15.5)	3.39 (86)	2.09 (53)	3.46 (88)	0.14 (3.5)	0.22 (5.5)	0.55 (14)	0.06 (1.5)
50	1.97 (50)	5.91 (150)	6.54 (166)	4.33 (110)	7.28 (185)	6.30 (160)	0.35 (9)	0.55 (14)	3.70 (94)	2.52 (64)	3.78 (96)	0.16 (4)	0.22 (5.5)	0.55 (14)	0.06 (1.5)
60	2.36 (60)	6.69 (170)	7.56 (192)	4.92 (125)	8.43 (214)	7.17 (182)	0.43 (11)	0.67 (17)	4.49 (114)	3.07 (78)	4.57 (116)	0.16 (4)	0.28 (7)	0.71 (18)	0.08 (2)
70	2.76 (70)	7.48 (190)	8.35 (212)	5.51 (140)	9.21 (234)	7.95 (202)	0.43 (11)	0.73 (18.5)	5.28 (134)	3.74 (95)	5.35 (136)	0.16 (4)	0.30 (7.5)	0.79 (20)	0.10 (2.5)
80	3.15 (80)	8.27 (210)	9.13 (232)	6.30 (160)	10.00 (254)	8.74 (222)	0.43 (11)	0.83 (21)	5.67 (144)	3.94 (100)	5.75 (146)	0.16 (4)	0.35 (9)	0.87 (22)	0.10 (2.5)
90	3.54 (90)	9.06 (230)	10.00 (254)	7.09 (180)	10.94 (278)	9.53 (242)	0.55 (14)	0.81 (20.5)	6.22 (158)	4.53 (115)	6.30 (160)	0.18 (4.5)	0.35 (9)	0.98 (25)	0.12 (3)
100	3.94 (100)	10.63 (270)	12.01 (305)	8.27 (210)	13.19 (335)	11.10 (282)	0.71 (18)	1.18 (30)	7.17 (182)	4.72 (120)	7.24 (184)	0.20 (5)	0.39 (10)	1.10 (28)	0.12 (3)
130	5.12 (130)	12.20 (310)	13.58 (345)	9.45 (240)	14.96 (380)	12.68 (322)	0.71 (18)	1.14 (29)	8.35 (212)	5.98 (152)	8.43 (214)	0.20 (5)	0.43 (11)	1.26 (32)	0.12 (3)

Note: For bore and keyseat information see page 105.

# Modular “Building Block” Clutches

## RIZ..G2G3, G3G4

### Backstopping Ball Bearing Supported, Centrifugal Throw-out (C/T) Sprag Clutches



#### Backstop Applications

Models RIZ..G2G3/G3G4 are centrifugal throw-out sprag type clutches with the inner race rotating. Only the inner race is designed for overrunning.

They are self-contained units designed for backstop applications. The overrunning speed must not be less than the minimum specified in the table. This must be considered if using a variable speed drive.

The restraining bolt must be fitted into a slot on a fixed part of the machine. The radial clearance should be 1% of the bolt diameter. The torque arm and bearings must not be axially loaded.

Model RIZ is equipped with G type covers featuring grease pockets and contact-free seals.

When ordered complete, the unit is shipped grease lubricated, ready for either horizontal or vertical installation.

#### Specifications

Size	Torque Capacity lb.ft. (Nm)	Overrunning Speed Max. RPM			Lubrication	Shipping Weight lb. (kg)
		Max Drive	Sprag Lift-off	Inner Race Overrunning		
30	276 (375)	350	780	9,000	Grease	9.92 (4.5)
35	406 (550)	320	740	8,500	Grease	12.35 (5.6)
40	590 (800)	315	720	7,500	Grease	18.74 (8.5)
45	673 (912)	285	665	6,600	Grease	19.62 (8.9)
50	1,033 (1400)	265	610	6,000	Grease	28.22 (12.8)
60	1,734 (2350)	200	490	5,300	Grease	42.56 (19.3)
70	2,250 (3050)	210	480	4,100	Grease	51.82 (23.5)
80	3,321 (4500)	190	450	3,600	Grease	70.56 (32)
90	4,132 (5600)	180	420	2,700	Grease	104.08 (47.2)
100	7,748 (10500)	200	455	2,700	Grease	167.58 (76)
130	11,623 (15750)	180	415	2,400	Grease	242.55 (110)

**Note:** When ordering, please specify direction of rotation.

# Modular “Building Block” Clutches

## RIZ..G2G3, G3G4

### RIZ..G2G3

View from  
this end ➤

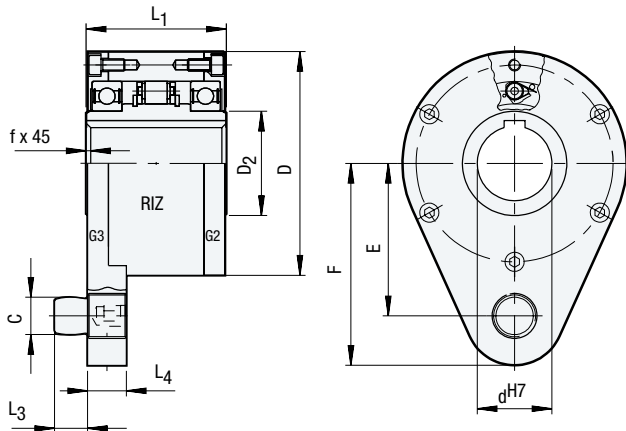

### RIZ..G3G4

View from  
this end ➤

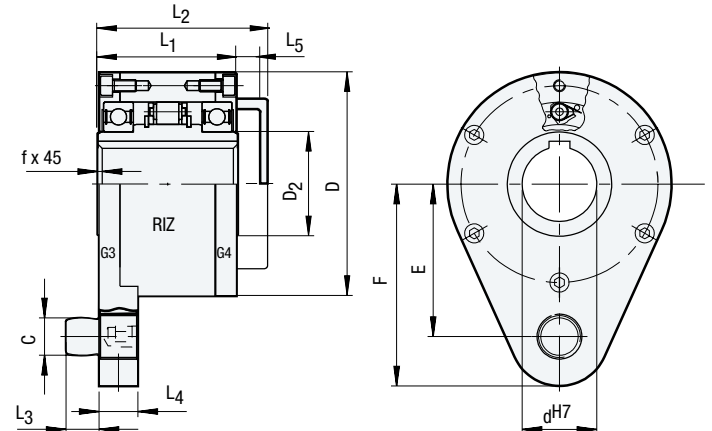

### Dimensions inches (mm)

Size	d <sup>H7</sup>	D	D <sub>2</sub>	C	L <sub>1</sub>	L <sub>2</sub>	L <sub>3</sub>	L <sub>4</sub>	F	E	L <sub>5</sub>	f
30	1.18 (30)	3.94 (100)	1.77 (45)	0.63 (16)	2.68 (68)	3.46 (88)	0.55 (14)	0.71 (18)	3.62 (92)	2.68 (68)	0.39 (10)	0.04 (1)
35	1.38 (35)	4.33 (110)	1.97 (50)	0.79 (20)	2.91 (74)	3.78 (96)	0.71 (18)	0.98 (25)	4.02 (102)	2.99 (76)	0.47 (12)	0.04 (1)
40	1.57 (40)	4.92 (125)	2.17 (55)	0.79 (20)	3.39 (86)	4.29 (109)	0.71 (18)	0.98 (25)	4.41 (112)	3.35 (85)	0.47 (12)	0.06 (1.5)
45	1.77 (45)	5.12 (130)	2.36 (60)	0.98 (25)	3.39 (86)	4.29 (109)	0.87 (22)	0.98 (25)	4.72 (120)	3.54 (90)	0.47 (12)	0.06 (1.5)
50	1.97 (50)	5.91 (150)	2.76 (70)	0.98 (25)	3.70 (94)	4.57 (116)	0.87 (22)	0.98 (25)	5.31 (135)	4.02 (102)	0.47 (12)	0.06 (1.5)
60	2.36 (60)	6.69 (170)	3.15 (80)	1.26 (32)	4.49 (114)	5.47 (139)	0.98 (25)	1.18 (30)	5.71 (145)	4.41 (112)	0.59 (15)	0.08 (2)
70	2.76 (70)	7.48 (190)	3.54 (90)	1.50 (38)	5.28 (134)	6.61 (168)	1.18 (30)	1.38 (35)	6.89 (175)	5.31 (135)	0.63 (16)	0.10 (2.5)
80	3.15 (80)	8.27 (210)	4.13 (105)	1.50 (38)	5.67 (144)	7.01 (178)	1.18 (30)	1.38 (35)	7.28 (185)	5.71 (145)	0.63 (16)	0.10 (2.5)
90	3.54 (90)	9.06 (230)	4.72 (120)	1.97 (50)	6.22 (158)	7.56 (192)	1.57 (40)	1.77 (45)	8.07 (205)	6.10 (155)	0.63 (16)	0.12 (3)
100	3.94 (100)	10.63 (270)	5.51 (140)	1.97 (50)	7.17 (182)	8.54 (217)	1.57 (40)	1.77 (45)	9.06 (230)	7.09 (180)	0.63 (16)	0.12 (3)
130	5.12 (130)	12.20 (310)	6.30 (160)	2.68 (68)	8.35 (212)	9.84 (250)	2.17 (55)	2.36 (60)	10.55 (268)	8.07 (205)	0.71 (18)	0.12 (3)

**Note:** For bore and keyseat information see page 105.

# Clutch Couplings

## AL..KEED2, ALM..KEED2

### Overrunning, Indexing, Backstopping Ball Bearing Supported, Ramp & Roller Clutch Couplings

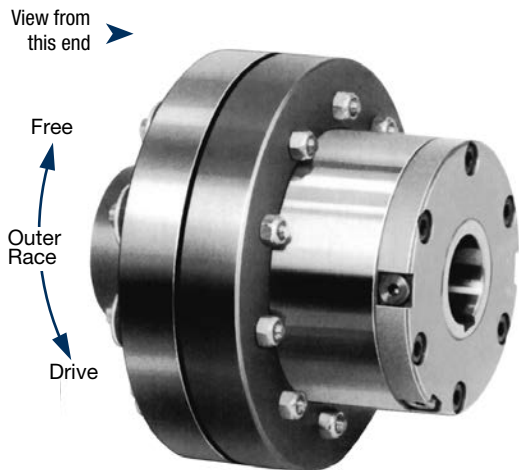

Right Hand rotation shown.  
(Left Hand opposite.)

Specify direction of rotation when ordering.

Model AL..KEED2 is a ramp & roller type clutch coupling, self contained, sealed and bearing supported, using two 160 Series bearings. Unit is shipped oil lubricated.

In this design, a standard AL clutch is connected to a KEE flexible coupling for in-line mounting. The KEE model is a rugged coupling, economical and suitable for many applications.

D2 cover is used to enclose the unit. It is equipped with two screws for oil filling.

We recommend that the unit be supplied assembled.

If grease lubrication is used, the maximum overrunning speed is reduced by 50%.

For bolt tightening torque values, see page 134.

#### Specifications

Model	Size	KEE Coupling	Torque Capacity lb.ft. (Nm)	Overrunning Speed Max. RPM		Hub Bore Range $d_K^{H7}$	Shipping Weight lb. (kg)
				Inner Race	Outer Race		
AL.. KEED2	12	2	41 (55)	2,500	6,000	0.47 – 0.98 (12 – 25)	6.62 (3)
	15	3	90 (122)	1,900	6,000	0.63 – 1.18 (16 – 30)	9.70 (4.4)
	20	3	90 (122)	1,600	5,600	0.63 – 1.18 (16 – 30)	10.14 (4.6)
	25	4	213 (288)	1,400	4,500	0.79 – 1.57 (20 – 40)	14.11 (6.4)
	30	5	369 (500)	1,300	4,100	0.79 – 1.97 (20 – 50)	24.26 (11)
	35	6	535 (725)	1,100	3,800	0.98 – 2.56 (25 – 65)	37.48 (17)
	40	6	756 (1025)	950	3,400	0.98 – 2.56 (25 – 65)	41.90 (19)
	45	6	775 (1050)	900	3,200	0.98 – 2.56 (25 – 65)	41.90 (19)
	50	7	1,292 (1750)	850	2,800	1.18 – 2.95 (30 – 75)	68.36 (31)
	55	8	1,937 (2625)	720	2,650	1.38 – 3.54 (35 – 90)	103.64 (47)
	60	8	2,030 (2750)	680	2,450	1.38 – 3.54 (35 – 90)	108.05 (49)
	70	10	4,244 (5750)	580	2,150	1.77 – 4.33 (45 – 110)	198.45 (90)
	80	11	6,273 (8500)	480	1,900	2.17 – 4.92 (55 – 125)	235.94 (107)
	90	12	10,148 (13750)	380	1,700	2.56 – 5.51 (65 – 140)	374.85 (170)
	100	14	14,760 (20000)	350	1,450	2.95 – 6.30 (75 – 160)	507.15 (230)
120	16	22,140 (30000)	250	1,250	3.35 – 7.09 (85 – 180)	727.65 (330)	
150	18	32,288 (43750)	180	980	3.74 – 7.87 (95 – 200)	1,102.50 (500)	
200	22	71,955 (97500)	120	750	4.92 – 9.84 (125 – 250)	2,127.83 (965)	
250	28	184,500 (250000)	100	620	6.30 – 12.60 (160 – 320)	3,803.62 (1725)	
ALM.. KEED2	25	4	213 (288)	1,100	2,800	0.79 – 1.57 (20 – 40)	14.11 (6.4)
	30	5	434 (588)	1,000	2,500	0.79 – 1.97 (20 – 50)	24.26 (11)
	35	6	618 (838)	900	2,400	0.98 – 2.56 (25 – 65)	37.48 (17)

**Note:** For clutch bore ( $d_K^{H7}$ ) and keyseat information see page 93. When ordering, please specify direction of rotation.



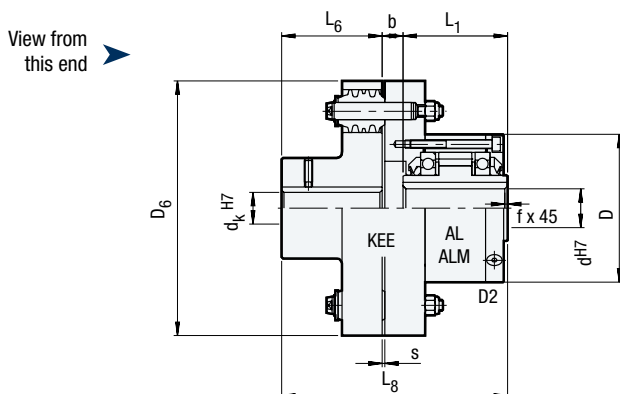

Dimensions inches (mm)

Model	Size	d <sup>H7</sup>	D	L <sub>1</sub>	D <sub>6</sub>	L <sub>6</sub>	L <sub>8</sub>	b	s	f
AL.. KEED2	12	0.47 (12)	2.44 (62)	1.65 (42)	3.82 (97)	1.38 (35)	3.54 (90)	0.51 (13)	0.12 (3)	0.02 (0.5)
	15	0.59 (15)	2.68 (68)	2.05 (52)	4.41 (112)	1.57 (40)	4.33 (110)	0.71 (18)	0.12 (3)	0.03 (0.8)
	20	0.79 (20)	2.95 (75)	2.24 (57)	4.41 (112)	1.57 (40)	4.51 (114.5)	0.69 (17.5)	0.12 (3)	0.03 (0.8)
	25	0.98 (25)	3.54 (90)	2.36 (60)	5.12 (130)	1.97 (50)	5.02 (127.5)	0.69 (17.5)	0.12 (3)	0.04 (1)
	30	1.18 (30)	3.94 (100)	2.68 (68)	6.30 (160)	2.36 (60)	5.83 (148)	0.79 (20)	0.08 (2)	0.04 (1)
	35	1.38 (35)	4.33 (110)	2.91 (74)	7.48 (190)	2.95 (75)	6.61 (168)	0.75 (19)	0.08 (2)	0.04 (1)
	40	1.57 (40)	4.92 (125)	3.39 (86)	7.48 (190)	2.95 (75)	7.01 (178)	0.67 (17)	0.08 (2)	0.06 (1.5)
	45	1.77 (45)	5.12 (130)	3.39 (86)	7.48 (190)	2.95 (75)	7.01 (178)	0.67 (17)	0.08 (2)	0.06 (1.5)
	50	1.97 (50)	5.91 (150)	3.62 (92)	8.86 (225)	3.54 (90)	8.15 (207)	0.98 (25)	0.10 (2.5)	0.06 (1.5)
	55	2.17 (55)	6.30 (160)	4.09 (104)	10.63 (270)	3.94 (100)	9.19 (233.5)	1.16 (29.5)	0.12 (3)	0.08 (2)
	60	2.36 (60)	6.69 (170)	4.49 (114)	10.63 (270)	3.94 (100)	9.61 (244)	1.18 (30)	0.12 (3)	0.08 (2)
	70	2.76 (70)	7.48 (190)	5.28 (134)	13.39 (340)	5.51 (140)	12.30 (312.5)	1.52 (38.5)	0.12 (3)	0.10 (2.5)
	80	3.15 (80)	8.27 (210)	5.67 (144)	14.96 (380)	6.30 (160)	13.39 (340)	1.42 (36)	0.12 (3)	0.10 (2.5)
	90	3.54 (90)	9.06 (230)	6.22 (158)	17.32 (440)	7.09 (180)	15.28 (388)	1.97 (50)	0.14 (3.5)	0.12 (3)
	100	3.94 (100)	10.63 (270)	7.17 (182)	19.69 (500)	7.87 (200)	16.63 (422.5)	1.59 (40.5)	0.14 (3.5)	0.12 (3)
	120	4.72 (120)	12.20 (310)	7.95 (202)	22.05 (560)	8.66 (220)	18.54 (471)	1.93 (49)	0.16 (4)	0.12 (3)
	150	5.91 (150)	15.75 (400)	9.69 (246)	25.20 (640)	9.84 (250)	21.38 (543)	1.85 (47)	0.16 (4)	0.16 (4)
	200	7.87 (200)	20.47 (520)	12.83 (326)	34.65 (880)	12.60 (320)	27.58 (700.5)	2.15 (54.5)	0.18 (4.5)	0.20 (5)
	250	9.84 (250)	24.02 (610)	15.59 (396)	45.67 (1160)	15.75 (400)	34.17 (868)	2.83 (72)	0.20 (5)	0.20 (5)
	ALM.. KEED2	25	0.98 (25)	3.54 (90)	2.36 (60)	5.12 (130)	1.97 (50)	5.02 (127.5)	0.69 (17.5)	0.12 (3)
30		1.18 (30)	3.94 (100)	2.68 (68)	6.30 (160)	2.36 (60)	5.83 (148)	0.79 (20)	0.08 (2)	0.04 (1)
35		1.38 (35)	4.33 (110)	2.91 (74)	7.48 (190)	2.95 (75)	6.61 (168)	0.75 (19)	0.08 (2)	0.04 (1)

# Clutch Couplings

## RIZ..ELG2

### Overrunning Ball Bearing Supported, Centrifugal Throw-out (C/T) Sprag Clutch Couplings

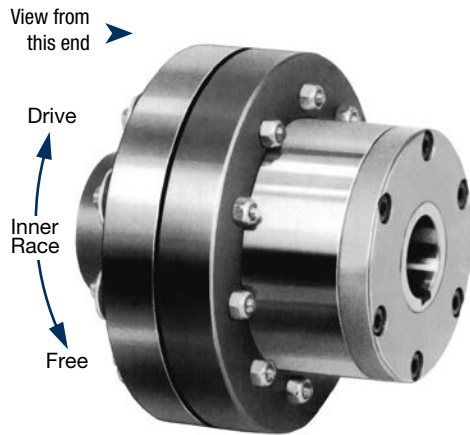

Model RIZ..ELG2 is a centrifugal throw-out sprag clutch with a coupling for in-line shaft mounting applications. In this design only the inner race can overrun.

They are self-contained units designed for overrunning clutch applications. Typically used in creep drives, where the overrunning speed is high, but the drive speed low, and does not exceed the maximum driving speed specified in the table.

When ordered complete, the unit is shipped grease lubricated, ready for either horizontal or vertical installation.

*Right Hand rotation shown.  
(Left Hand opposite.)*

*Specify direction of rotation when ordering.*

### Specifications

Size	EL	Torque Capacity lb.ft. (Nm)	Overrunning Speed Max. RPM			Lubrication	Shipping Weight lb. (kg)
			Drive	Sprag Lift-off	Overrunning		
30	5	231 (313)	350	780	9,000	Grease	24.26 (11)
35	6	277 (375)	320	740	8,500	Grease	37.48 (17)
40	6	576 (781)	315	720	7,500	Grease	41.90 (19)
45	6	660 (894)	285	665	6,600	Grease	41.90 (19)
50	7	1,033 (1400)	265	610	6,000	Grease	68.36 (31)
60	8	1,384 (1875)	200	490	5,300	Grease	108.05 (49)
70	10	2,077 (2815)	210	480	4,100	Grease	198.45 (90)
80	11	3,321 (4500)	190	450	3,600	Grease	235.94 (107)
90	12	4,244 (5750)	180	420	2,700	Grease	374.85 (170)
100	14	7,011 (9500)	200	455	2,700	Grease	507.15 (230)
130	16	12,454 (16875)	180	415	2,400	Grease	727.65 (330)

**Note:** When ordering, please specify direction of rotation.

### RIZ..ELG2

View from  
this end 

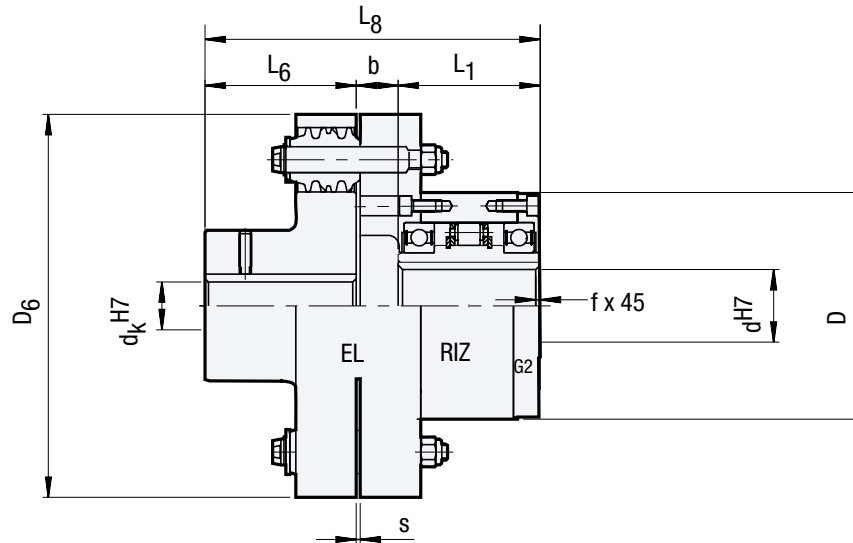

### Dimensions inches (mm)

Size	$d^{H7}$	$d_k^{H7}$ Bore Range	D	$L_1$	$D_6$	$L_6$	$L_8$	b	s	f
30	1.18 (30)	0.79 – 2.17 (20 – 55)	3.94 (100)	2.68 (68)	6.30 (160)	2.36 (60)	5.81 (147.5)	0.77 (19.5)	0.08 (2)	0.04 (1)
35	1.38 (35)	0.98 – 2.95 (25 – 75)	4.33 (110)	2.91 (74)	7.48 (190)	2.95 (75)	6.56 (166.5)	0.69 (17.5)	0.08 (2)	0.04 (1)
40	1.57 (40)	0.98 – 2.95 (25 – 75)	4.92 (125)	3.39 (86)	7.48 (190)	2.95 (75)	6.95 (176.5)	0.61 (15.5)	0.08 (2)	0.06 (1.5)
45	1.77 (45)	0.98 – 2.95 (25 – 75)	5.12 (130)	3.39 (86)	7.48 (190)	2.95 (75)	6.95 (176.5)	0.61 (15.5)	0.08 (2)	0.06 (1.5)
50	1.97 (50)	1.18 – 3.35 (30 – 85)	5.91 (150)	3.70 (94)	8.86 (225)	3.54 (90)	8.21 (208.5)	0.96 (24.5)	0.10 (2.5)	0.06 (1.5)
60	2.36 (60)	1.38 – 3.94 (35 – 100)	6.69 (170)	4.49 (114)	10.63 (270)	3.94 (100)	9.61 (244)	1.18 (30)	0.12 (3)	0.08 (2)
70	2.76 (70)	1.77 – 4.72 (45 – 120)	7.48 (190)	5.28 (134)	13.39 (340)	5.51 (140)	12.30 (312.5)	1.52 (38.5)	0.12 (3)	0.10 (2.5)
80	3.15 (80)	2.17 – 5.71 (55 – 145)	8.27 (210)	5.67 (144)	14.96 (380)	6.30 (160)	13.39 (340)	1.42 (36)	0.12 (3)	0.10 (2.5)
90	3.54 (90)	2.56 – 6.50 (65 – 165)	9.06 (230)	6.22 (158)	17.32 (440)	7.09 (180)	15.28 (388)	1.97 (50)	0.14 (3.5)	0.12 (3)
100	3.94 (100)	2.95 – 6.69 (75 – 170)	10.63 (270)	7.17 (182)	19.69 (500)	7.87 (200)	16.63 (422.5)	1.59 (40.5)	0.14 (3.5)	0.12 (3)
130	5.12 (130)	3.35 – 7.09 (85 – 180)	12.20 (310)	8.35 (212)	22.05 (560)	8.66 (220)	18.98 (482)	1.97 (50)	0.16 (4)	0.12 (3)

**Note:** For clutch bore and keyseat information see page 105.

# Clutch Couplings

## FW/FWW

### Overrunning Ball Bearing Supported, Sprag Clutch Couplings

#### FW Series



For in-line shaft applications

Outer race overrunning—  
intermediate speed

Inner race overrunning—  
high speed

FW clutch couplings are comprised of an FSO clutch with a disc coupling. The Model FSO clutch can not accommodate any misalignment, so a coupling is always required for shaft to shaft in-line mounting. The FW clutch couplings are designed for high speed inner race overrunning

and intermediate speed outer race overrunning. They are usually selected for inner race overrunning. Where outer race overrunning is necessary, use the AL.. KMSD2 clutch coupling.

FW clutch couplings accommodate angular and parallel misalignment, are torsionally stiff and can couple shafts of different sizes.

Increased clutch-coupling speeds are possible with FSO clutches having steel labyrinth grease seals.

C/T is ideal for applications with high speed outer race overrunning and slow drive speed.

Models 403 through 712 are equipped with PCE sprags and are shipped from the factory with Mobil DTE Heavy Medium Oil or Low-Temp Grease.

FW-752 through 812 clutches are shipped from the factory with Fiske Brothers AERO-Lubriplate Low-Temp Grease or Mobile DTE Heavy Medium Oil.

#### Typical Applications

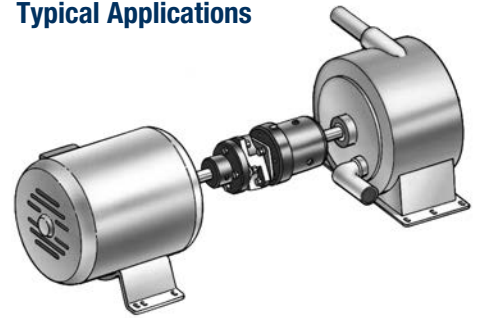

View from  
this end

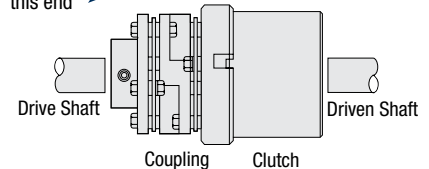

The FW Series clutch coupling is designed for **inner race overrunning**. Mount the clutch half of the unit on the driven shaft.

#### FWW Series



For in-line shaft applications  
requiring low torque

FWW clutch couplings are designed for applications where the torque requirement is low in comparison to the shaft diameters. Both bore diameters in coupling hubs are larger than clutch bores in FW and FWW series.

C/T sprags are available in FWW series.

Increased clutch-coupling speeds are possible with FSO clutches having steel labyrinth seals.

Check key and shaft stress before making final clutch or coupling selection since this may determine maximum allowable drive torque capacity.

FWW-420 through 640 clutches are shipped from the factory with Mobil DTE Heavy Medium oil or Fiske Brothers Low-Temp Lubriplate Grease.

The FWW Series clutch coupling is designed for **inner race overrunning**. Mount the drive coupling on the drive shaft and the driven coupling on the driven shaft.

**Note:** Mounting is reversed for C/T Series.

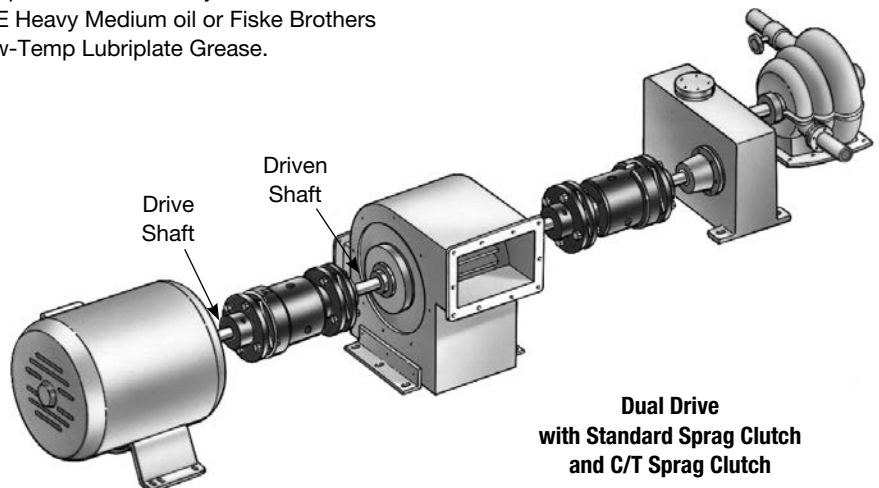

**Dual Drive  
with Standard Sprag Clutch  
and C/T Sprag Clutch**

### Turning Gear Drive with C/T Sprag Clutch

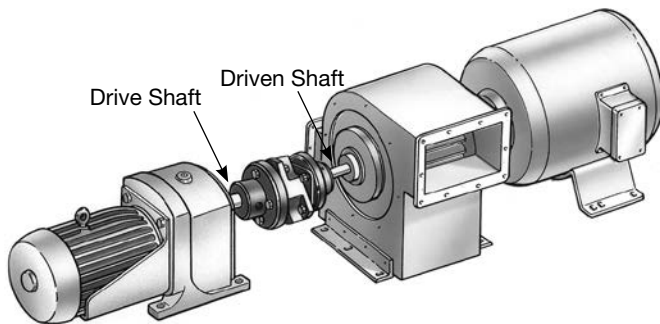

### With C/T Sprags

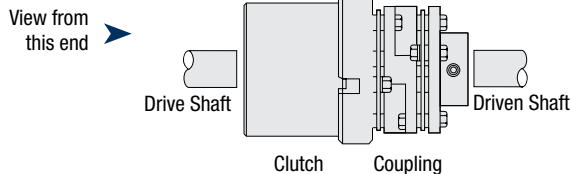

The model FW (C/T) clutch coupling is designed for outer race overrunning. Mount the clutch half of the unit on the drive shaft.

### FWW

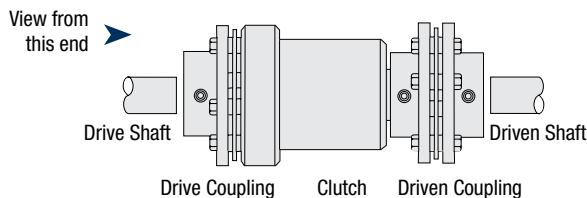

The model FWW clutch coupling is designed for inner race overrunning. Mount the drive coupling on the drive shaft and the driven coupling on the driven shaft.

### With C/T Sprags

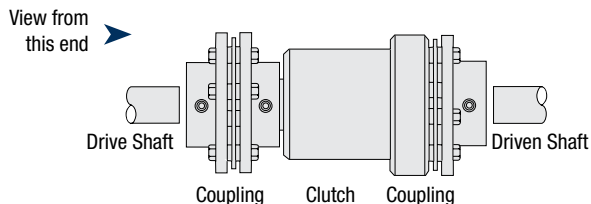

**Note:** Mounting is reversed for C/T Series.

### Bore and keyseat tolerances for couplings

Couplings will be bored to AGMA Standard 511.02 for Flexible Couplings. Bore fit normally supplied is listed to the right.

For tolerances not listed, please consult Formsprag.

### Standard bore tolerances inches (mm)

Nominal Shaft Dia.	Clearance Fit Class 1 Nominal	Interference Fit Nominal*
1/2" through 1 1/2" (12.7 through 38.1)	+ .001 / - .000 (+.025/- .000)	Less .001 + .0005 / - .000 (Less .025 + .013/- .000)
Over 1 1/2" through 2" (Over 38.1 through 50.8)	+ .001 / - .000 (+.025/- .000)	Less .002 + .001 / - .000 (Less .051 + .025/- .000)
Over 2" through 3" (Over 50.8 through 76.2)	+ .0015 / - .000 (+.038/- .000)	Less .003 + .0015 / - .000" (Less .076 + .038/- .000)
Over 3" through 4" (Over 76.2 through 101.6)	+ .0015 / - .000 (+.038/- .000)	Less .003 + .0015 / - .000" (Less .076 + .038/- .000)
Over 4" through 7" (Over 101.6 through 177.8)	+ .002 / - .000 (+.051/- .000)	Less .003 + .0015 / - .000" (Less .076 + .038/ .000)

\* Available at extra charge. Sizes are standard unless otherwise specified.

### Standard keyseats inches (mm)

Nominal Shaft Diameter		Keyseat	
Over	Through	Width + .002 / - .000 (+.051/- .00)	Length + .010 / - .000 (+.254/- .000)
3/8 (9.525)	7/16 (11.100)	3/32 (2.362)	1/16 (1.168)
7/16 (11.100)	9/16 (14.275)	1/8 (3.175)	1/16 (1.575)
9/16 (14.275)	7/8 (22.225)	3/16 (4.750)	3/32 (2.362)
7/8 (22.225)	1 1/4 (31.750)	1/4 (6.350)	1/8 (3.175)
1 1/4 (31.750)	1 3/8 (34.925)	5/16 (7.925)	5/32 (3.962)
1 3/8 (34.925)	1 3/4 (44.450)	3/8 (9.525)	3/16 (4.750)
1 3/4 (44.450)	2 1/4 (57.150)	1/2 (12.700)	1/4 (6.350)
2 1/4 (57.150)	2 3/4 (69.850)	5/8 (15.875)	5/16 (7.925)
2 3/4 (69.850)	3 1/4 (82.550)	3/4 (19.050)	3/8 (9.525)
3 1/4 (82.550)	3 3/4 (95.250)	7/8 (22.225)	7/16 (11.100)
3 3/4 (95.250)	4 1/2 (114.300)	1 (25.400)	1/2 (12.700)
4 1/2 (114.300)	5 1/2 (139.700)	1 1/4 (31.750)	5/8 (15.875)
5 1/2 (139.700)	7 (177.800)	1 1/2 (38.100)	3/4 (19.050)

# Clutch Couplings

## FW/FWW

### FW

#### Specifications

FW Size	Torque Capacity lb.ft. (Nm)	HP Rating/ 100 RPM HP (kw)	Maximum Overrunning Speed (RPM)								Clutch Size*	Coupling Size	Shipping Weight lb. (kg)
			Standard Sprag			C/T Sprag							
			Outer Race	Inner <sup>†</sup> Race	Drive Speed	Outer Race	Inner Race	Sprag Lift-off	Drive Speed				
403	65 (88)	1.2 (.90)	850	2,800	6,000	5,000	2,800	1,300	1,100	FSO-400	AP10W	11 (5)	
406	180 (244)	3.5 (2.6)	850	2,800	6,000	5,000	2,800	1,300	1,100	FSO-400	AP20W	13 (6)	
504	180 (244)	3.5 (2.6)	800	2,500	6,000	4,000	2,500	1,200	1,000	FSO-500	AP20W	19 (9)	
508	575 (778)	11.0 (8.2)	800	2,500	5,000	4,000	2,500	1,200	1,000	FSO-500	AP30W	29 (13)	
607	325 (440)	6.2 (4.6)	750	2,200	5,000	3,600	2,200	1,200	1,000	FSO-600	AP25W	31 (14)	
610	1503 (2033)	29.0 (21.6)	750	2,200	3,750	3,600	2,200	1,200	1,000	FSO-600	AP40W	54 (25)	
708	945 (1281)	18.0 (13.4)	450	1,600	3,000	2,500	1,600	1,000	800	FSO-700	AP35W	68 (31)	
712	2520 (3416)	48.0 (35.8)	450	1,600	3,000	2,500	1,600	1,000	800	FSO-700	AP45W	86 (30)	
752	2520 (3416)	48.0 (35.8)	650	1,000	3,000	1,800	1,000	800	650	FSO-750	AP45W	127 (58)	
812	2520 (3416)	48.0 (35.8)	525	850	3,000	1,500	850	675	525	FSO-800	AP45W	146 (66)	

\* For clutch dimensions and bore/keyseat sizes, see pages 15 and 17.

† Labyrinth grease seals permit higher inner race overrunning speed; see pages 14 and 16.

### FWW

#### Specifications

FWW Size	Torque Capacity lb.ft. (Nm)	HP Rating/ 100 RPM HP (kw)	Maximum RPM Overrunning Speed								Clutch Size*	Coupling Size	Shipping Weight lb. (kg)
			Standard Sprag			C/T Sprag							
			Outer Race	Inner <sup>†</sup> Race	Drive Speed	Outer Race	Inner Race	Sprag Lift-off	Drive Speed				
420	183 (248)	3.5 (2.6)	850	2,800	6,200	5,000	2,800	1,300	1,100	FSO-400	AR20	20 (9)	
530	575 (774)	11.0 (8.2)	800	2,500	5,000	4,000	2,500	1,200	1,000	FSO-500	AR30	42 (19)	
640	1500 (2033)	29.0 (21.6)	750	2,200	3,750	3,600	2,200	1,200	1,000	FSO-600	AR40	91 (41)	

\* For clutch dimensions and bore/keyseat sizes, see pages 15 and 17.

† Labyrinth grease seals permit higher inner race overrunning speeds, see pages 14 and 16.

### FW

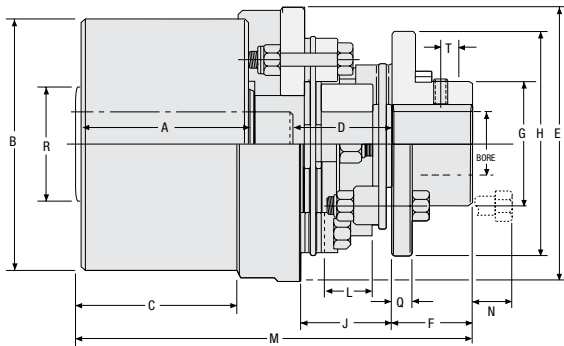

Coupling sizes 403 through 712 have PCE sprags. C/T sprags are available for all sizes.

### FWW

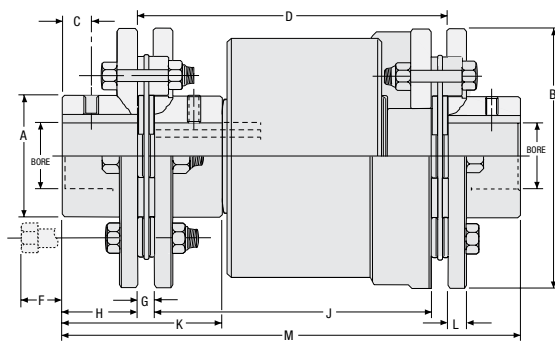

Coupling sizes 420 through 640 have PCE sprags. C/T sprags are available for all sizes.

### FW

#### Dimensions inches (mm)

Size	A	B	C	D	E	F	G	H	J	L	M	N	Q	R	T
403	2.75 (69.85)	3.500/3.498 (88.90/88.85)	2.53 (64.26)	2.39/1.72 (60.71/43.69)	4.00 (101.60)	1.00 (25.40)	1.80 (45.72)	3.19 (81.03)	1.72 (43.69)	1.18 (29.97)	6.167 (156.64)	0.62 (15.75)	0.30 (7.62)	1.187 (30.15)	.375 (9.53)
406	2.75 (69.85)	3.500/3.498 (88.90/88.85)	2.53 (64.26)	2.67/1.74 (67.82/44.20)	4.08 (103.63)	1.38 (35.05)	2.40 (60.96)	4.08 (103.63)	1.83 (46.48)	1.14 (29)	6.740 (171.20)	0.57 (14.5)	0.35 (8.89)	1.187 (30.15)	.500 (12.70)
504	3.50 (88.90)	4.250/4.248 (107.95/107.90)	3.25 (82.55)	2.64/1.74 (67.06/44.20)	4.75 (120.65)	1.38 (35.05)	2.40 (60.96)	4.08 (103.63)	1.83 (46.48)	1.14 (29)	7.460 (189.48)	0.57 (14.5)	0.35 (8.89)	1.770 (45.0)	.500 (12.70)
508	3.50 (88.90)	4.250/4.248 (107.95/107.90)	3.25 (82.55)	3.70/2.48 (93.98/62.99)	5.63 (143.00)	1.88 (47.75)	3.30 (83.82)	5.63 (ø143)	2.77 (70.28)	1.87 (47.72)	9.085 (230.76)	.55 (14)	0.55 (13.97)	1.770 (45.0)	.687 (17.45)
607	3.75 (95.25)	5.375/5.373 (136.53/136.47)	3.50 (88.90)	3.30/2.63 (83.82/66.80)	5.86 (148.84)	1.62 (41.15)	3.14 (79.76)	ø4.84 (ø123)	2.46 (62.44)	1.61 (41)	8.47 (215.05)	.34 (8.5)	0.35 (8.89)	2.750 (69.85)	.625 (15.88)
610	3.75 (95.25)	5.375/5.373 (136.53/136.47)	3.50 (88.90)	5.35/4.17 (135.89/105.92)	7.79 (197.87)	2.50 (63.50)	5.21 (132.45)	7.99 (ø203)	3.99 (101.4)	2.49 (63.2)	11.34 (288.11)	1.12 (28.5)	0.55 (13.97)	2.750 (69.85)	1.20 (30.48)
708	5.00 (127.00)	7.125/7.123 (180.98/180.92)	4.94 (125.48)	4.60/3.58 (116.84/90.93)	7.12 (180.85)	2.25 (57.15)	3.17 (113.00)	6.65 (ø169)	3.62 (92)	2.44 (62)	11.91 (302.48)	0.63 (16)	0.45 (11.43)	4.000 (101.60)	.875 (22.23)
712	5.00 (127.00)	7.125/7.123 (180.98/180.92)	4.94 (125.48)	4.69/3.26 (119.13/82.80)	7.79 (197.87)	3.00 (76.20)	5.21 (132.45)	7.99 (ø203)	3.99 (101.4)	2.49 (63.2)	13.55 (344.19)	0.63 (16)	0.55 (13.97)	4.000 (101.60)	1.203 (30.56)
752	6.00 (152.40)	8.750/8.748 (222.25/222.20)	5.94 (150.88)	4.69/3.26 (119.13/82.80)	8.75 (222.25)	3.00 (76.20)	5.21 (132.45)	ø7.99 (ø203)	3.99 (101.4)	2.49 (63.2)	14.10 (358.19)	0.63 (16)	0.55 (13.97)	4.250 (107.95)	1.203 (30.56)
812	6.00 (152.40)	10.000/9.998 (254.00/253.95)	5.94 (150.88)	4.69/3.26 (119.13/82.80)	10.00 (254.00)	3.00 (76.20)	5.21 (132.45)	ø7.99 (ø203)	3.99 (101.4)	2.49 (63.2)	14.29 (362.99)	0.63 (16)	.55 (13.97)	5.500 (139.70)	1.203 (30.56)

### FWW

#### Dimensions inches (mm)

Size	A	B	C	D	F	G	H	J	K	L	M
420	2.40 (60.96)	4.08 (103.63)	0.50 (12.70)	5.56 (141.23)	0.57 (14.5)	0.34 (8.74)	1.38 (35.05)	4.87 (123.75)	2.98 (75.69)	0.35 (8.89)	8.32 (211.33)
530	3.30 (83.82)	5.63 (143)	0.69 (17.53)	7.55 (191.77)	1.14 (29)	0.45 (11.43)	1.88 (47.75)	6.65 (168.91)	4.23 (107.44)	0.55 (13.97)	11.31 (287.27)
640	4.45 (112.99)	6.65 (169)	0.87 (22.10)	8.98 (228.09)	1.00 (25.40)	0.57 (14.53)	2.50 (63.5)	7.84 (199.03)	5.60 (142.24)	0.35 (8.89)	13.98 (355.09)

# Clutch Couplings

## FW/FWW

Coupling standard bore sizes and keyseats inches (mm)

Coupling Size	Bore Size	Keyseat	Bore Range	
			Min.	Max.
AP10W	500	1/8 × 1/16 (3.18 × 1.59)	.375 (9.53)	1.625 (41.28)
	750	3/16 × 3/32 (4.76 × 2.36)		
	1.000 1.250	1/4 × 1/8 (6.35 × 3.18)		
AP20W	1.000 1.125 1.250	1/4 × 1/8 (6.35 × 3.18)	3.75 (9.53)	2.125 (53.98)
	1.375	5/16 × 5/32 (7.93 × 3.96)		
	1.500 1.525	3/8 × 3/16 (9.52 × 4.75)		
AP25W	1.375	5/16 × 5/32 (7.93 × 3.96)	.500 (12.70)	2.375 (60.33)
	1.625	3/8 × 3/16 (9.52 × 4.75)		
	1.875 2.000	1/2 × 1/4 (12.70 × 6.35)		
AP30W	1.875 2.000 2.125	1/2 × 1/4 (12.70 × 6.35)	.625 (15.88)	2.875 (73.03)
	2.375	5/8 × 5/16 (15.87 × 7.93)		
	2.125	1/2 × 1/4 (12.70 × 6.35)		
AP35W	2.375 2.625	5/8 × 5/16 (15.87 × 7.93)	.625 (15.88)	3.750 (95.25)
	2.875	3/4 × 3/8 (19.05 × 9.52)		
	2.375	5/8 × 5/16 (15.87 × 7.93)		
AP40W	2.375	5/8 × 5/16 (15.87 × 7.93)	750 (19.05)	3.75 (95.25)
	2.875	3/4 × 3/8 (19.05 × 9.52)		
AP45W	Any Coupling Bore is Standard Between Minimum and Maximum Shown with Standard Tolerances		1.375 (34.93)	4.625 (117.48)

Coupling standard bore sizes and keyseats inches (mm)

Coupling Size	Bore Size	Keyseat	Bore Range	
			Min.	Max.
AR20	1.000 1.125	1/4 × 1/8 (6.35 × 3.18)	.375 (9.53)	2.125 (53.90)
	1.250 1.375	5/16 × 5/32 (7.93 × 3.96)		
	1.500 1.625	3/8 × 3/16 (9.52 × 4.75)		
AR30	1.875 2.000	1/2 × 1/4 (12.70 × 6.35)	.625 (15.88)	2.875 (73.03)
	2.125 2.375	5/8 × 5/16 (15.87 × 7.93)		
	2.375	5/8 × 5/16 (15.87 × 7.93)		
AR40	2.375	5/8 × 5/16 (15.87 × 7.93)	750 (19.05)	3.75 (95.25)
	2.875	3/4 × 3/8 (19.05 × 9.52)		



### Selection Procedure

- Calculate the drive torque to be transmitted by the clutch coupling:  

$$\text{Drive Torque (lbs.-ft.)} = \frac{5250 \times \text{HP}}{\text{RPM}}$$
- Select proper Service Factor from the table below.
- Determine Design Torque:  

$$\text{Design Torque (lbs.-ft.)} = \text{Service Factor} \times \text{Drive Torque}.$$
- Determine shaft size and bore requirements of clutch and coupling. Check key and shaft stress before making final selection since this may determine maximum allowable drive torque capacity. Metric bore and keyseats available on request.
- Determine overrunning speed and the type of clutch coupling required (FW or FWW). Standard FW and FWW Clutch Couplings (Form-Flex coupling combined with a FSO clutch) are designed for high speed inner race overrunning and intermediate speed outer race overrunning.
  - FW C/T or FWW C/T models may be used in applications where the drive RPM is lower than the listed C/T maximum drive RPM and the outer race overrunning RPM is higher than the listed lift-off RPM.
  - FW C/T or FWW C/T models may not be used in applications where the drive RPM is higher than the listed maximum drive RPM.
- Determine the direction of rotation required. These units are not symmetrical, rotational direction must be specified.
- Select a clutch coupling from the catalog based on Design Torque, Bore Size and overrunning speed to meet the application requirements.
- Check the maximum drive speed rating of the clutch coupling selected. If the application speed requirement is greater than the maximum drive speed rating consult Formsprag.
- Check space limitations to allow axial space for assembly and disassembly of clutch coupling.
- Do not exceed angular or parallel alignment shown on page 120.
- Check lubrication requirements (refer to page 134). Grease is not recommended where ambient temperatures are below +20°F.

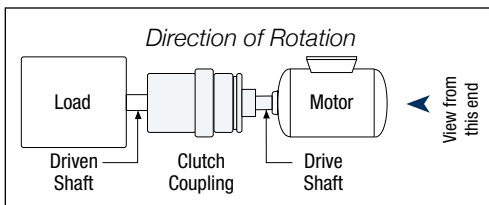

### Service Factors

#### Formsprag Overrunning Clutch

Couplings are suitable for many different power transmission applications. Please refer to this table for proper service factor for your application.

Typical Prime movers are listed below, types of loads across the top, and your service factor opposite the typical prime movers.

		Driven Equipment Load Classifications			
		Light Steady Loads Starting torque is equal to or slightly greater than running torque.	Moderate Loads High starting torque or above average running torque.	Medium Loads Starting torque is approximately double running torque.	Heavy-Duty Loads High starting torque, shock loading, light torque reversals during drive.
		Centrifugal pumps, uniformly loaded conveyors, light-duty fans and blowers, liquid mixers and agitators, centrifugal compressors, lobe and vane type blowers, gear pumps, textile machinery, woodworking machinery.	Hot oil pumps, heavy-duty centrifugal pumps, cooling towers, slurry agitators, boiler feed pumps, hoists, conveyors.	Dredge pumps, dynamometer drives, light-duty hammermills, lineshafts, paper-converting machinery, rotary kilns, rotary or screw-type pumps for high viscosity fluids.	Mine ventilating fans, reciprocating pumps or compressors, papermaking machinery, heavy-duty hammermills, ore crushers, pulverizing mills.
Prime Mover	Steam, gas or air turbine	1.00	1.50	1.50	2.50
	AC electric motor	1.25	1.50	1.50	2.50
	DC electric motor with DOL start AC electric motor	1.25	1.50	1.75	3.00
	Gasoline, natural gas, propane or other spark ignition engine	1.75	1.75	Consult Formsprag	Consult Formsprag
	Diesel	Consult Formsprag	Consult Formsprag	Consult Formsprag	Consult Formsprag

DOL = Direct on Line

# Clutch Couplings

## FW/FWW

### Installation and Alignment Procedure

#### Mounting and Preliminary Alignment

Reasonable care in initial assembly and aligning will permit clutch-coupling to operate to full capacity, compensate for misalignment, and provide long service life.

1. Inspect shafts and bores and make sure they are free from burrs. Check for the proper fit of the keys to the shafts and bores.
2. Position the coupling hub so that the shaft end is flush with the machined face of the flange. Coupling hub shrink fits are not necessary with Form-Flex couplings. If the hub is bored for an interference fit, the hubs should be heated in oil at 200–250°F and then quickly positioned on the shaft. Do not spot heat as it may cause distortion.
3. Check clutch for proper rotation by overrunning (freewheeling) clutch by hand. Mount clutch and key on shaft. Mount so that clutch will stay in place in service. Use shoulders, snap rings, set collars, or locking keys. Fit the clutch/ adapter assembly so that A) the machined face of the adapter is flush with the proper shaft end or B) the dimension as specified on the installation drawing between the shaft end and the machined face of the adapter is maintained.
4. Move the equipment to be connected into position. Set the gap between hub and adapter flanges to the "Adapter to Coupling Flange Dimension" within  $\pm .010$ ". For special clutch couplings, refer to the installation drawing for the proper dimension.

#### Angular Alignment

5. After preliminary alignment, secure a dial indicator to the adapter flange and indicate face of the coupling hub as shown in figures 1 and 2.
6. Rotate the adapter flange to which the indicator is attached to find minimum indicator reading. Set the indicator for zero reading.
7. Again, rotate the coupling half (with indicator attached) 360° to check misalignment.

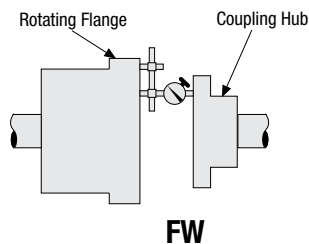

Figure 1. Angular alignment.

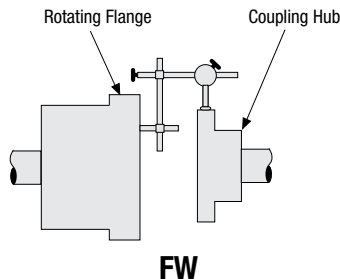

Figure 3. Parallel alignment.

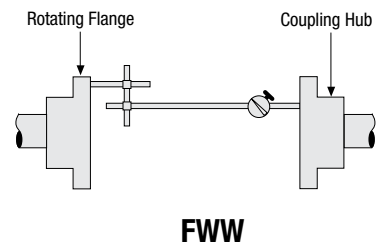

Figure 2. Angular alignment.

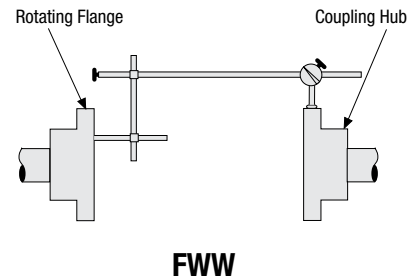

Figure 4. Parallel alignment.

Coupling Model No.	T.I.R.	
	Angular	Parallel
403	.028	.006
406	.036	.006
420	.036	.012
504	.036	.006
508	.048	.008
530	.048	.029
607	.042	.009
610	.068	.015
640	.058	.030
708	.050	.012
712	.068	.015
728	.052	.004
732	.066	.005
745	.068	.039
752	.068	.015
754	.080	.017
755	.080	.048
812	.068	.015

\* Bolts should be lubricated with grease before assembling.

8. Adjust position of connected equipment until indicator reading is within the allowable variation shown in the table at right.

#### Parallel Alignment

9. Reposition the indicator as shown in figure 3 and/or figure 4 and check for parallel alignment. Adjust the height of connected equipment to attain minimum misalignment. The allowable parallel misalignment is indicated in the table above.
10. Recheck angular alignment to make certain the values in the table have not been exceeded.

#### Coupling Assembly

11. Assemble the clutch coupling.
 

**Note:** The curved face of the washers must be placed adjacent to the flexible element pack. Do not drive or force bolts into position. The thick washers nest in the large clearance holes in the flanges.
12. Torque tighten all nuts to the value shown below. Check torque on nuts after several hours of actual running. Use "Loctite" on bolts which fasten into tapped holes.

For further information see Installation and Maintenance Bulletin WRN 2332, P-222-28.

### FW

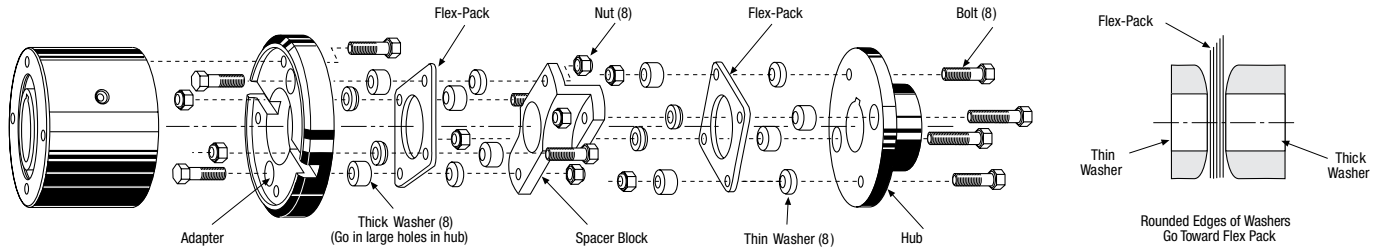

### FWW

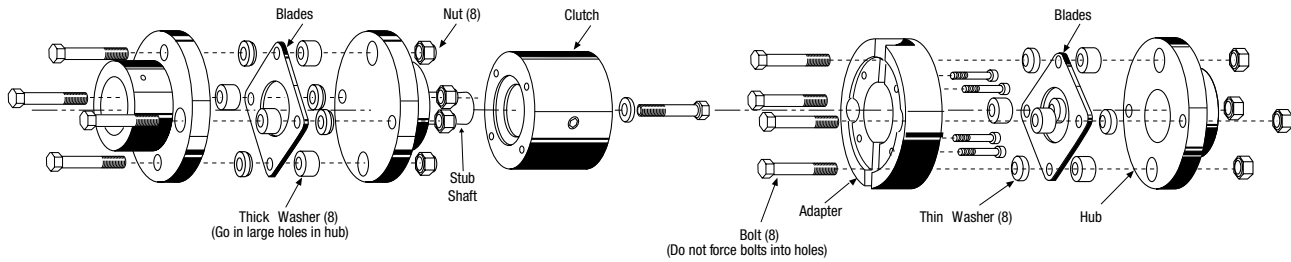

### Torque Values (mm)

Coupling Model No.	Tightening Torque lb.ft. (Nm.)*
403	8 (10.5)
406	19 (26)
420	19 (26)
504	19 (26)
508	66 (90)
530	66 (90)
607	37 (50)
610	236 (320)
640	110 (150)
708	110 (150)
712	236 (320)
728	58 (78.636)
732	115 (155.917)
745	115 (155.917)
752	236 (320)
754	465 (630)
755	465 (630)
812	236 (320)

\* Bolts should be lubricated with grease before assembling.

### How to Order

#### Available Modifications

Special designs are available. Contact Formsprag Engineering.

- **Custom length spacers** to accommodate greater distance between shafts.
- **Dynamic balancing** for high speed applications
- **Spined bore** for spined shafts.
- **Taperlock and Q.D. bushings** for the coupling hub.
- **Tapered bore coupling hubs** for mill motors.
- **Holding brake** to provide overrun drag when required for turbine or motor dual drive systems.

#### Example

When the assembly number is known, please specify:

Series \_\_\_\_\_ **FW** \_\_\_\_\_  
 Model No. \_\_\_\_\_ **504** \_\_\_\_\_  
 Assembly No. \_\_\_\_\_ **- 36** \_\_\_\_\_  
 Direction of Rotation (see page 115) \_\_\_\_\_ **RH** \_\_\_\_\_

When the assembly number is not known, please specify:

#### Item

#### Example

Series and Model No.....FW-752  
 Clutch Bore (Driven or Driving) ..... Clutch 2.50" Driven Shaft  
 Keyseat Size (If other than listed on page 15)  
 Coupling Bore (Driven or Driving) ..... Coupling 2.75" Driving Shaft  
 Keyseat Size (If other than listed on page 113)  
 Direction of Rotation (see page 115) .....Rotation RH  
 Lubricant, Oil/GR (Grease).....GR  
 Labyrinth seal optional..... L

# Accessories

## Axial Restraint Set Collars

### Axial Restraint

Formsprag requires that all clutches and holdbacks be axially restrained when mounted. Our recommended bore to shaft fits are loose to facilitate installation and removal, therefore, axial restraint must be provided by set collars, shoulders, restraining keys, retaining snap rings, retainer plates, or some other axial restraint device approved by Formsprag.

Holdback axial restraint is required to prevent the reaction end of the torque arm from imposing biasing loads on the bearings. Holdbacks installed without axial restraint can shift on the shaft, causing bearing loads which can significantly reduce bearing B-10 life.

For customers wishing to have a tolerance gap between the axial restraining device and the holdback inner race, a maximum gap of 1/8" per side is recommended.

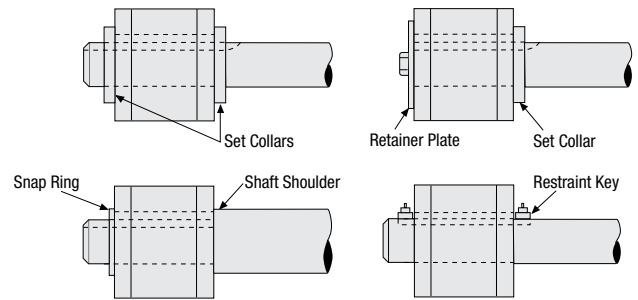

### Set Collars

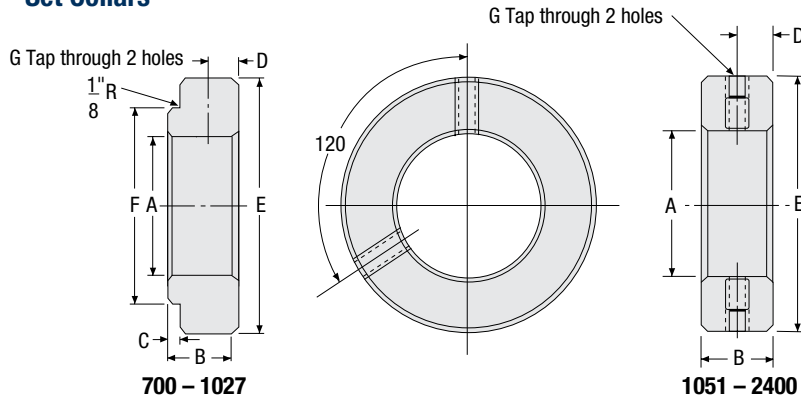

Shaft Length Required to Mount LLH with Two Set Collars

Model	Required Shaft Length	
	in.	mm
700	8.67	220.22
750	9.64	244.86
800	9.91	251.49
900	10.28	261.11
1027	11.03	280.16
1051	12.13	308.10
1250	13.25	336.55
1300	13.25	336.55
1375	14.50	368.30
2000	14.13	358.90
2400	14.88	377.95
3500	22.00	558.80
5000	22.00	558.80

### Dimensions inches (mm)

Size	Part No.	A Bore	B	C	D	E	F	G Bore	Screw
700	CL32136-1	1.938 to 2.938 (49.23 to 74.63)	1.625 (41.28)	.625 (15.88)	.500 (12.70)	4.000 (101.60)	3.500 (88.90)	.500-20	SC2206-N
750	CL32136-2	2.438 to 3.438 (61.93 to 87.33)	1.565 (39.70)	.563 (14.30)	.500 (12.70)	4.500 (114.30)	4.000 (101.60)	.500-20	SC2206-N
800	CL32136-3	2.938 to 4.438 (74.63 to 112.73)	1.688 (42.88)	.688 (17.48)	.500 (12.70)	5.500 (139.70)	5.000 (127.00)	.500-20	SC2206-N
900	CL32136-4	3.938 to 5.438 (100.03 to 138.13)	1.688 (42.88)	.688 (17.48)	.500 (12.70)	6.500 (165.10)	6.000 (152.40)	.500-20	SC2206-N
1027	CL32136-5	4.938 to 7.000 (125.43 to 177.80)	1.938 (49.23)	.688 (17.48)	.625 (15.88)	8.000 (203.20)	7.625 (193.68)	.500-20	SC2206-N
1051	CL32136-6	4.938 to 7.000 (125.43 to 177.80)	1.250 (31.75)	—	.625 (15.88)	8.000 (203.20)	—	.500-20	SC2206-N
1250	CL32136-8	6.750 to 9.000 (171.45 to 228.60)	1.500 (38.10)	—	.750 (19.05)	10.000 (254.00)	—	.625-18	SC2608-N
1300	CL32136-9	7.938 to 10.000 (201.64 to 254.00)	1.500 (38.10)	—	.750 (19.05)	11.250 (285.75)	—	.625-18	SC2608-N
1375	CL32136-15	8.938 to 11.000 (227.03 to 279.40)	1.750 (44.45)	—	.875 (22.23)	13.000 (330.20)	—	.750-10	SC2711-N
2000	CL32136-12	11.000 to 13.250 (279.40 to 336.55)	1.750 (44.45)	—	.875 (22.23)	15.500 (393.70)	—	.750-10	SC2711-N
2400	CL32136-13	13.250 to 15.500 (336.55 to 393.70)	2.000 (50.80)	—	1.000 (25.40)	19.563 (496.90)	—	.750-10	SC2711-N
3500									Built-in Set Collar
5000									Built-in Set Collar

## Axial Restraint Set Collars

### Axial Restraint Keys Introduction

Restraint keys are a cost effective method of providing axial restraint for clutches and holdbacks. The restraint key is longer than the clutch through bore length or clutch width. The single block key will prevent axial movement in only one direction and must be used with some other means to prevent movement in the other direction such as a set collar or a step in the shaft.

The double block key will prevent axial movement of the clutch in either direction. All restraint keys must be secured in the shaft keyseat. This can usually be accomplished by cutting the keyseat with an end mill without breaking out at the end of the shaft.

#### Single Block

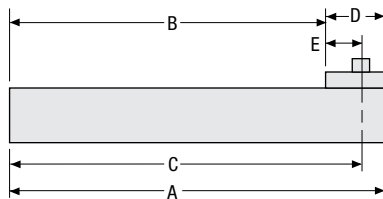

LLH-700 thru LLH-1027

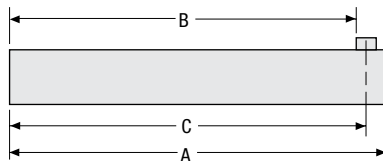

LLH-1051 thru LLH-5000

#### Double Block

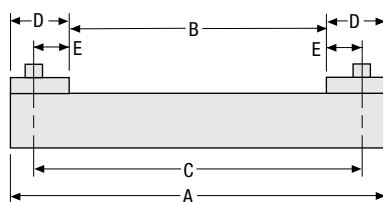

LLH-700 thru LLH-1027

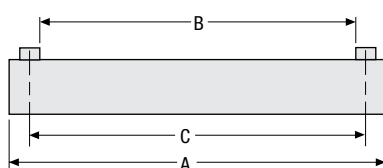

LLH-1051 thru LLH-5000

#### Single Block Style inches (mm)

Size	A	B	C	D	E	Screw Series
700	6.312 (160.32)	5.062 (128.57)	6.000 (152.40)	1.250 (31.75)	.937 (23.80)	SC1000
750	7.500 (190.50)	6.062 (153.97)	7.062 (179.37)	1.437 (36.50)	1.000 (25.40)	SC1000
800	7.625 (193.68)	6.062 (153.97)	7.187 (182.44)	1.562 (39.67)	1.125 (28.58)	SC1300
900	8.062 (204.77)	6.437 (163.50)	7.625 (193.68)	1.625 (41.28)	1.187 (30.15)	SC1500
1027	8.312 (211.12)	6.687 (169.85)	7.875 (200.03)	1.625 (41.28)	1.187 (30.15)	SC1500
1051	10.625 (269.88)	9.687 (246.05)	9.968 (253.19)	—	—	SC1700
1250	11.187 (284.15)	10.312 (261.92)	10.593 (269.06)	—	—	SC1700
1300	11.187 (284.15)	10.312 (261.92)	10.593 (269.06)	—	—	SC1700
1375	12.187 (309.55)	11.062 (280.97)	11.437 (290.50)	—	—	SC2100
2000	11.625 (295.28)	10.687 (271.45)	11.062 (280.97)	—	—	SC2100
2400	11.875 (301.63)	10.937 (277.80)	11.687 (296.85)	—	—	SC2100

#### Double Block Style inches (mm)

Size	A	B	C	D	E	Screw Series
700	7.625 (193.68)	5.125 (130.18)	7.000 (177.80)	1.250 (31.75)	.938 (23.83)	SC1000
750	9.000 (228.60)	6.125 (155.58)	8.125 (206.38)	1.438 (36.53)	1.000 (25.40)	SC1000
800	9.250 (234.95)	6.125 (155.58)	8.375 (212.73)	1.563 (39.70)	1.125 (28.58)	SC1300
900	9.750 (247.65)	6.500 (165.10)	8.875 (225.43)	1.625 (41.28)	1.188 (30.18)	SC1500
1027	10.000 (254.00)	6.750 (171.45)	9.125 (231.78)	1.625 (41.28)	1.188 (30.18)	SC1500
1051	11.625 (295.28)	9.750 (247.65)	10.313 (261.95)	—	—	SC1700
1250	12.062 (306.37)	10.375 (263.53)	10.938 (277.83)	—	—	SC1700
1300	12.062 (306.37)	10.375 (263.53)	10.938 (277.83)	—	—	SC1700
1375	13.375 (339.73)	11.125 (282.58)	11.875 (301.63)	—	—	SC2100
2000	12.625 (320.68)	10.750 (273.05)	11.500 (292.10)	—	—	SC2100
2400	13.000 (330.20)	11.000 (279.40)	11.750 (298.45)	—	—	SC2100

3500 to 5000 as required

Note: Restraint keys must be secured in shaft keyseat.

# Accessories

## Stub Shaft Adapters

For Clutch Sizes 400 through 1027 Mount Gears, Pulleys, and Similar Attachments



Stub shaft adapters are available to fit clutches from size 400 through 1027. They are secured to the clutch by fastening to the tapped holes at the end face of the outer race. The stub shaft adapters may be used to mount gears, pulleys or similar attachments when the item to be mounted is too small to mount on the O.D. of the clutch, and to mount couplings when the customer desires to use a coupling other than the Formsprag-Formflex clutch coupling assembly.

Hardened bolts are supplied by Formsprag at no additional charge with purchased adapters.

### Selection

Size	Adapter No.	Kit No.
400	A-4	AC30156
500	A-5	AC30157
600	A-6	AC30158
700	A-7	AC30159-4
750	A-7.5	AC30161-5
800	A-8	AC30160-6
900	A-9	AC30162-4
1027	A-10	AC30163-A

Consult Formsprag for other stub shaft adapter sizes.

### Dimensions inches (mm)

Model No.	A	B	C	D
400	3.500/3.501 (88.90/88.85)	.751/1.750 (19.07/19.05)	1.50 (38.10)	5.09 (129.36)
500	4.250/4.251 (107.95/107.90)	1.251/1.250 (31.77/31.75)	1.75 (44.45)	6.19 (157.15)
600	5.375/5.376 (136.52/136.47)	1.751/1.750 (44.47/44.45)	2.00 (50.80)	6.75 (171.45)
700	7.125/7.126 (180.97/180.92)	2.752/2.750 (69.90/69.85)	2.50 (63.50)	8.44 (214.30)
750	8.750/8.751 (222.25/222.20)	3.252/3.250 (82.60/82.55)	3.00 (76.20)	10.50 (266.70)
800	10.000/10.001 (254.00/253.95)	4.252/4.250 (108.00/107.95)	3.75 (95.25)	11.13 (282.57)
900	12.000/12.001 (304.80/304.72)	5.252/5.250 (133.40/133.35)	4.50 (114.30)	12.25 (311.15)
1027	15.000/15.002 (381.00/380.92)	6.252/6.250 (158.80/158.75)	5.50 (139.70)	13.56 (344.42)

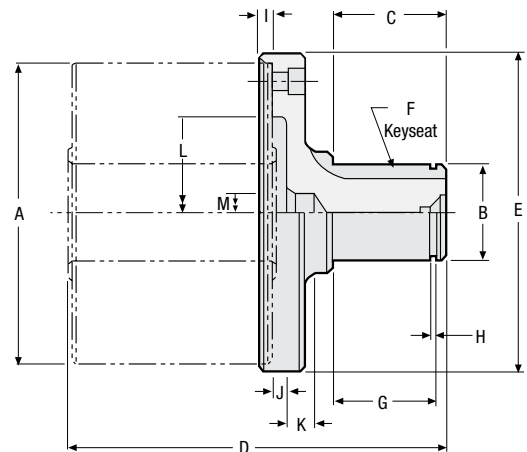

Detail drawings sufficient to manufacture stub shaft adapters are available on request for those who would prefer to manufacture their own.

Size	E	F	G	H	I	J	K	L	M	Weight lb. (kg)
400	3.88 (98.42)	.250 x .13 (6.35 x 3.18)	1.347/1.351 (34.21/34.31)	.033/.043 (.84/1.09)	0.250 (6.35)	0.188 (4.76)	0.438 (11.11)	1.875 (47.63)	0.563 (14.29)	1.6 (.73)
500	4.63 (117.47)	.312 x .16 (7.92 x 3.96)	1.579/1.584 (40.11/40.23)	.045/.055 (1.14/1.40)	0.250 (6.35)	0.250 (6.35)	0.500 (12.70)	2.625 (66.68)	0.625 (15.88)	3.2 (1.45)
600	5.75 (146.05)	.375 x .19 (9.52 x 4.75)	1.835/1.840 (46.61/46.99)	.055/.065 (1.40/1.65)	0.250 (6.35)	0.250 (6.35)	0.500 (12.70)	3.500 (88.90)	0.625 (15.88)	5.8 (2.63)
700	7.63 (193.67)	.625 x .31 (15.87 x 7.92)	2.335/2.340 (59.31/59.44)	.103/.113 (2.62/2.87)	0.250 (6.35)	0.250 (6.35)	0.500 (12.70)	5.000 (127.00)	0.625 (15.88)	12.6 (5.72)
750	9.50 (241.30)	.750 x .38 (19.05 x 9.52)	2.804/2.809 (71.22/71.35)	.103/.113 (2.62/2.87)	0.375 (9.53)	0.250 (6.35)	0.625 (15.88)	5.500 (139.70)	1.000 (25.40)	23.8 (10.79)
800	10.75 (273.05)	1.000 x .50 (25.40 x 12.70)	3.566/3.571 (90.57/90.70)	.120/.130 (3.05/3.30)	0.320 (8.13)	0.375 (9.53)	0.750 (19.05)	7.500 (190.50)	1.500 (38.10)	40.5 (18.37)
900	12.75 (323.85)	1.250 x .63 (31.75 x 15.87)	4.316/4.321 (109.63/109.75)	.139/.149 (3.53/3.78)	0.375 (9.53)	0.313 (7.94)	0.870 (22.10)	7.750 (196.85)	1.250 (31.75)	62.8 (28.49)
1027	15.75 (400.05)	1.250 x .63 (31.75 x 15.87)	5.140/5.145 (130.56/130.68)	.094/.104 (2.34/2.64)	0.375 (9.53)	0.310 (7.87)	0.875 (22.23)	10.000 (254.00)	1.250 (31.75)	103.4 (46.90)

## FSO, HPI, FRB OSHA Cover Kits



FSO, HPI, FRB OSHA cover kits are designed for shaft end mounted FSO, FRB, HPI or FHB clutches and available from Formsprag from size 400 through 1027. These cover kits provide not only the stationary cover enclosure required by OSHA, but provide additional protection for the clutch from abrasive environments as well.

The OSHA cover kit includes the cover and required fasteners.

**Note:** OSHA requires that a stationary guard must enclose clutches with rotating projecting parts and operating seven (7) feet or less above the floor.

### FSO, HPI, FRB

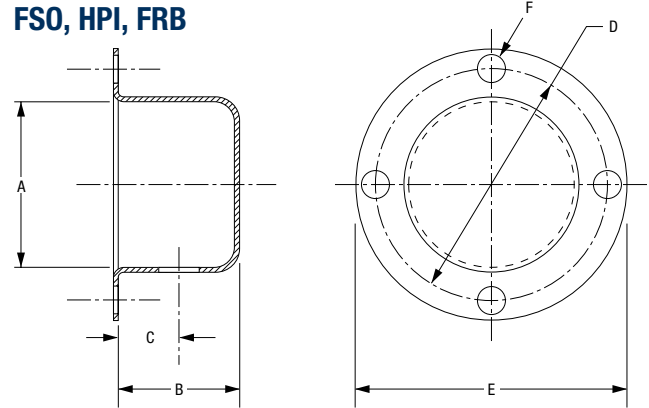

### FHB

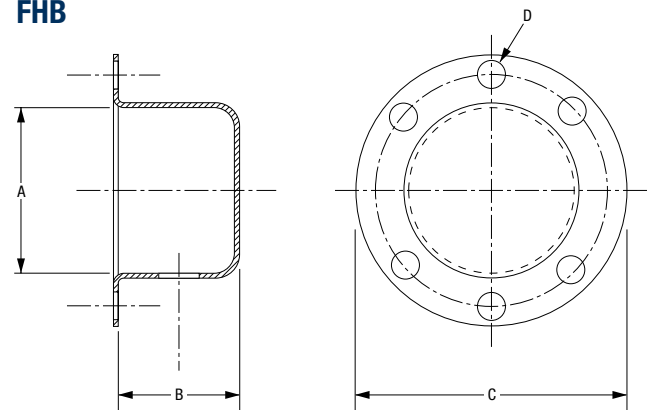

### FSO, HPI, FRB Cover & Dimensions inches (mm)

Size	Kit No.	A	B	C	D	E	F	F dia.
400	AC33594	2.06 (58.32)	1.50 (38.1)	0.75 (19.05)	2.88 (73.15)	3.38 (85.85)	4 @ 90°	0.34 (8.64)
500	AC33595	2.75 (69.85)	1.50 (38.1)	0.75 (19.05)	3.63 (92.20)	4.13 (104.90)	4 @ 90°	0.34 (8.64)
550	AC33713-1	2.25 (57.1)	1.50 (38.1)	0.75 (19.05)	4.25 (107.9)	4.75 (120.6)	6 @ 60°	0.34 (8.64)
600	AC33596	3.88 (98.55)	1.50 (38.1)	0.75 (19.05)	4.75 (120.65)	5.25 (133.35)	6 @ 60°	0.34 (8.64)
650	AC33714-1	3.25 (82.5)	1.50 (38.1)	1.00 (25.4)	5.75 (146)	6.50 (165.1)	8 @ 45°	0.40 (10.2)
700	AC33597	5.25 (133.35)	1.50 (38.1)	0.75 (19.05)	6.25 (158.75)	7.00 (177.80)	4 @ 90°	0.44 (11.18)
750	AC33600	5.88 (149)	2.00 (50.8)	1.00 (25.4)	7.00 (177.80)	8.00 (203.20)	4 @ 90°	0.56 (14.22)
800	AC33598	7.50 (190.5)	2.00 (50.8)	1.00 (25.4)	8.94 (227.08)	9.88 (250.95)	4 @ 90°	0.56 (14.22)
900	AC33599	8.56 (217.4)	2.00 (50.8)	1.00 (25.4)	9.75 (247.65)	11.00 (279.40)	6 @ 60°	0.69 (17.53)
1027	AC33601	10.23 (259.84)	3.00 (76.2)	1.50 (38.1)	11.75 (298.45)	13.50 (342.90)	4 @ 90°	0.75 (19.05)

### FHB Cover & Dimensions inches (mm)

Size	Kit No.	A	B	C	D*	
					No. of Holes	Dia.
10	CL70139	2.8 (69.9)	1.5 (38.1)	4.8 (120.7)	6 @ 60°	4.3 (109.2)
20	CL70140	3.9 (98.6)	1.5 (38.1)	5.3 (133.4)	6 @ 60°	4.8 (120.7)
60	CL70141	5.9 (149.4)	2.0 (50.8)	8.0 (203.2)	4 @ 90°	7.0 (177.8)

\* These covers can be used on other Formsprag clutches so there may be additional mounting holes, not required for the FHB Backstops.

# Accessories

## FSO Torque Arm

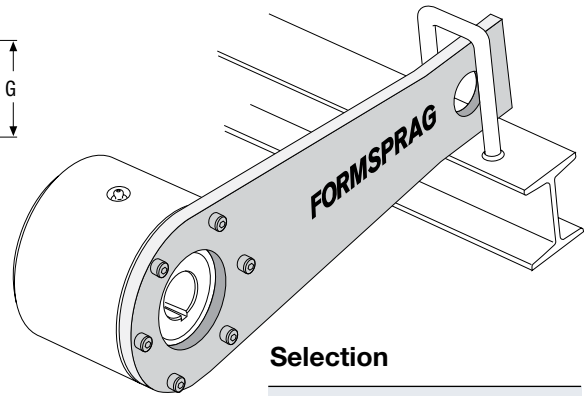
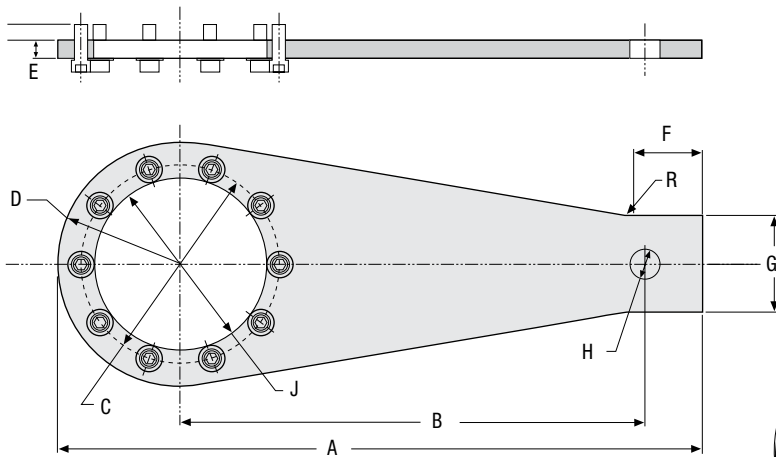

FSO Torque Arms are used to help facilitate the installation of the clutch when used as a backstop. The FSO Torque Arms are available to fit clutches from size 300 through 1027. These arms are designed to work with Clutch Models FSO, HPI, and HSB.

The torque arm must be secured to the clutch and must not be rigidly fastened at the reaction point. Rotation of the clutch must be restricted at the reaction point by either a pin or angle iron. Torque arm reaction point clearance is required on all sides of the arm to prevent binding, which could cause uneven loading of the clutch bearing, resulting in reduced clutch life.

### Selection

Size	Kit No.
300	TA300
400	TA400
500	TA500
550	TA550
600	TA600
650	TA650
700	TA700
750	TA750
800	TA800
900	TA900
1027	TA1027

### Dimensions inches (mm)

Size	A	B	C	D	E	F	G	H	J	No. of Bolts
300	9.63 (244.6)	7.13 (181.1)	2.62 (66.5)	1.50 (38.1)	0.38 (9.6)	1.50 (38.1)	1.50 (38.1)	0.75 (19)	1.25 (31.8)	4
400	9.63 (244.6)	7.13 (181.1)	2.87 (72.8)	1.75 (44.4)	0.38 (9.6)	1.50 (38.1)	1.50 (38.1)	0.75 (19)	1.25 (31.8)	4
500	13.00 (330.2)	9.63 (244.6)	3.62 (91.9)	2.13 (54.1)	0.38 (9.6)	2.25 (57.1)	2.25 (57.1)	1.00 (25.4)	1.80 (45.7)	4
550	10.13 (257.3)	7 (177.8)	4.25 (107.9)	2.5 (63.5)	0.38 (9.6)	1.37 (34.9)	2.25 (57.1)	0.78 (19.8)	2.43 (61.7)	12
600	16.00 (406.4)	11.88 (301.7)	4.75 (120.6)	2.68 (68)	0.38 (9.6)	2.50 (63.5)	2.50 (63.5)	1.00 (25.4)	2.81 (71.1)	6
650	13.63 (346)	9.5 (241)	5.75 (146)	3.25 (82.5)	0.38 (9.6)	1.75 (44.4)	3.0 (76.2)	0.78 (19.8)	3.4 (87.3)	16
700	21.00 (533.4)	15.75 (400)	6.25 (158.7)	3.56 (90.4)	0.50 (12.7)	3.00 (76.2)	3.00 (76.2)	1.25 (31.8)	4.25 (107.9)	8
750	22.31 (566.6)	15.25 (387.4)	7.00 (177.8)	4.38 (111.2)	0.50 (12.7)	2.91 (73.9)	4.38 (111.2)	1.25 (31.8)	5.50 (139.7)	8
800	26.41 (670.8)	18.63 (473.2)	8.94 (227)	5.00 (127)	0.50 (12.7)	3.56 (90.4)	4.75 (120.7)	1.25 (31.8)	6.75 (171.5)	8
900	31.72 (805.6)	22.88 (581.1)	9.75 (247.6)	6.00 (152.4)	0.88 (22.3)	3.38 (85.9)	4.75 (120.7)	1.50 (38.1)	8.50 (215.9)	10
1027	33.50 (850.9)	23.00 (584.2)	11.75 (298.5)	7.50 (190.5)	0.88 (22.3)	3.38 (85.9)	5.25 (133.3)	1.75 (44.5)	10.50 (266.7)	10



# Stieber Interchange Chart

## Cross-Reference Part Numbers

Stieber has two manufacturing facilities: one in Munich and a second in Heidelberg. These plants have produced identical clutches marketed under different part numbers as listed in the chart below. The models listed in bold are in current production and supersede the other model.

## Stieber Interchange Chart

Munich	Heidelberg	Munich	Heidelberg	Munich	Heidelberg
<b>AS</b>	NSS			CAB	<b>RS/BI, RBI</b>
<b>ASNU</b>	NFS			<b>CA</b>	—
AN	<b>NF</b>	—	ETK	CLA	<b>RIW, RIZ</b>
ANG/ANR	<b>NFR</b>	—	ETKG	CLAP	<b>RIWN, RINZ</b>
AG	<b>GFR</b>			F...	<b>RS/BF</b>
<b>AL(P)</b>				<b>CR</b>	—
AGP	<b>GFRN</b>			<b>CSK</b>	KK
<b>AL..G</b>	<b>EOC</b>			<b>CSK..P</b>	—
<b>ALB..M</b>	RS/RW			<b>CSK..RS</b>	—
<b>ALB..M</b>	UGF/UGR			CLV(P)	<b>RAZ, RANZ</b>
AV..04	<b>RS/BW</b>			—	<b>GFK</b>
<b>AV</b>	—				
<b>AK</b>	—				
<b>AA</b>	—				
<b>AR</b>	—				
<b>ALZ</b>	—				
<b>AVZ</b>	—				
<b>ASK</b>	—				
<b>AE</b>	—				
—	KI				

## Cross-Reference Part Numbers

Formsprag	Morse	Renold	Marland
FS-02	—	SA-02	—
FS-04	—	SA-04	—
FS-05	—	SA-05	—
FSR-3	PB-3A	SB-3	—
FSR-5	PB-5A	SB-5	—
FSR-6	PB-6A	SB-6	—
FSR-8	PB-8A	SB-8	—
FSR-10	PB-10A	SB-10	—
FSR-12	PB-12A	SB-12	—
FSR-14	PB-14A	SB-14	—
FSR-16	PB-16A	SB-16	—
FSO-300	MG-300A	—	—
FSO-400	MG-400A	*SO-400	RMS-14
FSO-500	MG-500A	*SO-500	RMS-21
FSO-550	—	—	RMS-26
FSO-600	MG-600A	*SO-600	RMS-32
FSO-650	—	—	RMS-40
FSO-700	MG-700A	*SO-700	RMS-47
FS-750	MG-750A	*SO-750	RMS-55
FS-800	MG-800A	*SO-800	RMS-72
FS-900	MG-900A	*SO-900	—
FS-1027	MG-1000A	*SO-1000	—
HPI-300	MI-300A	—	—
HPI-400	MI-400A	SX-400	RMS-14
HPI-500	MI-500A	SX-500	RMS-21
—	—	—	RMS-26
HPI-600	MI-600A	SX-600	RMS-32
—	—	—	RMS-40
HPI-700	MI-700A	SX-700	RMS-47
HPI-750	MI-750A	SX-750	RMS-55
HPI-800	MI-800A	SX-800	RMS-72
HPI-900	MI-900A	SX-900	—
HPI-1027	MI-1000A	SX-1000	—
FS-100	HT-10	—	—
FS-200	HT-20	—	—
FS-300	HT-30	—	—
FSO-300L†	MO-300A	—	—
FSO-400L†	MO-400A	—	—
FSO-500L†	MO-500A	—	—
FSO-600L†	MO-600A	—	—
FSO-700L†	MO-700A	—	—
FSO-750L†	MO-750A	—	—
FSO-800L†	MO-800A	—	—
FSO-900L†	MO-900A	—	—
FSO-1027L†	MO-1000A	—	—

\* Also available for end face GR lubrication

† FSO Series with labyrinth seal option

## Bore Sizes and Shaft Tolerances

### English (inches)

Bore and shaft tolerances listed below will give the recommended fit for each size clutch. If a press fit is necessary, never exceed .001" (.025mm) interference fit.

For all bore and shaft sizes not listed below use same tolerances and fits as next larger size.

Shaft and key length must be equal to the length of the inner race of the clutch for proper engagement. If the shaft to clutch bore engagement is less than 100% contact Formsprag Engineering.

### Sleeve Bearing Clutches

Series	Nominal Bore	Bore Diameter	Shaft Diameter
FS	.250	.250/.252	.250/.249
	.375	.375/.377	.3745/.374
	.500	.500/.502	.4995/.499
	.625	.625/.626	.6245/.6240
	.750	.750/.751	.7495/.749
FSR	.875	.875/.876	.8745/.874
	1.000	1.000/1.001	.9995/.999
	1.125	1.125/1.126	1.1245/1.1235
	1.250	1.250/1.251	1.2495/1.2485
	1.375	1.375/1.376	1.3745/1.3735
	1.500	1.500/1.501	1.4995/1.4985
	1.625	1.625/1.626	1.6245/1.6235
	1.750	1.750/1.751	1.7495/1.7485
	1.875	1.875/1.876	1.8745/1.8735
	2.000	2.000/2.001	1.9995/1.9985
	2.187	2.187/2.188	2.1865/2.1855

\* For LLH series, see page 82.

## Metric Key Assemblies

For all overrunning clutch inner races connected to shaft by a key, our standard bore tolerance is H7, with keyway to JS10.

We recommend a shaft tolerance of h6 or j6. For maximum indexing accuracy, adjusted keys should be machined to give no clearance.

(Metric keyseat dimensions listed on page 129.)

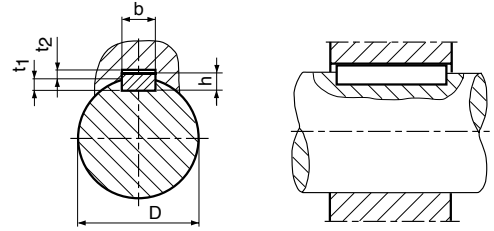

## Ball Bearing Clutches (except LLH Series)

Nominal Bore	Bore Diameter	Shaft Diameter
.500	.499/.500	.499/.498
.625	.624/.625	.624/.623
.750	.749/.750	.749/.748
.875	.874/.875	.874/.873
1.000	0.999/1.000	.999/.998
1.125	1.124/1.125	1.124/1.123
1.250	1.249/1.250	1.249/1.248
1.312	1.312/1.313	1.311/1.310
1.375	1.374/1.375	1.374/1.373
1.500	1.499/1.500	1.499/1.498
1.625	1.624/1.625	1.624/1.623
1.750	1.749/1.750	1.749/1.748
1.937	1.9365/1.9375	1.9365/1.9355
2.000	1.999/2.000	1.999/1.998
2.125	2.124/2.125	2.124/2.123
2.250	2.2485/2.2500	2.2485/2.2475
2.375	2.375/2.376	2.375/2.374
2.437	2.4360/2.4375	2.4360/2.4350
2.437	2.4365/2.4375	2.4365/2.4355
2.500	2.4985/2.5000	2.4985/2.4975
2.625	2.624/2.625	2.624/2.623
2.750	2.7485/2.7500	2.7485/2.7475
2.937	2.9360/2.9375	2.9360/2.9350
3.000	2.9985/3.0000	2.9985/2.9975
3.250	3.2485/3.2500	3.2485/3.2475
3.437	3.4360/3.4375	3.4360/3.4350
3.500	3.4985/3.5000	3.4985/3.4975
3.750	3.7485/3.7500	3.7485/3.7475
3.937	3.9360/3.9375	3.9360/3.9350
3.937	3.9355/3.9370	3.9355/3.9345
4.000	3.9985/4.0000	3.9985/3.9975
4.000	3.998/4.000	3.998/3.997
4.250	4.248/4.250	4.248/4.247
4.250	4.2485/4.2500	4.2485/4.2470
4.437	4.4355/4.4375	4.4355/4.4345
4.437	4.4360/4.4375	4.4360/4.4350
4.500	4.498/4.500	4.498/4.497
4.750	4.748/4.750	4.748/4.747
4.937	4.9355/4.9375	4.9355/4.9345
4.937	4.9360/4.9375	4.9360/4.9345
5.000	4.998/5.000	4.998/4.997
5.000	5.002/5.004	5.001/5.000
5.250	5.248/5.250	5.248/5.247
5.437	5.4355/5.4375	5.4355/5.4345
5.437	5.435/5.437	5.435/5.434
5.500	5.498/5.500	5.498/5.497
5.750	5.748/5.750	5.748/5.747
5.937	5.9355/5.9375	5.9355/5.9345
5.937	5.9360/5.9375	5.9360/5.9350
6.000	5.998/6.000	5.998/5.997
6.250	6.248/6.250	6.248/6.247
6.437	6.4355/6.4375	6.4355/6.4345
6.437	6.436/6.438	6.436/6.435
6.500	6.498/6.500	6.498/6.497
6.750	6.748/6.750	6.748/6.747
6.937	6.9355/6.9375	6.9355/6.9345

Nominal Bore	Bore Diameter	Shaft Diameter
7.000	7.000/6.998	6.997/6.998
7.500	7.504/7.506	7.503/7.502
7.750	7.754/7.756	7.753/7.752
8.000	8.004/8.006	8.003/8.002
8.250	8.254/8.256	8.253/8.252
8.500	8.504/8.506	8.503/8.502
8.750	8.754/8.756	8.753/8.752
9.000	9.004/9.006	9.003/9.002
9.250	9.254/9.256	9.253/9.252
9.500	9.504/9.506	9.503/9.502
9.750	9.754/9.756	9.753/9.752
10.000	10.004/10.006	10.003/10.002
10.500	10.504/10.506	10.503/10.502
11.000	11.004/11.006	11.003/11.002
11.500	11.504/11.506	11.503/11.502
12.000	12.004/12.006	12.003/12.001
12.250	12.254/12.256	12.253/12.251
12.500	12.504/12.506	12.503/12.501
13.000	13.004/13.006	13.003/13.001
13.250	13.254/13.256	13.253/13.251
13.500	13.504/13.506	13.503/13.501
13.750	13.754/13.756	13.753/13.751
14.000	14.004/14.006	14.003/14.001
14.250	14.254/14.256	14.253/14.251
14.500	14.504/14.506	14.503/14.501
14.750	14.754/14.756	14.753/14.751
15.000	15.004/15.006	15.003/15.001
15.250	15.254/15.256	15.253/15.251
15.500	15.504/15.506	15.503/15.501
15.750	15.754/15.756	15.753/15.751
16.000	16.004/16.007	16.003/16.001
16.250	16.254/16.257	16.253/16.251
16.500	16.504/16.507	16.503/16.501
16.750	16.754/16.757	16.753/16.751
17.000	17.004/17.007	17.003/17.001
17.250	17.254/17.257	17.253/17.251
17.500	17.504/17.507	17.503/17.501
17.750	17.754/17.757	17.753/17.751
18.000	18.004/18.007	18.003/18.001
18.250	18.254/18.257	18.253/18.251
18.500	18.504/18.507	18.503/18.501
18.750	18.754/18.757	18.753/18.751
19.000	19.004/19.007	19.003/19.001
20.000	20.004/20.007	20.003/20.001

- 1 Model 750 only
- 2 Model 900 only
- 3 Model 1027 only
- 4 Model 1051 only
- 5 FSO 600/2.00 tolerance 2.000/2.001
- 6 Model 800 only

Note: On Models 750 thru 5000, Formsprag may elect to supply a stepped key in the event of keyseat distortion during heat treat of inner race.



# Engineering Data

## Mounting Requirements

### Press fit assemblies

Shaft and bore tolerances are specified on the pages for each type where press fitting is appropriate.

As with standard bearings, suitable tooling must be used for press fitting such that no axial load is transmitted through the inner part of the clutch during assembly.

### Mounting Examples

#### Non-supported models

**FS-50**

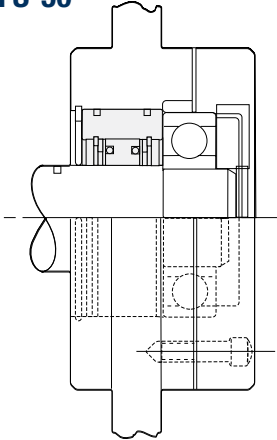

**AS**

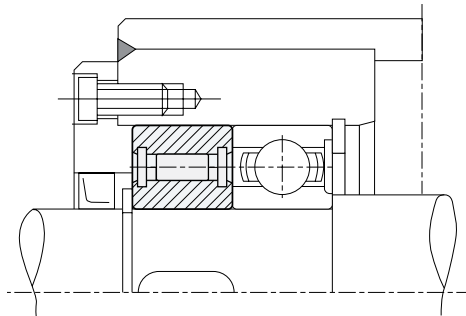

**RSCI**

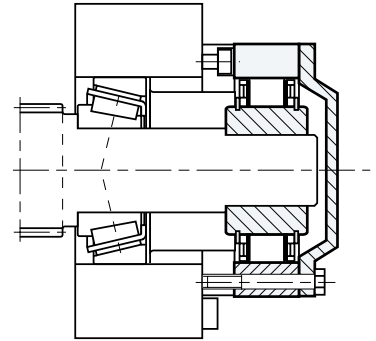

#### Bearing supported models

**RSBW**

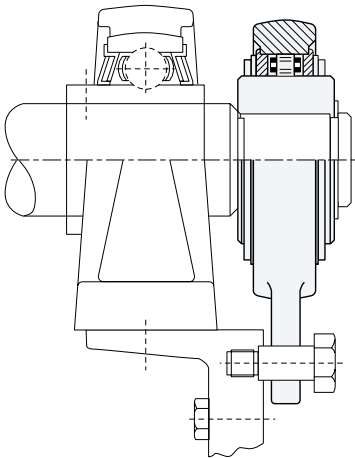

**FSR**

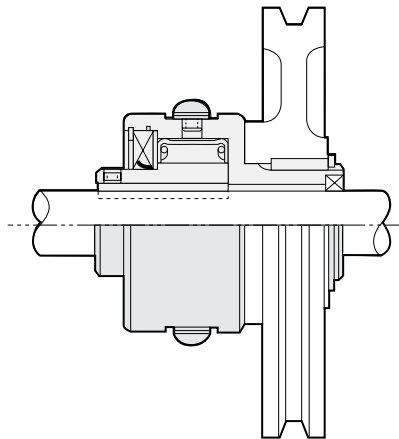

**GFR**

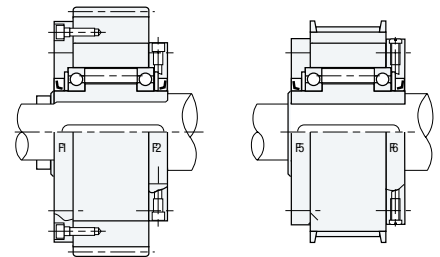

#### Combined bearing/clutch models

**CSK**

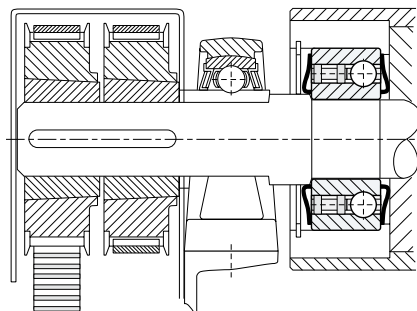

**RL**

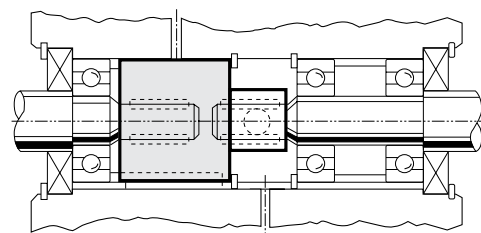

**FSO**

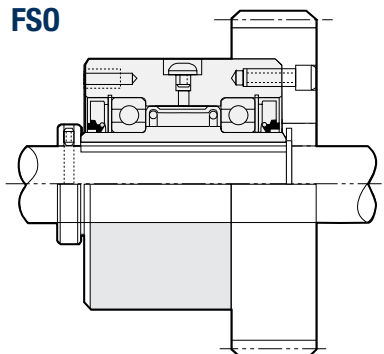

The list below of trouble shooting issues does not cover every scenario which might be experienced. It is only a quick guide. If the list does not cover your issue, always contact Formsprag Application Engineering for help.

Issue	Possible Correction
<b>Model FSO</b>	
Clutch has short operating life when used in backstopping applications.	Check torque arm to make sure it is not rigidly mounted, (Ref. Page 80).
Clutch slips and not holding the load.	Check lubricant type. Use only approved lubricants, many lubricants contain (EP) Extreme Pressure or anti-wear additives that reduce the coefficient of friction that the clutch design depends on for the transmission of torque (Ref. Page 134).
Clutch slips in cold weather.	Check lubricant operating range as the ambient temperature may be below the lower limit, (Ref. Page 134) contact Formsprag Engineering for low temperature approved lubricants.
Clutch slips after re-lubricating.	Check lubricant as not all lubricants are compatible, use only approved lubricants and flush completely when changing brands of lubricants (Ref. I & M Bulletins).
Clutch does not fit on the shaft with a slip fit.	Check shaft and bore size definitions (Ref. page 128) as shaft to bore fit must not be an interference fit.
Clutch is hard to install on Shaft.	Check key height to make sure it is not too tall. There must be clearance over the top of key. Normal design clearance is approximately 0.005 in. .
Clutch is running too hot	Oil clutches overrunning at maximum catalog speeds can reach 210° F at the outer race for the first 24 hours of operation before the lip seal wears in. The lip seal is the largest heat contributor to the clutch drag and internal heat generation. Maximum normal operating temperature at the outer race is 200°F.
Clutch leaks oil.	Determine location of oil leakage. If from around the lip seal area then the seal may need to be replaced. Check lip seal surface.
<b>Model FSO C/T</b>	
Clutch slips at high speeds.	Compare catalog maximum drive speed to application maximum drive speed. Designs with C/T Sprags can not drive beyond the Sprag lift-off speed.
<b>Model FSR</b>	
Clutch is leaking oil.	Oil can seep at the internal side of the inner race to the shaft area, check to see if a suitable sealant, such as RTV was applied around the bore and key seat at the end face of the inner race side, refer to service bulletin installation procedure.
Clutch is moving on shaft.	Set screws in the inner race are not tightened.
<b>Model HPI</b>	
Clutch is slipping.	Shaft and key tolerance should be a tight fit, at least line to line fits for indexing application. Alternately check for wrong type of lubricant containing EP additives, if any have been used contact Formsprag for rebuilding.
<b>Model LLH</b>	
Holdback operating life is short.	Check torque arm for loose mounting, or the wrong lubrication is being used with EP additives. Alternately check if clutch is not axially restrained, resulted in torque arm binding and reduced clutch bearing life, or oil sight gage not mounted correctly to show oil level.
Holdback is leaking oil.	Grease labyrinth seals require re-greasing quarterly or monthly under severe dusty conditions, if not job site contaminates can reach the internal oil lip seal area and compromise the lip seal or seal diameter, contact Formsprag for rebuilding.
<b>Model RL</b>	
Backstop does not operate smoothly. Experiences chatter.	Determine if there are over hauling torque load present, as RL clutches will not handle over hauling loads without special accommodation. If there are overhauling loads use the Model FL.

## Bearing Loads

Formsprag ball bearing clutches are able to carry both radial and thrust loads. Often it is necessary to check the radial loading of the bearings for an application where the clutch is subjected to radial loads imposed by drive chains, gears, sprockets or V- belts. The radial loads imposed by high tension, multi-V belts are particularly high.

The load that can be applied to a ball bearing clutch is dependent upon the bearings used in the clutch and the recommended bearing load rating as specified by the bearing manufacturer. Table 1 gives the Maximum Permissible Load (lbs.) for radial and thrust conditions for Formsprag ball bearing clutches sizes 300 through 1027. These loads are based upon a calculated L-10 bearing life of 10,000 hours (50,000 hrs. avg. bearing life). Higher loads are possible at lower speeds.

Condition #1 (A) is the Maximum Permissible Load (lbs.) for radial loads centered between the bearings.

Condition #2 (B) is the Maximum Permissible Load (lbs.) radially applied above the end face of the clutch.

Condition #3 (C) is the Maximum Permissible Load (lbs.) radially applied which can be offset or overhung from the end of the clutch.

**Example:** Determine the Maximum permissible load (C) that can be radially applied to a stub shaft adapter 10 inches from the end of a FSO-700 clutch.

Using the formula:

$$\text{Load (C)} = \frac{(A) (L)}{2 (d + D + L)}$$

$$\text{Load (C)} = \frac{2520 \times 3.060}{2 (10 + .925 + 3.060)}$$

$$\text{Load (C)} = 276 \text{ lbs.}$$

L-10 bearing lives for loads and speeds other than those listed in Table 1 for each clutch may be calculated by using the following formula:

$$(L-10)_0 = \left(\frac{A}{X_0}\right)^3 \times \left(\frac{N}{N_0}\right) \times 10,000$$

where: (L-10) is the new L-10 life in hrs.

$X_0$  is new load in lbs.

A is load from Table 1 in lbs.  
(note: B and C can be used in place of A for Conditions #2 and #3 as required)

N is overrunning (O/R) speed from Table 1.

$N_0$  is new O/R speed.

### Condition #1

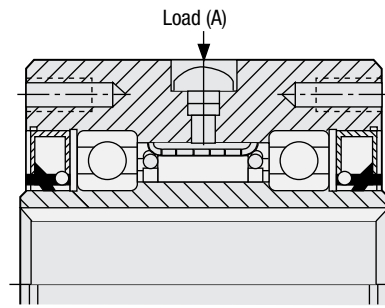

Condition #1 has force or Load (A) in center of clutch between the two ball bearings. (See Table 1.)

### Condition #2

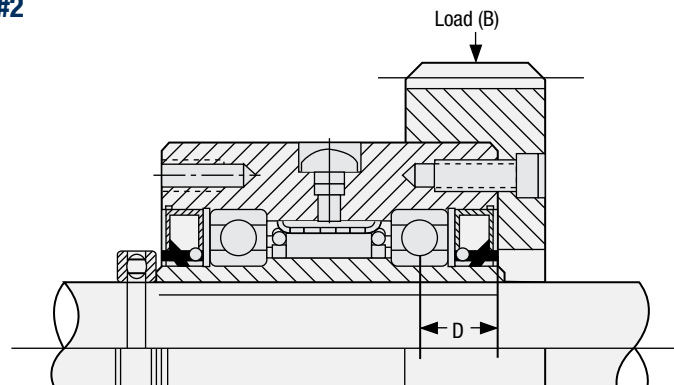

Condition #2 has force or Load (B) exerted on clutch bearings at end of clutch. Distance "D" is the distance from the centerline of the ball bearing nearest the load to end of clutch.

(See Table 1)

### Condition #3

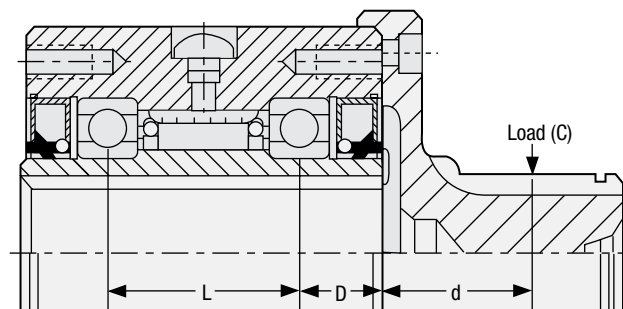

Condition #3 has force or load applied "d" distance from face of the clutch. (To be determined by individual application.) To calculate the Maximum Permissible Load (C) a distance "d" from the clutch face, use the following equation:

$$\text{Load (C)} = \frac{(A)(L)}{2 (d + D + L)}$$

(Refer to Table 1 for values of A, D and L)

**Table 1**

Clutch No.	Maximum Permissible Load		D in.	L in.	Thrust Cap. @ Max. O/R Speed lb.*	Max O/R Speed RPM
	Cond. #1 (A) lb.	Cond. #2 (B) lb.				
FSO-300	413	150	.516	1.381	413	3,600
FSO-400	480	160	.675	1.376	467	3,600
FSO-500	816	297	.745	1.990	820	3,000
FSO-600	879	304	.836	1.950	1,039	2,400
FSO-700	2,559	982	.925	3.060	2,810	2,000
FSO-750	1,656	612	1.247	3.550	2,158	1,800
FSO-800	2,412	891	1.251	3.542	3,237	1,500
FSO-900	3,183	1,191	1.257	3.740	4,046	1,350
FSO-1027	1,013	353	1.446	3.355	2,750	1,100
HPO-720	2,196	837	.925	2.96	1,098	3,000
HPO-750	1,795	663	1.247	3.53	897	2,600
HPO-800	2,273	840	1.251	3.55	1,136	2,100
HPO-900	2,712	1,014	1.257	3.73	1,356	1,850
HPO-1027	639	230	1.446	3.72	319	1,500

\* Always contact Formsprag Engineering for approval when applying axial loads to the clutch.

**Example:** Determine the maximum permissible load that can be radially applied between the bearings of a FSO-750 with an overrunning speed of 600 RPM that will result in a L-10 bearing life of 10,000 hours.

Since the load is applied between the bearings the value (A) for Condition #1 is used for this calculation. Also, because the bearing life is 10,000 hours, the new L-10 remains at 10,000 hrs.

Using the bearing life formula:

$$(L-10)_0 = \left(\frac{A}{X_0}\right)^3 \times \left(\frac{N}{N_0}\right) \times 10,000$$

Substituting values into the equation:

$$10,000 = \left(\frac{2,040}{X_0}\right)^3 \times \left(\frac{1,800}{600}\right) \times 10,000$$

$$X_0^3 = 2,040^3 \times \frac{1,800}{600} \times \frac{10,000}{10,000}$$

$$X_0 = \sqrt[3]{2,040^3 \times 3 \times 1}$$

$$X_0 = 2,942 \text{ lbs}$$

**Answer:** The new maximum permissible radial load that can be applied is 2,942 lbs.

The clutch thrust capacity at Max. O/R speed given in Table 1 is the **Maximum permissible load** applied in an axial direction to the end of the clutch. The clutch thrust capacity listed in Table 1 is without any radial load applied to the clutch.

For applications that have both thrust and radial loads consult Formsprag engineering.

Sleeve bearing clutches, models FS-02 through FSR-16, are equipped with oil-impregnated bronze bearings (Figure 1). The bearings are designed to provide proper support for radial loads imposed on the clutch hubs, however, they are not designed to accept axial loads.

Table 2 gives the radial load capacity for each sleeve bearing model. The bearing capacity shown is rated at the maximum overrunning (O/R) speed of the inner race for each clutch model.

Higher radial loads are possible at lower speeds. In such cases please consult Formsprag engineering.

**Table 2**

Clutch No.	Bore (Ref.)	Radial Load Capacity (lb.)	Max O/R Speed Inner Race RPM
FS-02	.250	12	3,450
FS-04	.375	15	2,800
FS-04	.500	15	2,800
FS-05	.625	30	1,800
FSR-3	.375	40	1,950
FSR-3	.500	40	1,950
FSR-5	.500	45	1,950
FSR-5	.625	45	1,950
FSR-6	.750	70	1,950
FSR-8	.875	110	1,650
FSR-8	1.000	110	1,650
FSR-10	1.125	130	1,250
FSR-10	1.250	130	1,250
FSR-12	1.375	190	1,150
FSR-12	1.500	190	1,150
FSR-14	1.625	250	950
FSR-14	1.750	250	950
FSR-16	1.875	260	950
FSR-16	2.000	260	950

**FS-02**

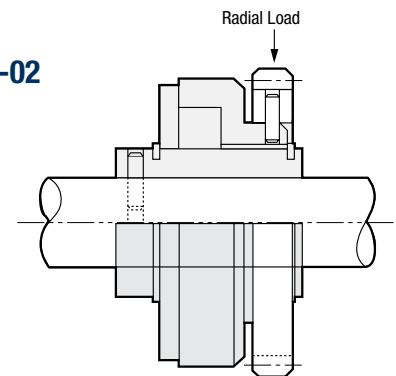

**FSR**

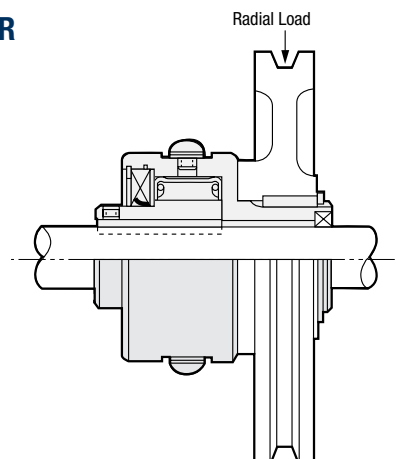

Figure 1

# Engineering Data

## Lubrication

Proper lubrication and lubricant maintenance are the most important single maintenance factors for long, effective, trouble-free clutch operation.

Many models are shipped from the factory prelubricated and ready to install. Some models require lubrication to be added prior to being put into service, and other designs rely on lubrication integral to the application, see the model data pages for details.

Formsprag has evaluated and approved a wide selection of oil and grease lubricants necessary to meet a wide range of customer application needs. If no lubricant is specified on the

order, the clutch will be supplied with the standard lubricant that is listed on the model data page. Not all lubricants are compatible, so before switching check with Formsprag Engineering. Grease lubrication is recommended for applications where: (1) conditions do not permit the type of maintenance required for oil lubricated clutches, (2) the clutch is exposed to severe dusty conditions, (3) the clutch is mounted on a vertical shaft.

The selection of the proper lubricant for each application should include the ambient temperature range; see the table below for a listing of approved lubricants. Contact Formsprag Engineering if you have any questions about lubrication.

## Recommended Lubricants

Overrunning and Backstopping Applications			
Temperature Range			
+20°F to +150°F (-7°C to +65°C) Maximum permissible ambient temperature	-20°F to +20°F (-23°C to -7°C) Ambient temperature	-40°F to +150°F (-40°C to +65°C) Maximum permissible ambient temperature	+20°F to +150°F (-7°C to +65°C) If below +20°F (-7°C) Consult Formsprag
Oil Lubricants			Grease Lubricants
Chevron GST Oil 68 Mobil DTE Heavy Medium Automatic Transmission Fluid (ATF)** Texaco Regal Oil R&O 68 Shell Turbo Oil 68 Amoco Industrial Oil 68 Exxon Teresstic Oil 68 Sunoco Sunvis 931 Mobil SHC-626	Mobil Gargoyle Arctic C Heavy Texaco Regal Oil R&O 46 Automatic Transmission Fluid (ATF)** Amoco Oil Industrial 46 Sunoco Sunvis 921 Mobil SHC-624 Royal Purple Synfilm GT (equivalent to ISO #32)	Mobil Jet Oil 2 Shell Aeroshell Turbine Oil 555 (MIL-PRF-23699) Shell Aeroshell Turbine Oil 500 (MIL-PRF-23699) Exxon Turbo Oil 2380 Exxon Turbo Oil 2389 Military Oils MIL-PRF-7808 or MIL-PRF-23699 * Mobil HFA (MIL-PRF-5606)	Fiske Bros. Lubriplate Low- Temp Fiske Bros. Aero Lubriplate Shell Aeroshell No. 7 Shell Aeroshell No. 22 Beacon 325
Indexing Applications			
At 150 strokes per minutes or less	At 150 strokes per minutes or less	-10°F or below (-23°C)	Not Applicable Consult Formsprag
Oil Lubricants			
Mobil DTE Light Oil Automatic Transmission Fluid (ATF)** Texaco Regal Oil R&O 32 Shell Turbo Oil 32 Amoco Industrial Oil 32 Exxon Teresstic Oil 32	Sunoco Sunvis 916 Exxon Zerice 46 Automatic Transmission Fluid (ATF)**	Consult Formsprag	

\* This lubricant is suitable for a low temperature and low speed application.

\*\* Dexron III or Type F automatic transmission fluid (ATF) only

**CAUTION:** Do not use EP additives type lubricants (extreme pressure characteristics) or those containing slippery additives, such as molybdenum disulfide graphite compounds.

## Bolt assemblies

In clutch designs torque is often transmitted through bolts. Experience has shown that it is a practical and reliable way since clutches transmit torque in only one direction.

For the metric clutch designs the Bolt Strength Standards (8.8, 10.9 and 12.9) and torque tightening values (Nm) are listed in the adjacent table.

## Metric Bolt Strength and Tightening Standards

Thread	8.8		10.9	
	Model	(Nm)	Model	(Nm)
M5	RSCI	(6)	GFR, AL, and RIZ	(8)
M6	RSCI	(10)	GFR, AL, and RIZ	(14)
M8	RSCI	(25)	GFR, AL, and RIZ	(34)
M10	RSCI	(48)	GFR, AL, and RIZ	(68)
M12	RSCI	(84)	GFR, AL, and RIZ	(118)
M16	RSCI	(206)	GFR, AL, and RIZ	(290)
M20	RSCI	(402)	GFR, AL, and RIZ	(550)
M24	RSCI	(696)	GFR, AL, and RIZ	(950)
M30	RSCI	(1420)	GFR, AL, and RIZ	(1900)



# Overrunning Clutches Application Data Form

For Application Assistance call 1-800-927-3262 or Fax (586) 758-5204

Date \_\_\_\_\_

Company name \_\_\_\_\_

Address \_\_\_\_\_

City \_\_\_\_\_ State \_\_\_\_\_ Zip \_\_\_\_\_

Name of contact \_\_\_\_\_ Title \_\_\_\_\_

Phone \_\_\_\_\_ Fax \_\_\_\_\_

## Type of equipment

\_\_\_\_\_  
\_\_\_\_\_

## Type of application

- Overrunning  Indexing  
 Backstop  Clutch Coupling

## Maximum torque at clutch

\_\_\_\_\_ pound-feet, or  
\_\_\_\_\_ HP at \_\_\_\_\_ RPM

## Power Source

- Electric motor  Diesel engine  
 Turbine  Air cylinder  
 Gasoline engine

## Load Application

- Smooth  Moderate  Shock

## Lubrication

- Runs in oil  Not accessible  
 Accessible for lubricating

## Type or specification of lubricant

\_\_\_\_\_

## For overrunning or backstop applications

Inner race speed during overrunning \_\_\_\_\_ RPM max.

Outer race speed during overrunning \_\_\_\_\_ RPM max.

If both members are rotating during overrunning, are they rotating in the

- Same direction  Opposite directions

## Time cycle of Formsprag clutch

Drive \_\_\_\_\_ minutes Rest \_\_\_\_\_ minutes

Over-run \_\_\_\_\_ minutes

## For indexing applications

Indexes per minute \_\_\_\_\_ max.

Degrees per index \_\_\_\_\_ max.

## Clutch operating time

\_\_\_\_\_ hours per day

Shaft diameter (give limits)

\_\_\_\_\_  
\_\_\_\_\_

## Size of keyseat in shaft

\_\_\_\_\_  
\_\_\_\_\_

## Environment

Temperature range \_\_\_\_\_ °F to \_\_\_\_\_ °F

Exposed location? \_\_\_\_\_

Radiation? \_\_\_\_\_

## For non-symmetrical clutches and clutch-couplings

a. Identify the end from which the clutch is viewed

\_\_\_\_\_

b. The (inner, outer) member (drives, over-runs) in the (clockwise, counter-clockwise) direction

## Anticipated quantity required

a. For this application

\_\_\_\_\_

b. Annually

\_\_\_\_\_

## Supply a sketch of your installation.

**Note:** A clutch is not a coupling. When necessary to couple two shafts, a coupling must be used with the clutch. Ambient temperature should not exceed approximately 150°F. It is requested that prints of installation be supplied if available.

Completed by \_\_\_\_\_

# Conversion Factors

## Conversion Factors

### Length

1 in.	= 25.4 mm = 0.0254 m	1 μm	= .00004 in.
1 ft.	= 304.8 mm = 0.3048 m	1 m	= 39.37 in.
		1 m	= 3.28 ft.

### Area

1 in. <sup>2</sup>	= 6.4516x10 <sup>-4</sup> m <sup>2</sup>	1 m <sup>2</sup>	= 1550 in. <sup>2</sup>
1 ft. <sup>2</sup>	= 9.29x10 <sup>-2</sup> m <sup>2</sup>	1 m <sup>2</sup>	= 10.764 ft. <sup>2</sup>

### Volume

1 in. <sup>3</sup>	= 1.639x10 <sup>-5</sup> m <sup>3</sup>	1 m <sup>3</sup>	= 61023 in. <sup>3</sup>
1 ft. <sup>3</sup>	= 2.832x10 <sup>-2</sup> m <sup>3</sup>	1 m <sup>3</sup>	= 35.315 ft. <sup>3</sup>
1 gal (US)	= 3.7854 l	1 l	= 0.2642 gal (US)

### Mass

1 lb. s <sup>2</sup> .ft. <sup>-1</sup>	= 14.6 kg	1 kg	= 6.85x10 <sup>-2</sup> lb. s <sup>2</sup> .ft. <sup>-1</sup>
---	-----------	------	---

### Force

1 lb.	= 445 g	1 kg	= 2.2 lb.
-------	---------	------	-----------

### Pressure

1 lb.in. <sup>-2</sup>	= 6.895x10 <sup>-3</sup> Nmm <sup>-2</sup>	1 Nmm <sup>-2</sup>	= 145 lb.in. <sup>-2</sup>
(pai)	= 6.895x10 <sup>3</sup> Nm <sup>-2</sup>	1 bar	= 14.2 lb.in. <sup>-2</sup>

### Torque

1 lb.in.	= 0.113 Nm	1 Nm	= 8.85 lb.in.
1 lb.ft.	= 1.36 Nm	1 Nm	= 0.738 lb.ft.

### Work

1 Btu	= 778 lb.ft.	1 kJ	= 0.948 Btu
1 Btu	= 1055 J = 1.055 kJ	1 kWh	= 3410 Btu
1 Btu	= 2.93x10 <sup>-4</sup> kWh		

### Power

1 HP	= 746 W = 0.746 kW	1 kW	= 1.34 HP
1 HP	= 1.014 CV	1 CV	= 0.986 HP

### Moment of Inertia

1 lb.ft. <sup>2</sup>	= 0.04214 kgm <sup>2</sup>	1 kgm <sup>2</sup>	= 23.73 lb.ft. <sup>2</sup>
1 lb.in. <sup>2</sup>	= 2.93x10 <sup>-4</sup> kgm <sup>2</sup>	1 kgm <sup>2</sup>	= 3417.17 lb.in. <sup>2</sup>
1 lb.ft. s <sup>2</sup>	= 1.3847 kgm <sup>2</sup>	1 kgm <sup>2</sup>	= 0.738 lb.ft. s <sup>2</sup>
1 lb.in. s <sup>2</sup>	= 0.1129 kgm <sup>2</sup>	1 kgm <sup>2</sup>	= 8.8507 lb. in. s <sup>2</sup>

### Mass/Volume

1 lb.ft. <sup>-3</sup>	= 16.018 kgm <sup>-3</sup>	1 kgm <sup>-3</sup>	= 6.24x10 <sup>-2</sup> lb.ft. <sup>-3</sup>
------------------------	----------------------------	---------------------	--

### Temperature

°F	= (1.8x°C) + 32	°C	= 5/9x(°F-32)
°F	= 1.8x(K-273) + 32		
K	= 5/9x (°F-32) + 273		

## Warranty

Formsprag LLC warrants that it will repair or replace (whichever in its sole discretion it deems advisable) any product it manufactured and sold which proves to be defective in material or workmanship within a period of one (1) year from date of original purchase for consumer, commercial or industrial use. This warranty extends only to the original purchaser and is not transferable or assignable without Formsprag LLC's prior consent.

This warranty covers normal use and does not cover damage or defect which results from alterations, accident, neglect, disassembly, or improper installation, operation, or maintenance.

Formsprag LLC's obligation under this warranty is limited to the repair or replacement of the defective product. In no event shall Formsprag LLC be liable for consequential, indirect or incidental damages of any kind incurred by reason of manufacture, sale or use of any defective product. Formsprag LLC neither assumes nor authorizes any other person to give any other warranty or to assume any other obligation or liability on its behalf.

## Performance Assurance

Rated torque and speeds of Formsprag Clutch products are provided in current catalogs to assist the buyer in selecting the proper Formsprag Clutch product. In addition, application assistance is offered by Formsprag Clutch for guidance to the buyer in selection of a catalog product and application of custom designed products. Since the actual performance characteristics of all Formsprag Clutch products in the buyer's application is the responsibility of the buyer, performance assurance is usually accomplished through manufacture of a prototype by Formsprag Clutch, and a test or qualification program on the part of the buyer.

## Rotating Equipment

Rotating equipment is potentially dangerous and should be properly guarded. The user should check for all applicable safety codes (in local area) and provide a suitable guard. Formsprag clutches and backstops have surfaces which wear with use over time and as a result will need to be replaced. The decision for time of replacement must be made by the operator of the equipment based upon the specific application and performance of the clutch or backstop.

## Catalog Changes

The contents of this catalog are subject to change without notice or obligation.

## Remanufactured Clutches...

### Look like New, Warrantied like New.

Formsprag Rebuild Service Department can refurbish your overrunning clutches. We take your worn, scaled, seized, scored, or rough running clutches and make them like new...for substantially less than the replacement cost.

As a major manufacturer of overrunning clutches, we have the people, facilities, and experience to rebuild and replace all components as needed. The same standards of excellence that exist in the manufacture of original equipment clutches are closely adhered to in the overhaul procedure of every rebuilt clutch.

### The difference is not just cosmetic.



The Rebuild Service Department will perform the following procedures to restore your overrunning clutches to original specifications with a new warranty:

All internal components—sprags, energized springs, retainer, bearings, seal and hardware are refurbished or replaced to new performance standards. The inner and outer races are ground to specifications noted below so that no wear patterns remain.

- Sprag Surface is hardened to 58-62 Rc
- Sprag Surface finish is 15-25 microinches
- Sprag Surface taper limit is 0.0002 inch per inch

#### Consider these advantages:

Price – A guaranteed savings of 30% (compared to list price for a new unit).

Speed – Clutches are received, inspected and rebuilt in the shortest possible time frame.

Warranty – 1 Year on labor and materials, same as new clutches

Emergency Breakdown Program – All products that are air freighted into the Formsprag Clutch plant are processed immediately and, in most cases, are able to be rebuilt within a 24-hour period.

We're also interested in helping you prevent problems and failures. We can recommend a preventive maintenance schedule for all your clutches.

Contact your representative or our Warren Plant for details on our cost-saving program.





# A variety of market and application-specific literature is available from Formsprag Clutch

Formsprag products are hard at work in a wide range of industrial applications including Aerospace & Defense, Mining, and Nuclear Power Generation. Visit the literature portal at [www.formsprag.com](http://www.formsprag.com) to download these market brochures and accompanying application sheets.

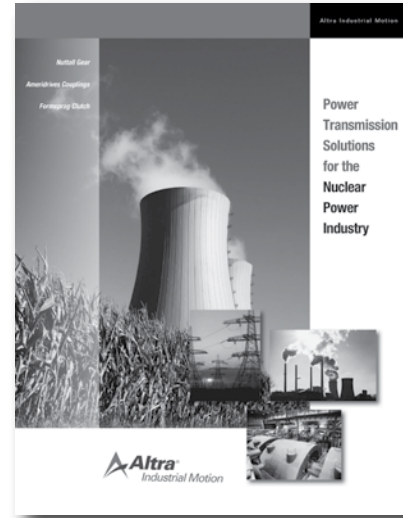

## Nuclear Power Market Brochure

P-1904-C

## Aerospace & Defense Market Brochure and Application Sheets

P-1717-C



## Mining Market Brochure and Application Sheets

P-1763-C





**Overrunning Clutches Application Guide**

P-1465-FC

A convenient Overrunning Clutches Application Guide and accompanying sheets for a range of additional applications are also available for download at [www.formsprag.com](http://www.formsprag.com).

P-1350-2-FC



P-1350-1-FC



P-1350-3-FC



P-1350-9-FC

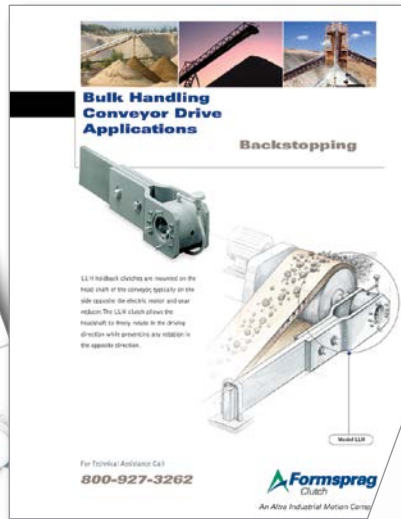

P-1350-13-FC



P-1350-6-FC

All Customer Service phone numbers shown in bold

<p><b>Belted Drives and Sheaves</b></p> <p><b>TB Wood's</b> <i>Belted Drives</i> Chambersburg, PA - USA <b>1-888-829-6637</b> – Press #5 <i>For application assistance:</i> <i>1-888-829-6637 – Press #7</i></p> <p><b>Couplings</b></p> <p><b>Ameridrives Couplings</b> <i>Mill Spindles, Ameriflex, Ameridisc</i> Erie, PA - USA <b>1-814-480-5000</b> <i>Gear Couplings</i> San Marcos, TX - USA <b>1-800-458-0887</b></p> <p><b>Ameridrives Power Transmission</b> <i>Universal Joints, Drive Shafts, Mill Gear Couplings</i> Green Bay, WI - USA <b>1-920-593-2444</b></p> <p><b>Bibby Turboflex</b> <i>Disc, Gear, Grid Couplings, Overload Clutches</i> Dewsbury, England <b>+44 (0) 1924 460801</b> Boksburg, South Africa <b>+27(0) 11 918 4270</b></p> <p><b>Guardian Couplings</b> <i>Engineered Flywheel Couplings, Engine Housings and Pump Mounts, Flexible Shaft Couplings</i> Michigan City, IN - USA <b>1-219-874-5248</b></p> <p><b>Huco Dynatork</b> <i>Precision Couplings and Air Motors</i> Hertford, England <b>+44 (0) 1992 501900</b> Chambersburg, PA - USA <b>1-888-829-6637</b></p>	<p><b>Couplings Cont.</b></p> <p><b>Lamiflex Couplings</b> <i>Flexible Couplings, Bearing Isolators, and Coupling Guards</i> Cotia, SP - Brasil <b>+55 (11) 4615-6300</b></p> <p><b>TB Wood's</b> <i>Elastomeric Couplings</i> Chambersburg, PA - USA <b>1-888-829-6637</b> – Press #5 <i>For application assistance:</i> <i>1-888-829-6637 – Press #7</i> <i>General Purpose Disc Couplings</i> San Marcos, TX - USA <b>1-888-449-9439</b></p> <p><b>Electromagnetic Clutches and Brakes</b></p> <p><b>Inertia Dynamics</b> <i>Spring Set Brakes; Power On and Wrap Spring Clutch/Brakes</i> New Hartford, CT - USA <b>1-800-800-6445</b></p> <p><b>Matrix International</b> <i>Electromagnetic Clutches and Brakes, Pressure Operated Clutches and Brakes</i> Brechin, Scotland <b>+44 (0) 1356 602000</b> New Hartford, CT - USA <b>1-800-825-6544</b></p> <p><b>Warner Electric</b> <i>Electromagnetic Clutches and Brakes</i> New Hartford, CT - USA <b>1-800-825-6544</b> <i>For application assistance:</i> <i>1-800-825-9050</i> Saint Barthélemy d'Anjou, France <b>+33 (0)2 41 21 24 24</b> <i>Precision Electric Coils and Electromagnetic Clutches and Brakes</i> Columbia City, IN - USA <b>1-260-244-6183</b></p>	<p><b>Engineered Bearing Assemblies</b></p> <p><b>Kilian Manufacturing</b> <i>Engineered Bearing Assemblies</i> Syracuse, NY - USA <b>1-315-432-0700</b></p> <p><b>Gearing</b></p> <p><b>Bauer Gear Motor</b> <i>Gearred Motors</i> Esslingen, Germany <b>+49 (711) 3518-0</b> Somerset, NJ - USA <b>1-732-469-8770</b></p> <p><b>Boston Gear</b> <i>Enclosed and Open Gearing, Electrical and Mechanical P.T. Components</i> Charlotte, NC - USA <b>1-800-825-6544</b> <i>For application assistance:</i> <i>1-800-816-5608</i></p> <p><b>Nuttall Gear and Delroyd Worm Gear</b> <i>Worm Gear and Helical Speed Reducers</i> Niagara Falls, NY - USA <b>1-716-298-4100</b></p> <p><b>Heavy Duty Clutches and Brakes</b></p> <p><b>Industrial Clutch</b> <i>Pneumatic and Oil Immersed Clutches and Brakes</i> Waukesha, WI - USA <b>1-262-547-3357</b></p> <p><b>Svendborg Brakes</b> <i>Industrial Brakes and Brake Systems</i> Vejrstrup, Denmark <b>+45 63 255 255</b></p> <p><b>Twiflex Limited</b> <i>Caliper Brakes and Thrusters</i> Wichita Falls, TX - USA <b>1-844-723-3483</b> Twickenham, England <b>+44 (0) 20 8894 1161</b></p>	<p><b>Heavy Duty Clutches and Brakes Cont.</b></p> <p><b>Wichita Clutch</b> <i>Pneumatic Clutches and Brakes</i> Wichita Falls, TX - USA <b>1-800-964-3262</b> Bedford, England <b>+44 (0) 1234 350311</b></p> <p><b>Linear Products</b></p> <p><b>Warner Linear</b> <i>Linear Actuators</i> Belvidere, IL - USA <b>1-800-825-6544</b> <i>For application assistance:</i> <i>1-800-825-9050</i> Saint Barthélemy d'Anjou, France <b>+33 (0)2 41 21 24 24</b></p> <p><b>Overrunning Clutches</b></p> <p><b>Formsprag Clutch</b> <i>Overrunning Clutches and Holdbacks</i> Warren, MI - USA <b>1-800-348-0881</b> – Press #1 <i>For application assistance:</i> <i>1-800-348-0881 – Press #2</i></p> <p><b>Marland Clutch</b> <i>Roller Ramp and Sprag Type Overrunning Clutches and Backstops</i> South Beloit, IL - USA <b>1-800-216-3515</b></p> <p><b>Stieber Clutch</b> <i>Overrunning Clutches and Holdbacks</i> Heidelberg, Germany <b>+49 (0) 6221-30470</b></p> <p><i>For information concerning our sales offices in Asia Pacific check our website <a href="http://www.altramotion.com.cn">www.altramotion.com.cn</a></i></p>
---	---	--	--



[www.formsprag.com](http://www.formsprag.com)

23601 Hoover Road  
Warren, MI 48089 - USA  
586-758-5000  
Fax: 586-758-5204